

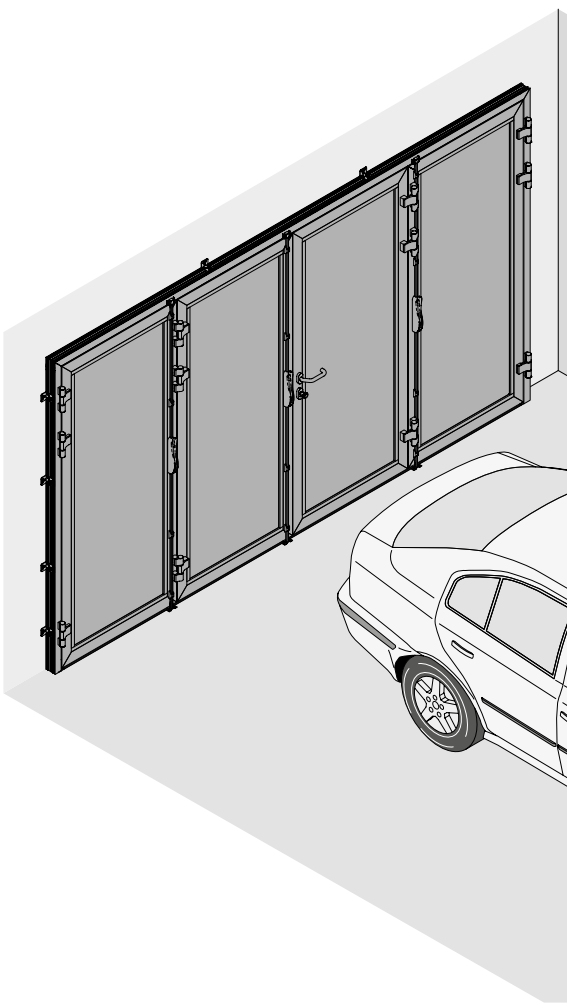

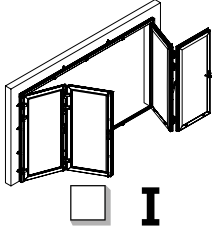
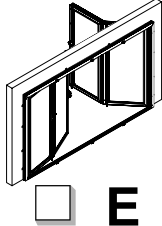

Notice de pose porte battante 4 vantaux

Einbauanleitung Drehtür 4-flügelig

Installation instructions for 4-leaf swing door

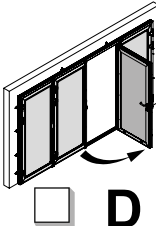
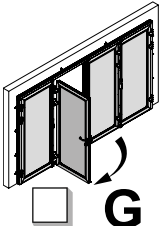

Ouverture <i>Öffnungsrichtung</i> Opening	Intérieure <i>Nach Innen</i> <i>To the inside</i>	Extérieure <i>Nach Außen</i> <i>To the outside</i>
	 I	 E
Pose <i>Montage Anschlag</i> Mounting stop	Tunnel <i>In der Öffnung</i> <i>Build in</i>	Applique <i>Hinter der Öffnung</i> <i>Build on</i>
	 T	 A
Tirant <i>Richtung Innen</i> <i>Pulling direction</i>	Droite <i>Rechts</i> <i>Right</i>	Gauche <i>Links</i> <i>Left</i>
	 D	 G
Configuration / Konfiguration / Configuration :		
<input type="checkbox"/> <input type="checkbox"/> <input type="checkbox"/> →  Pages / Seiten / Pages 2-3		

Option / Option / Variante	Oui / Ja / Yes	Non / Nein / No
Arrêt de porte à visser <i>Screw-on door stop</i> <i>Türfeststeller zum Anschrauben</i>	<input type="checkbox"/>	<input type="checkbox"/>
Arrêt de porte à sceller <i>Door stop to seal</i> <i>Türfeststeller zum Versiegeln</i>	<input type="checkbox"/>	<input type="checkbox"/>

IAD

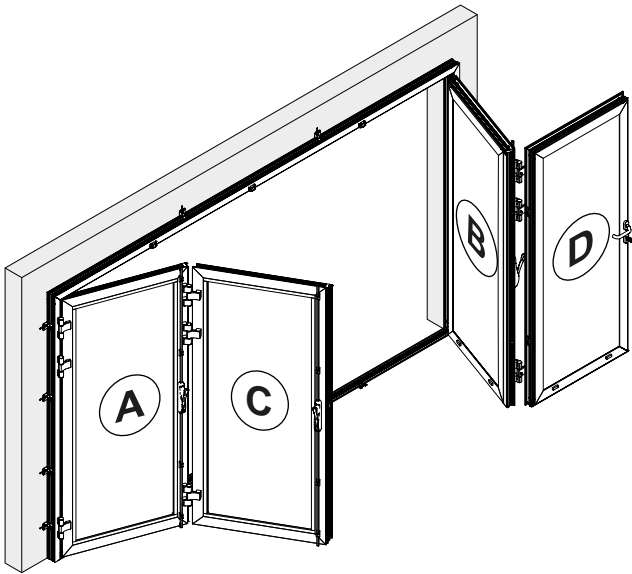

ITD

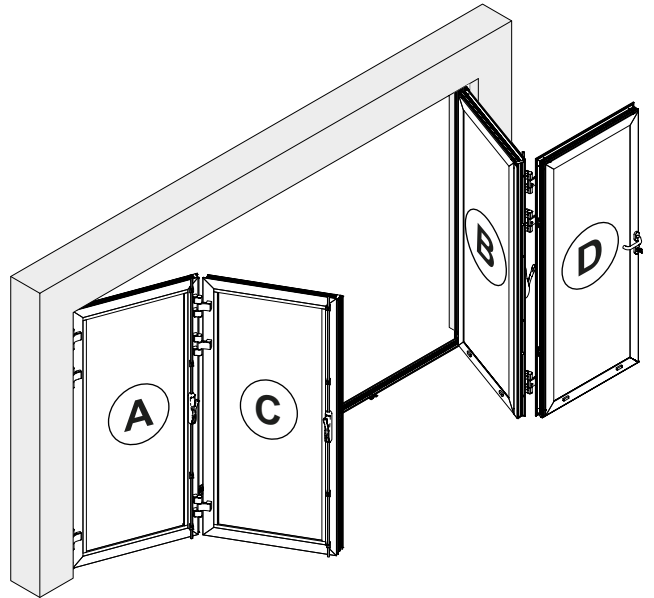

IAG

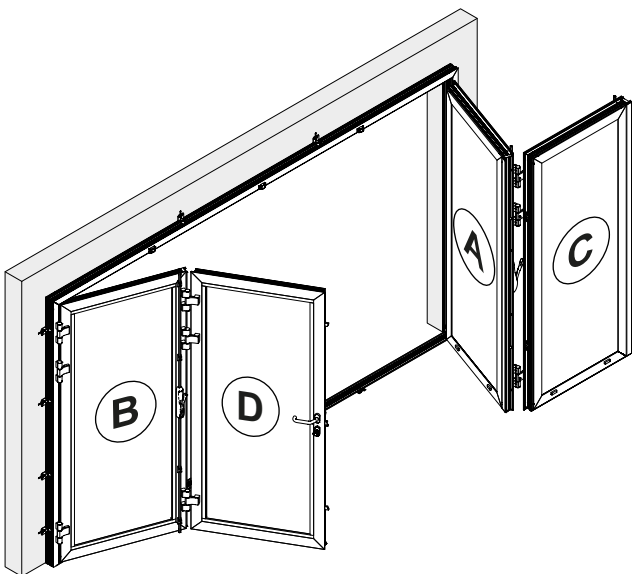

ITG

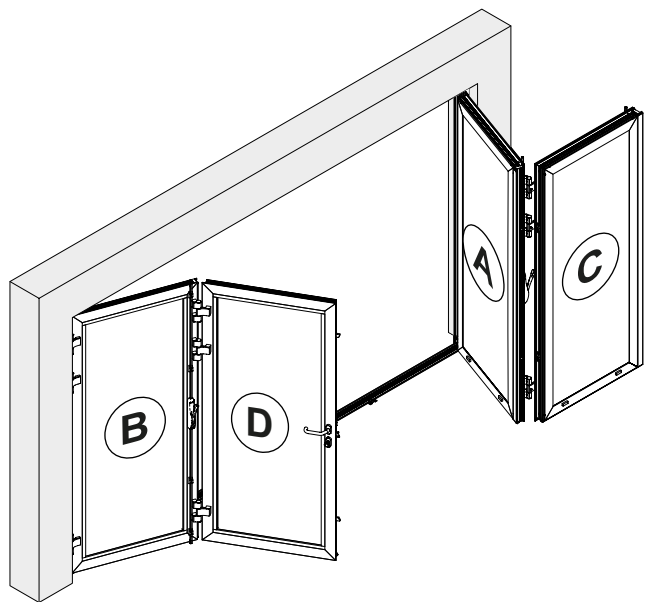

EAD

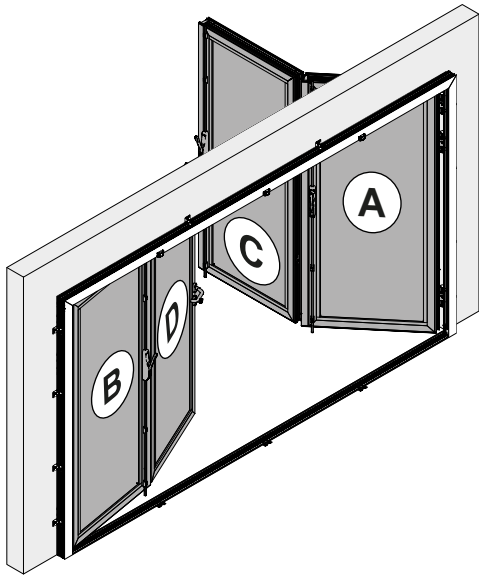

ETD

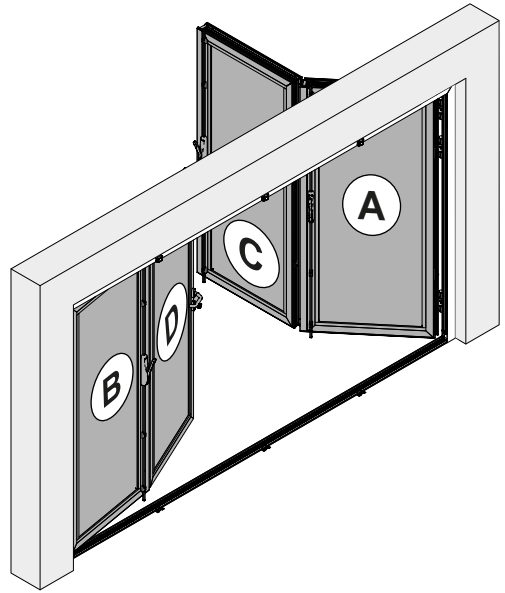



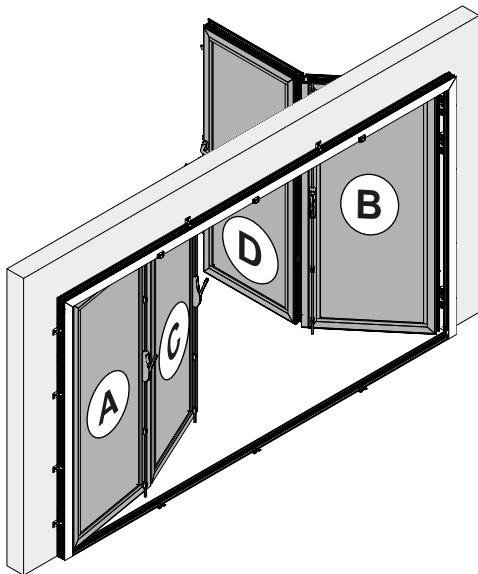



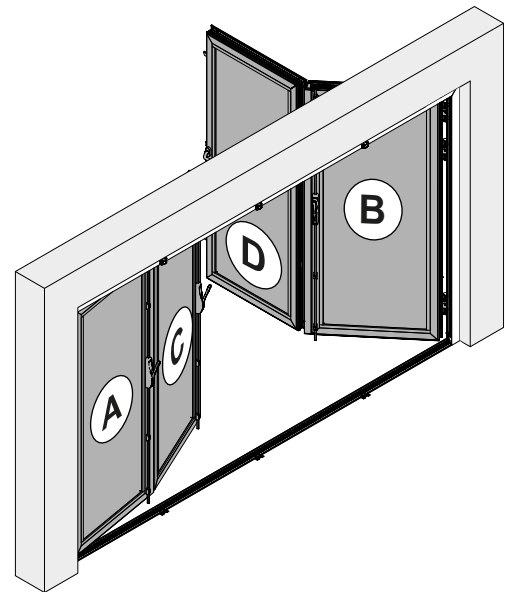

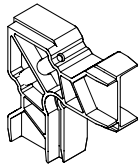
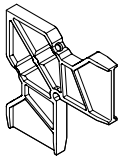
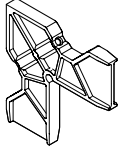

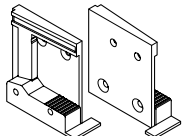
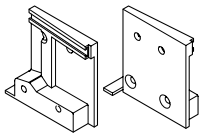

EAG

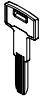

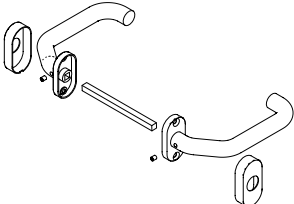
ETG

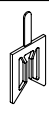
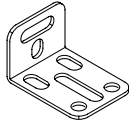
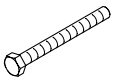

Pièces fournies / Parts supplied / Gelieferte Teile			
a			x2
b		Si ouverture intérieure If inside opening Bei Öffnung nach innen	x2
c		Si ouverture extérieure If outside opening Bei Öffnung nach außen	x2
d			x8
e	 M5 x 25		x8
f		Si ouverture intérieure If inside opening Bei Öffnung nach innen	x2
g		Si ouverture extérieure If outside opening Bei Öffnung nach außen	x2
h			x2
i	 M4,2 x 32		x4
l			x24
m			x12
n			x5
p	 M4 x 16		x8
q			x1
r			x3

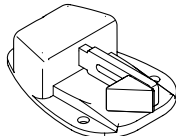
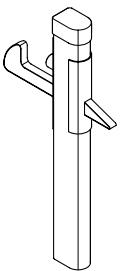

Pièces fournies / Parts supplied / Gelieferte Teile			
s			x10
t		Si fixation applique If build in Bei Option hinter der Öffnung	x10
u	 M8 x 80	Si fixation applique If build in Bei Option hinter der Öffnung	x8
v	 M8	Si fixation applique If build in Bei Option hinter der Öffnung	x10
w	 M8 x 20	Si fixation applique If build in Bei Option hinter der Öffnung	x2
aa		Si option arrêt de porte à visser If screw-on door stop option Bei Option Türfeststeller zum Anschrauben	x1
bb		Si option arrêt de porte à sceller If door stop to seal option Bei Option Türstopper zum Versiegeln	x1
jj	Notice de montage Installation instruction Montageanleitung	NFF16602_C	x1

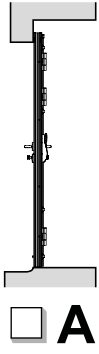

1

Applique
Hinter der Öffnung
Build on



-  (FR) Surfaces planes, de niveau et d'aplomb
-  (DE) Flächen müssen eben und lotrecht sein
-  (GB) Surfaces must be flat and plumb

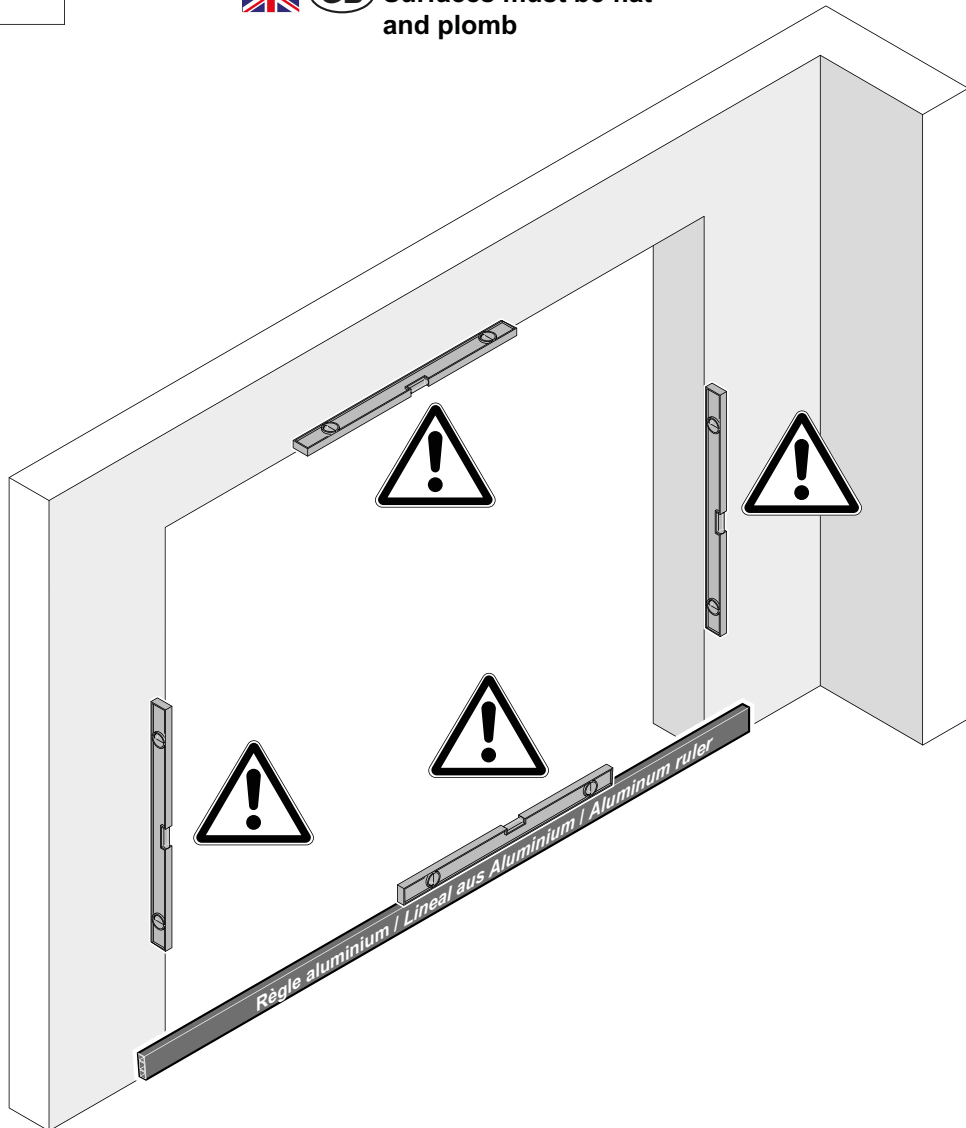

2

Tunnel
In der Öffnung
Build in

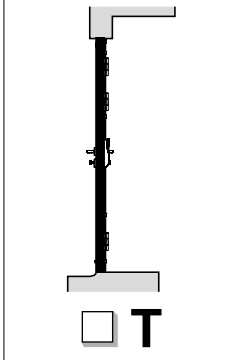

FR Surfaces planes,
de niveau et d'aplomb



DE Flächen müssen eben
und lotrecht sein



GB Surfaces must be flat
and plumb

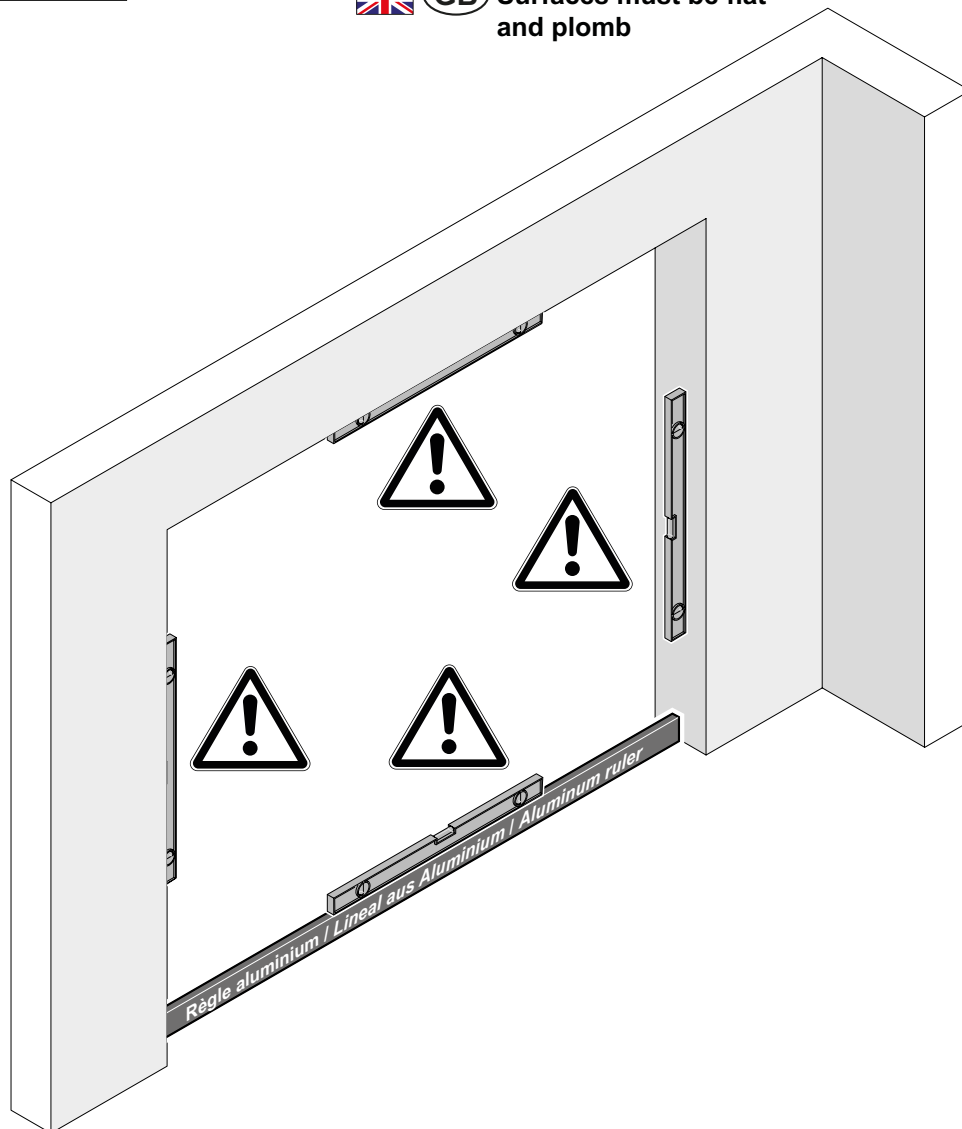

3

Applique
Hinter der Öffnung
Build on

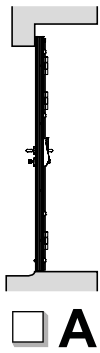

A

Extérieure
Nach Außen
To the outside

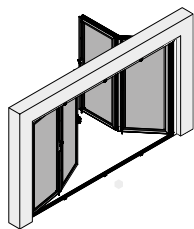

E

250 mm maximum

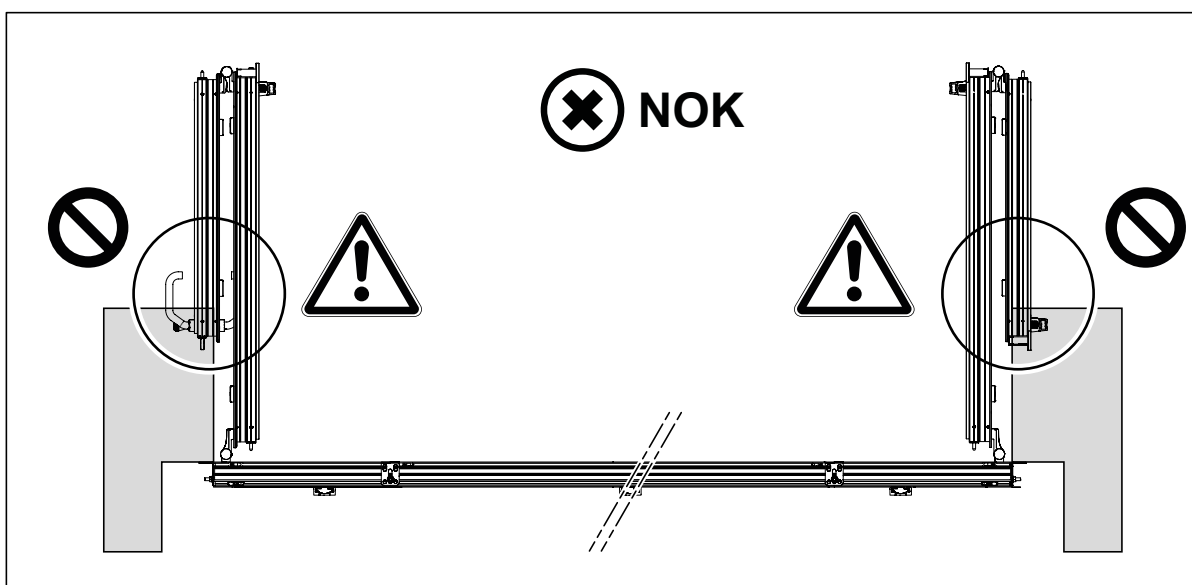
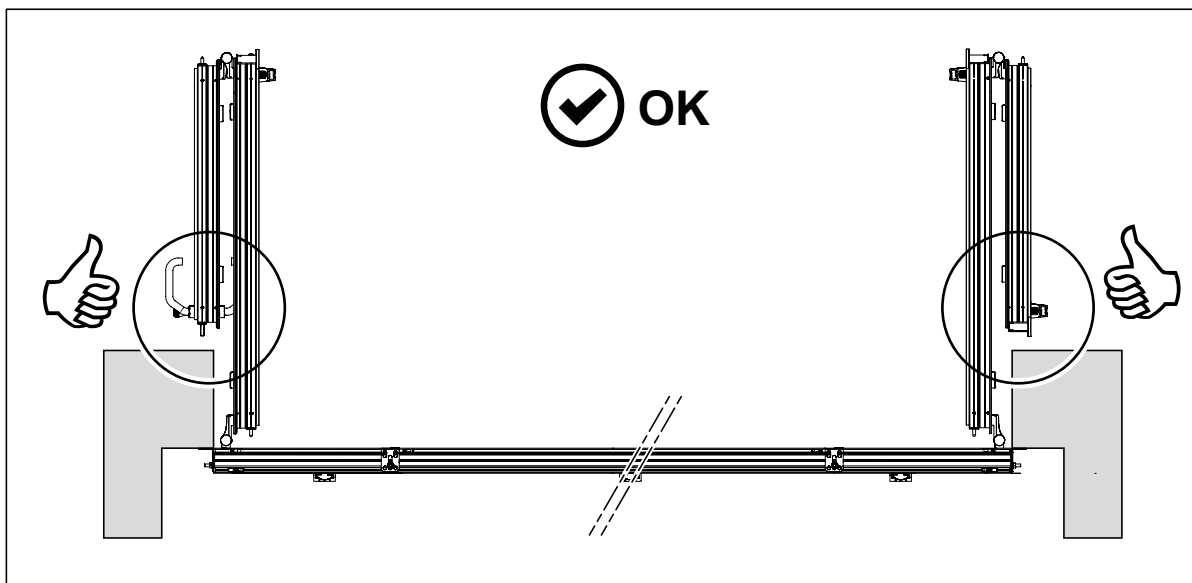
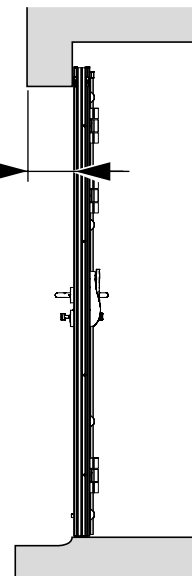

Tunnel
In der Öffnung
Build in

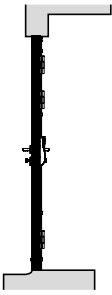

T

Extérieure
Nach Außen
To the outside

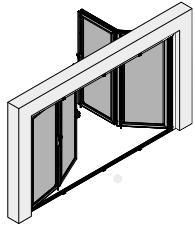

E

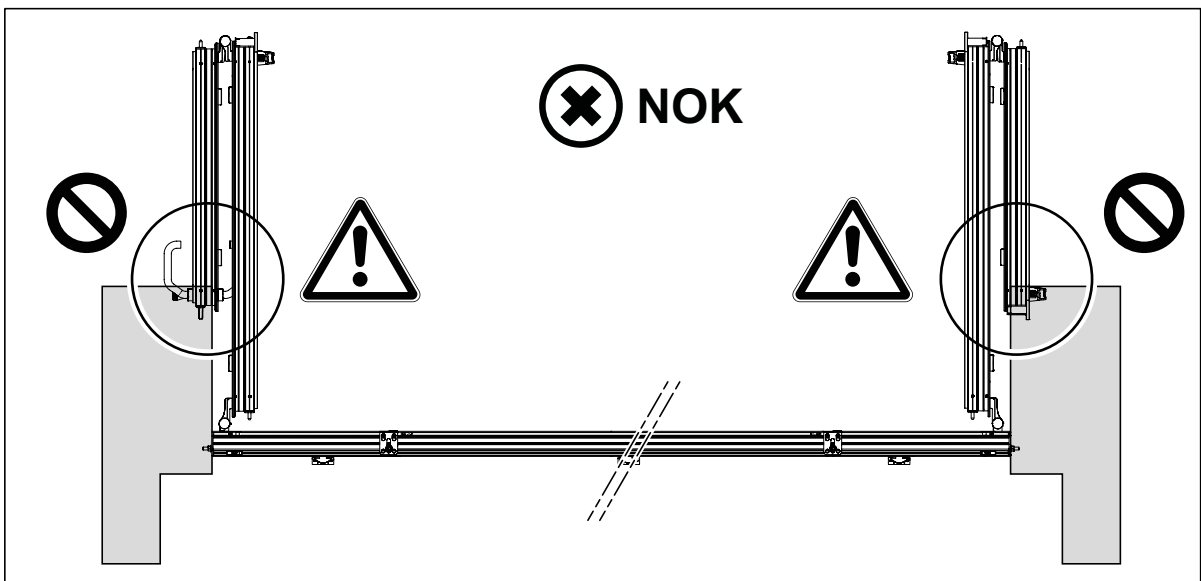
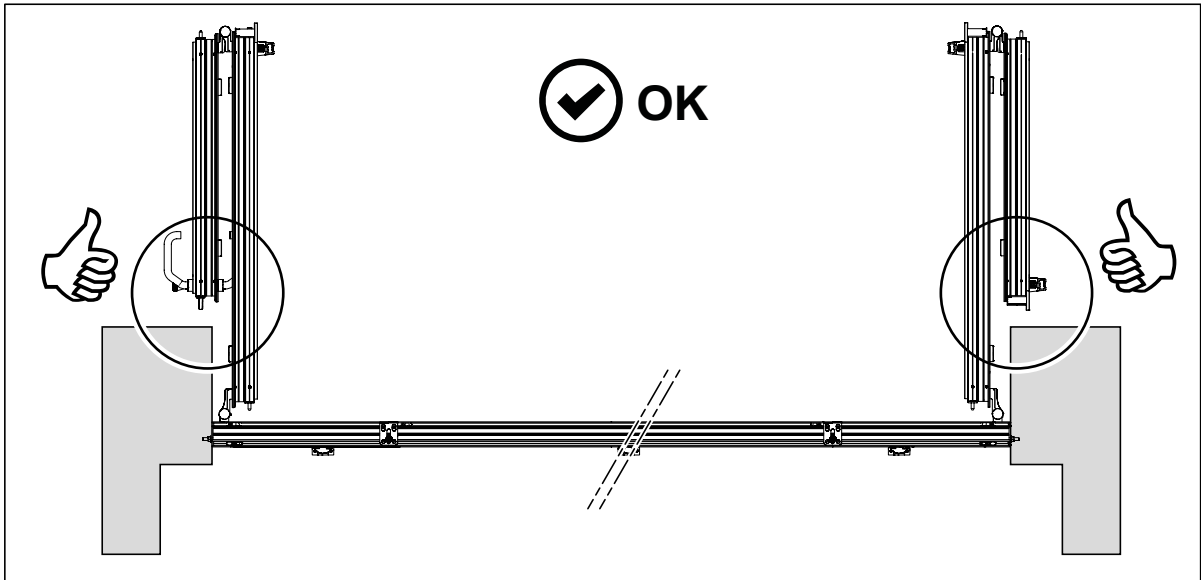
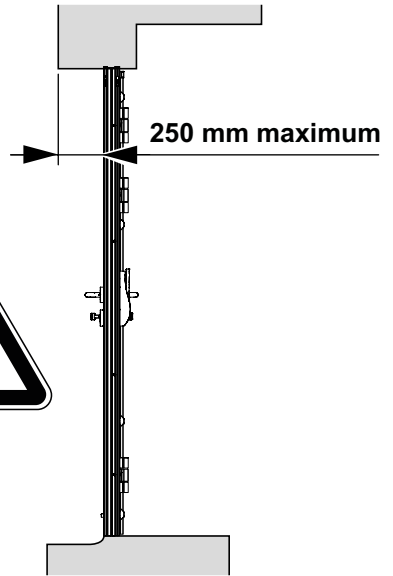

Tunnel
In der Öffnung
Build in

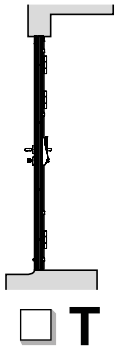

Intérieure
Nach Innen
To the inside

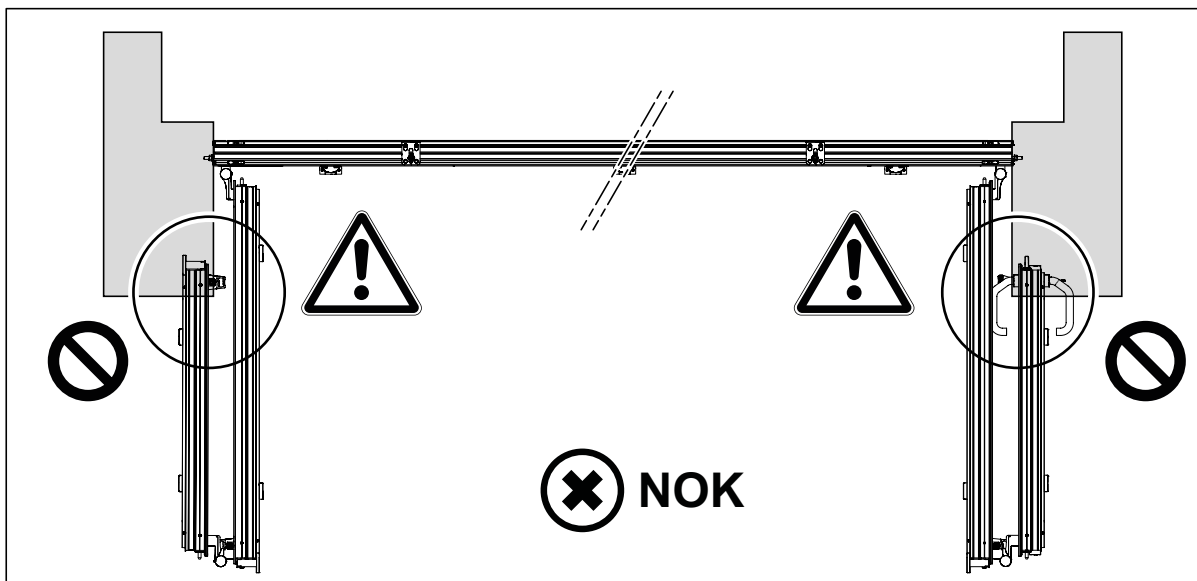
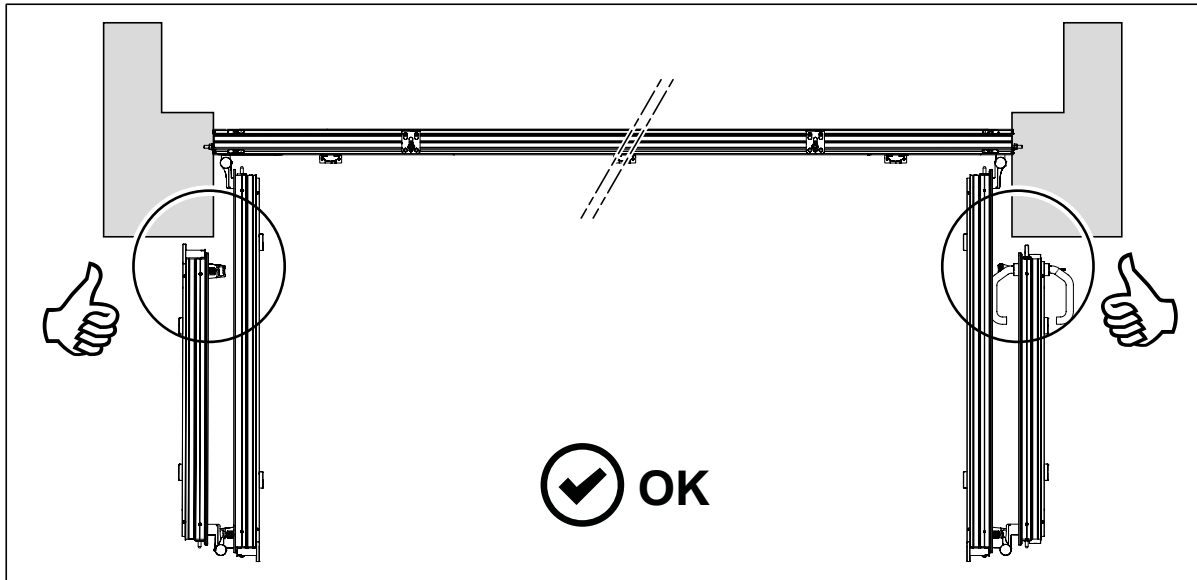
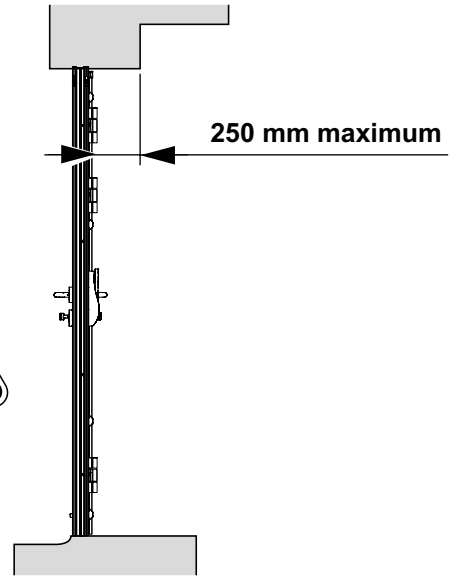
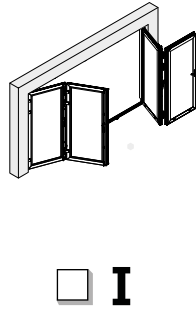

4

Applique
Hinter der Öffnung
Build on

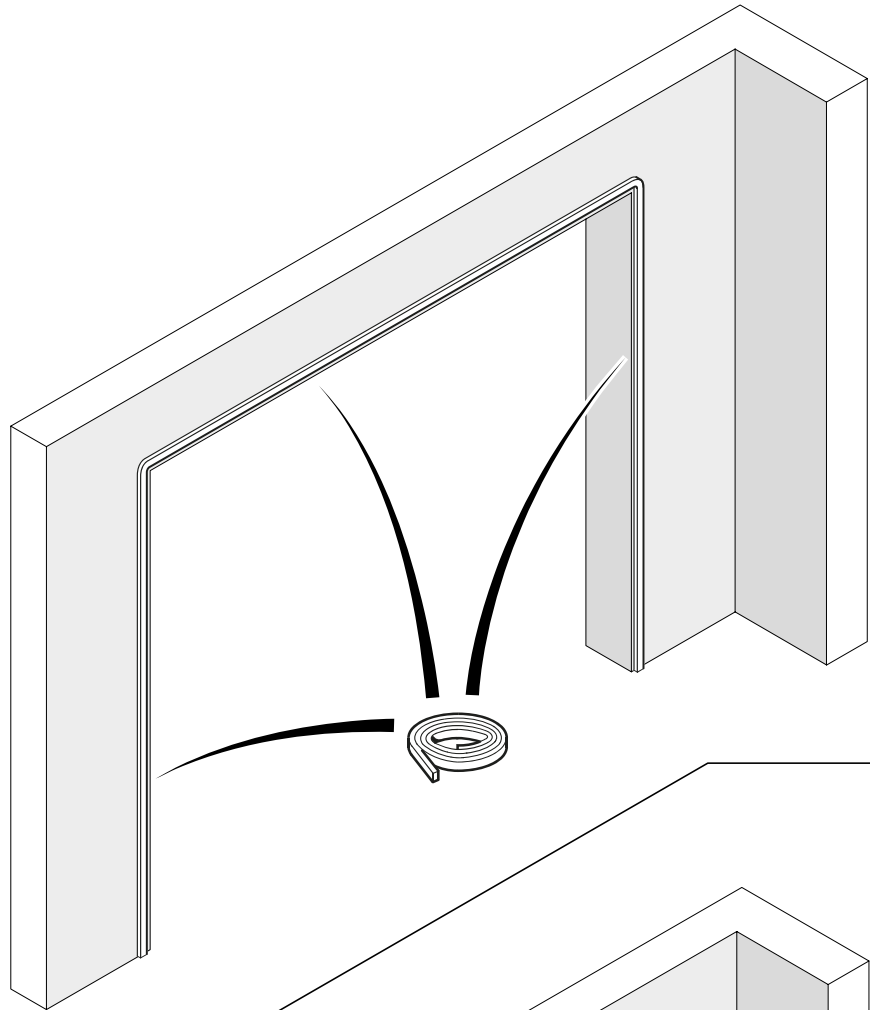
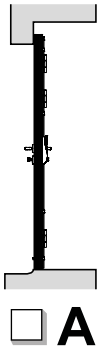

Tunnel
In der Öffnung
Build in

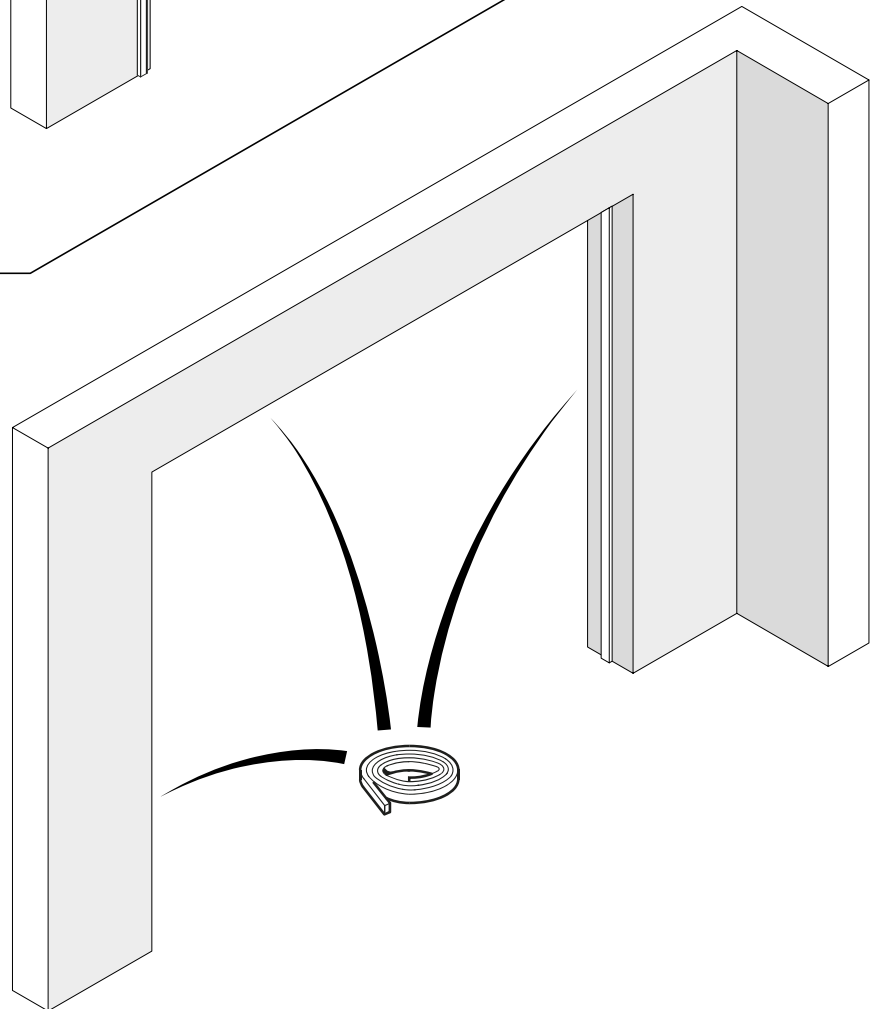
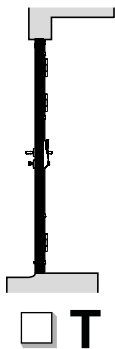

5

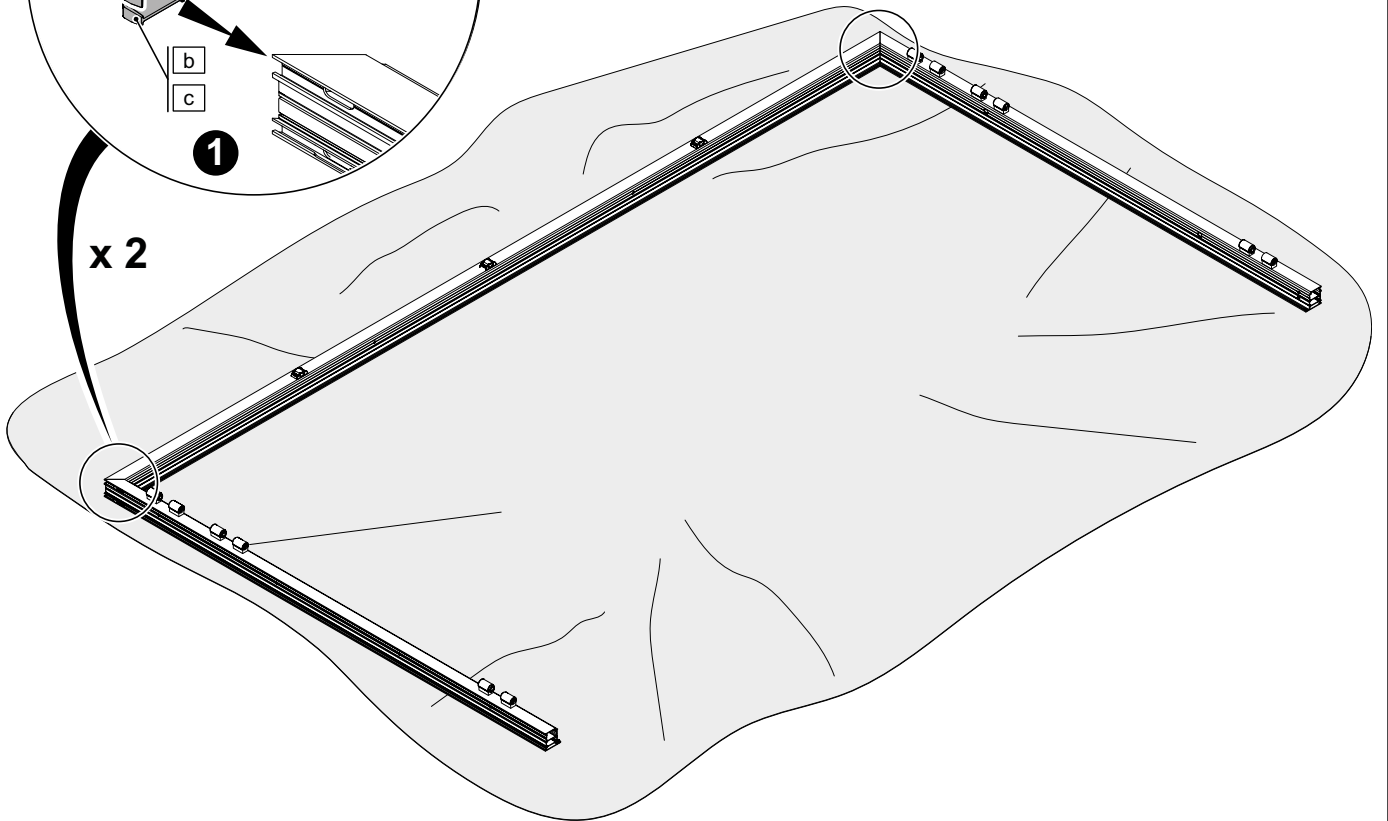
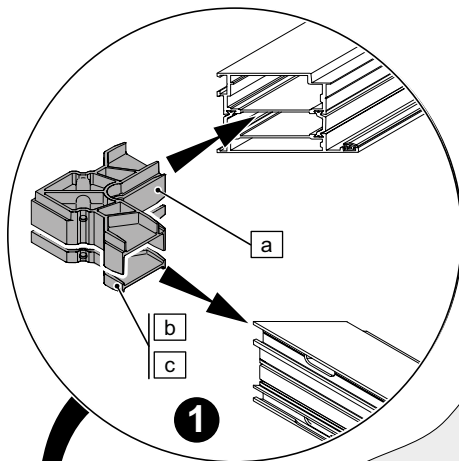
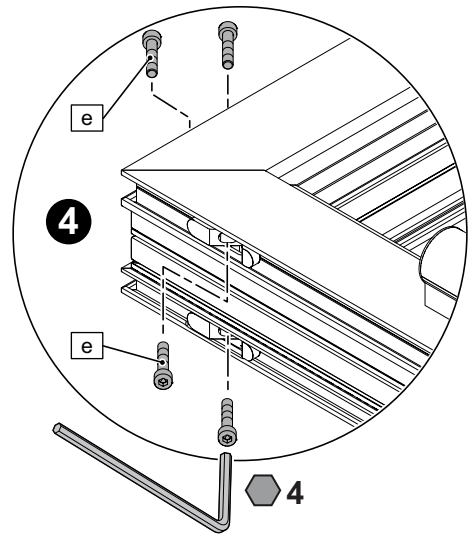
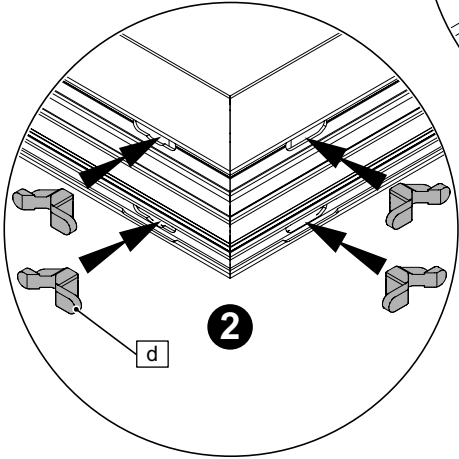
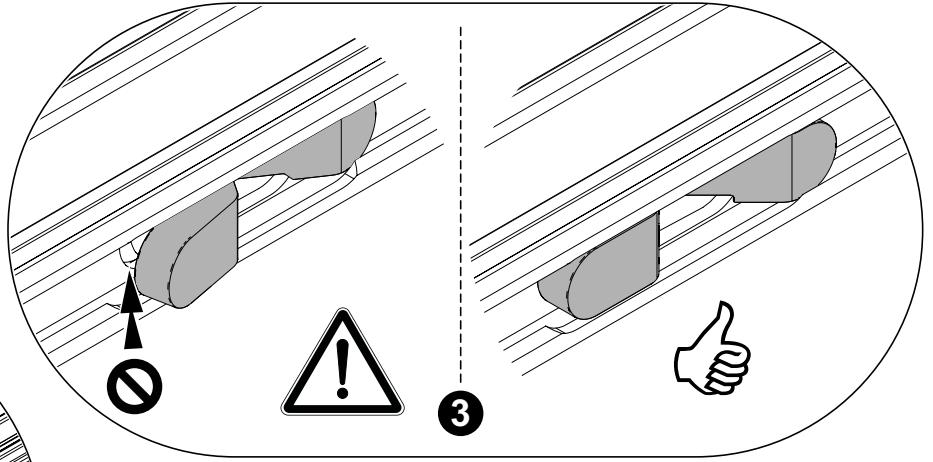

6

Intérieure
Nach Innen
To the inside

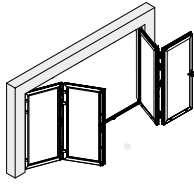

I

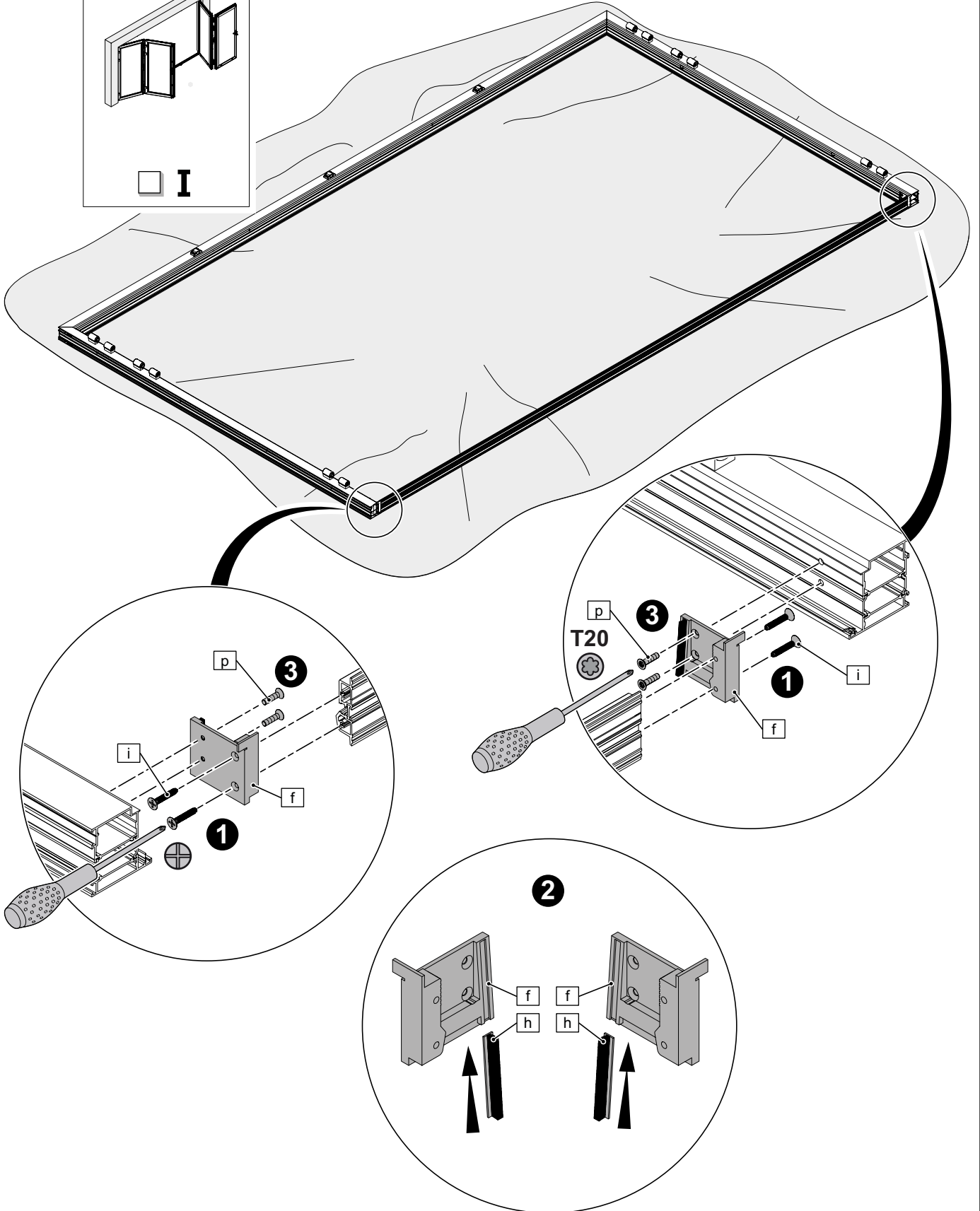

7

Extérieure
Nach Außen
To the outside

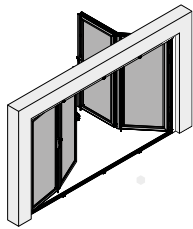

□ E

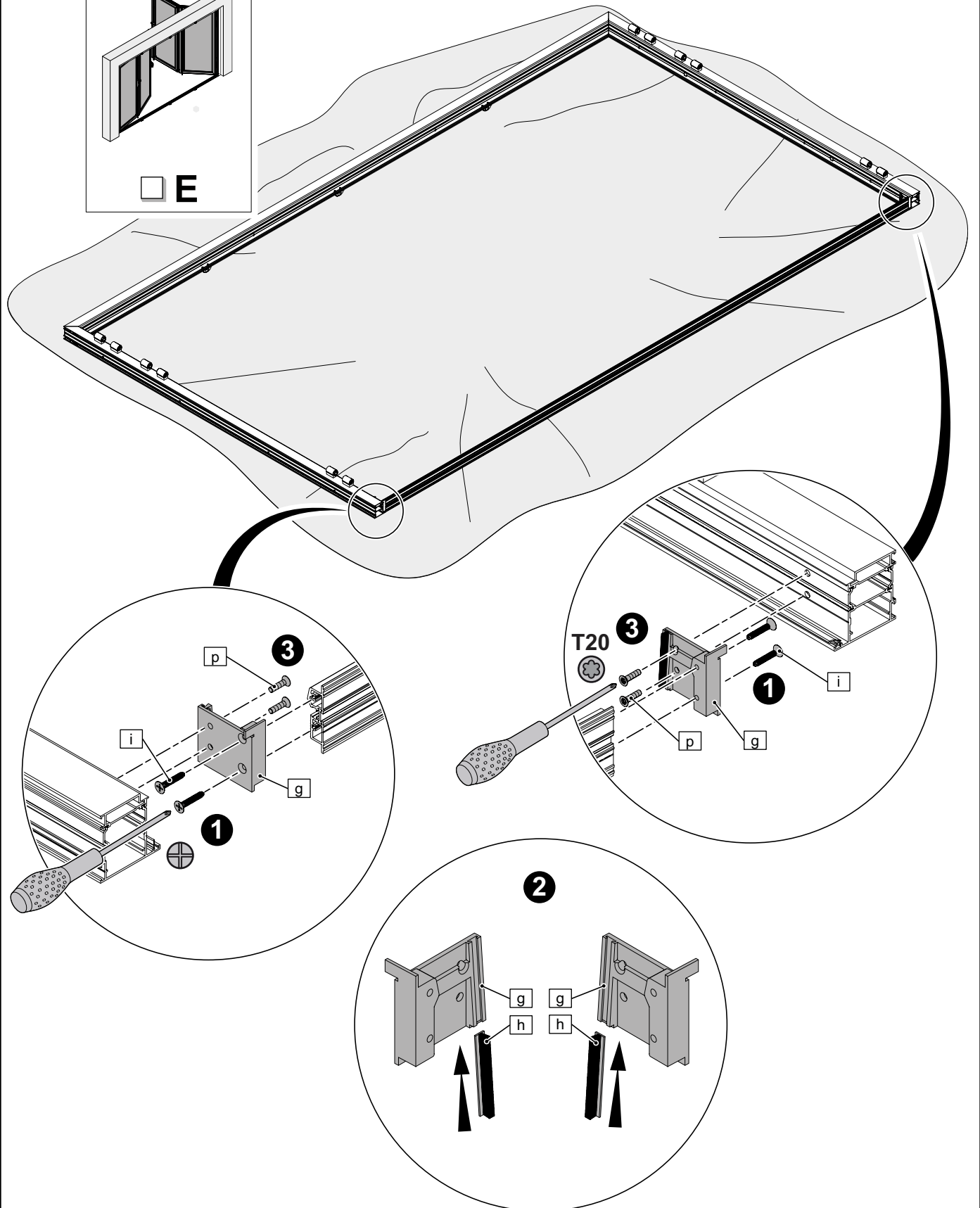

8

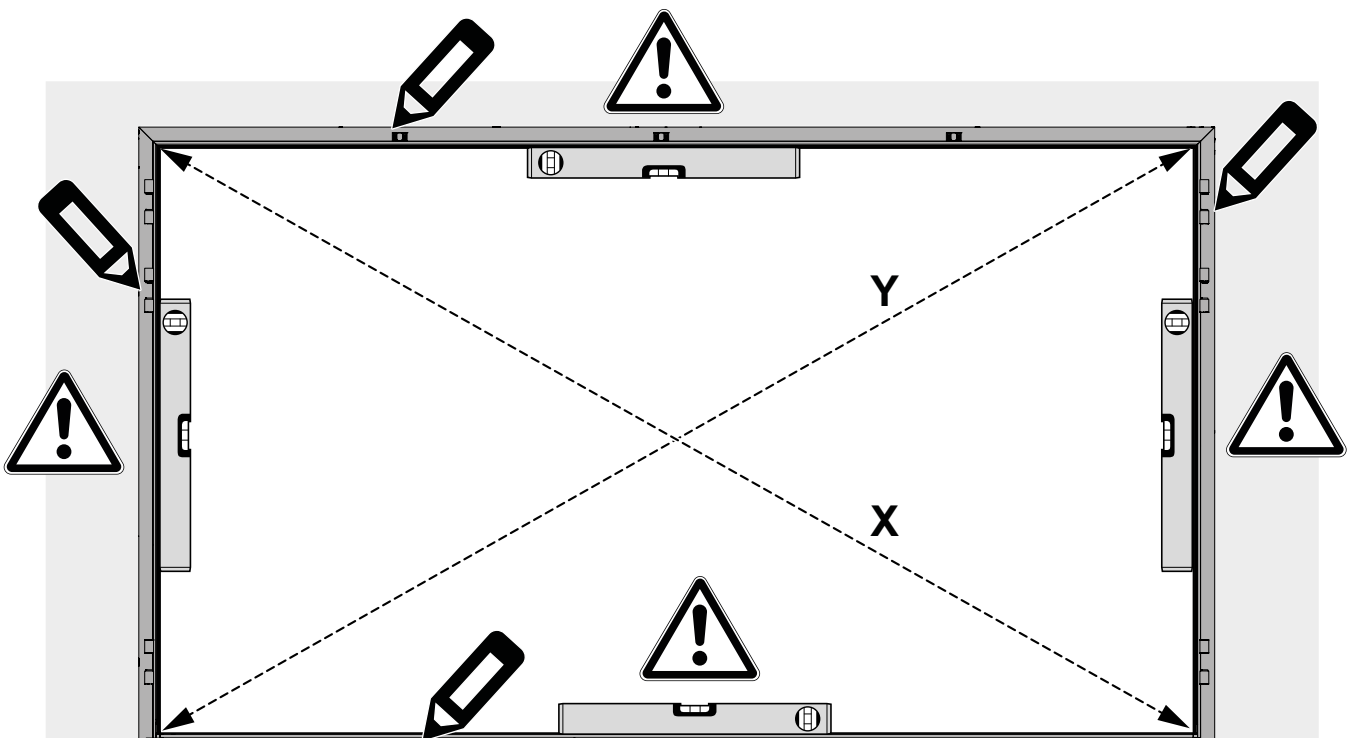

09

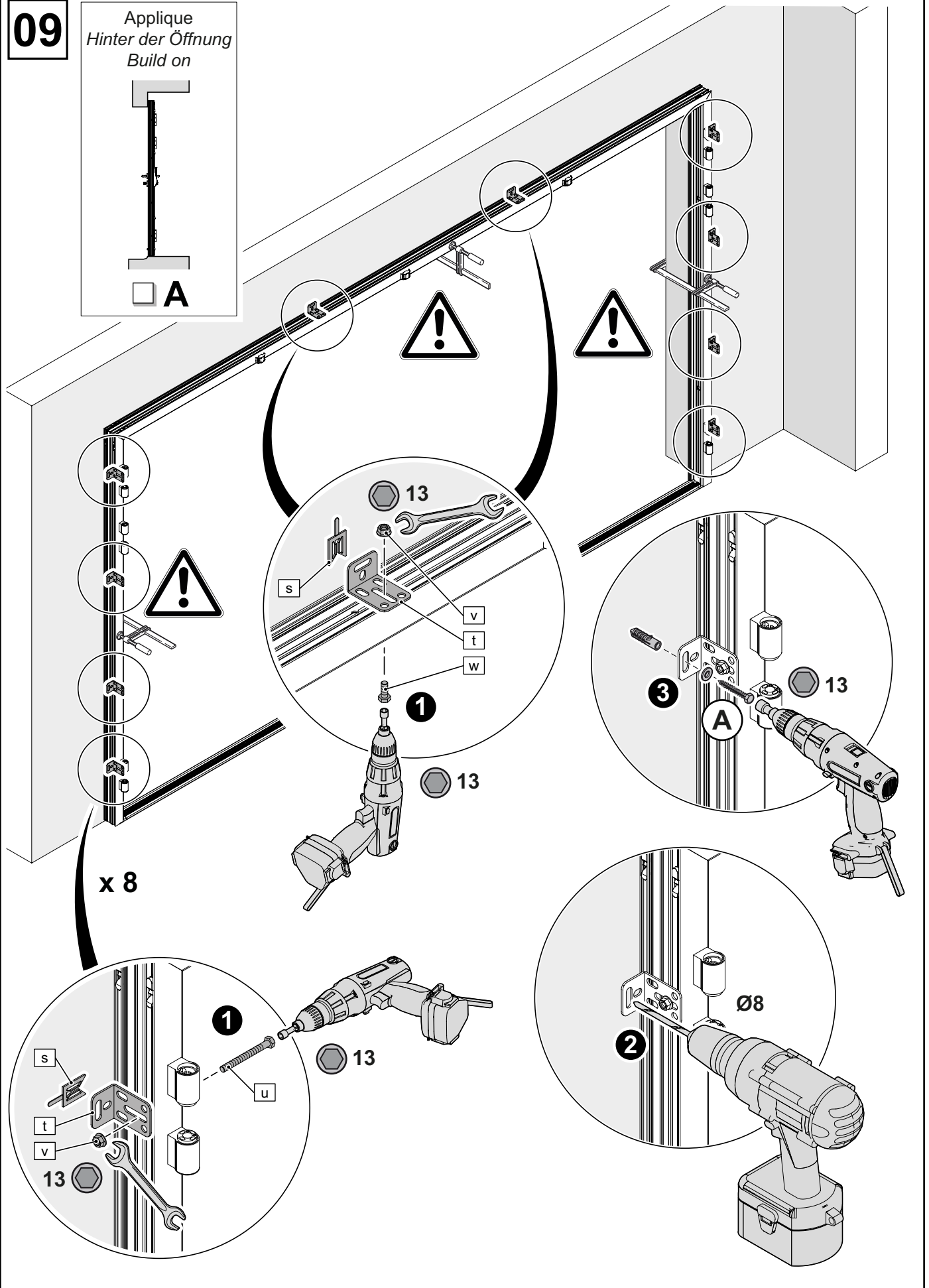
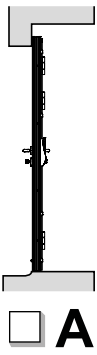

Applique
Hinter der Öffnung
Build on

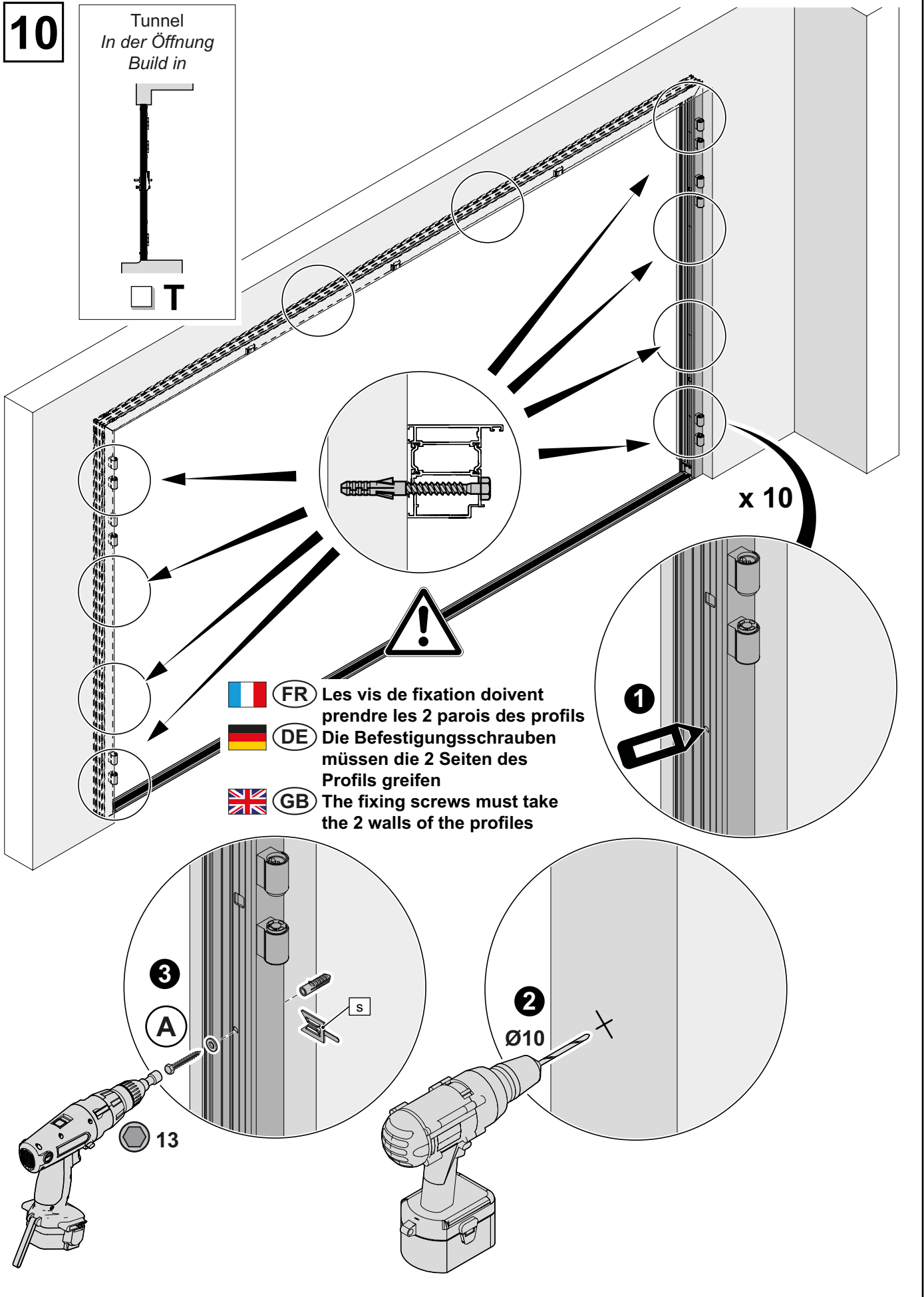
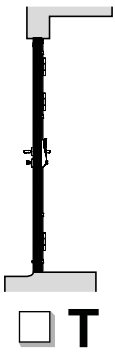

10

Tunnel
In der Öffnung
Build in



-  (FR) Les vis de fixation doivent prendre les 2 parois des profils
-  (DE) Die Befestigungsschrauben müssen die 2 Seiten des Profils greifen
-  (GB) The fixing screws must take the 2 walls of the profiles

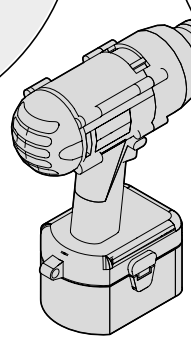
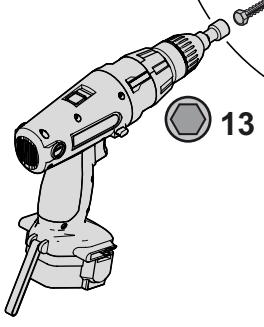
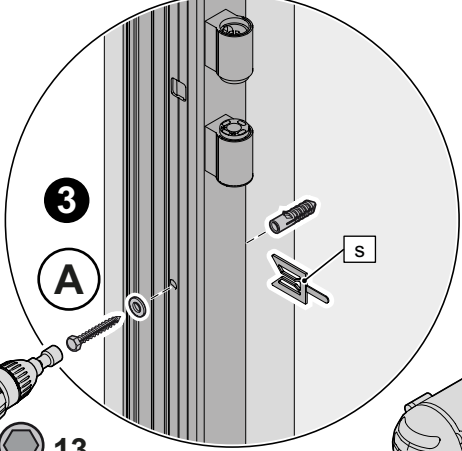
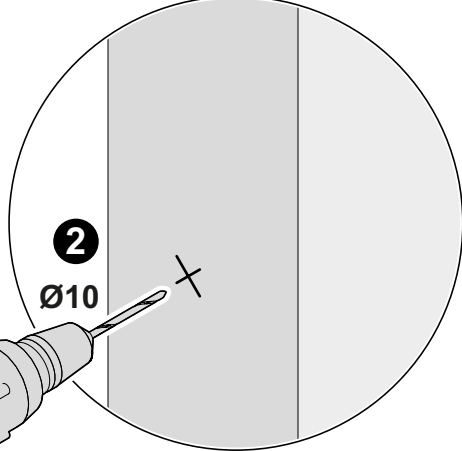
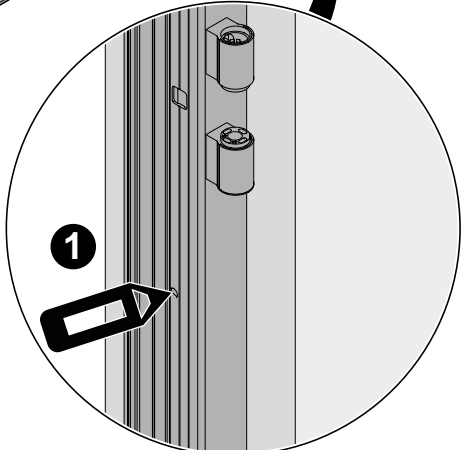

11

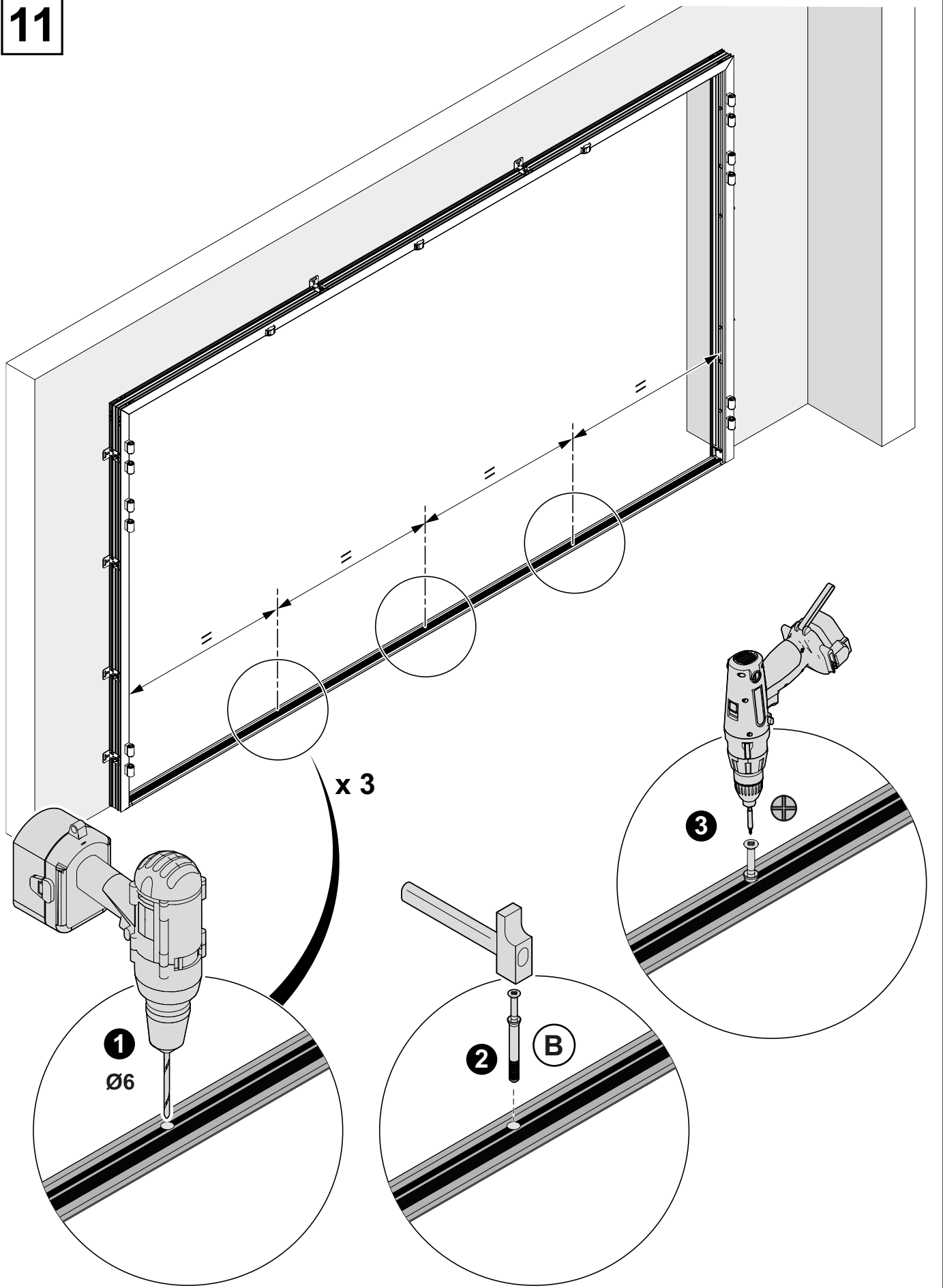

12

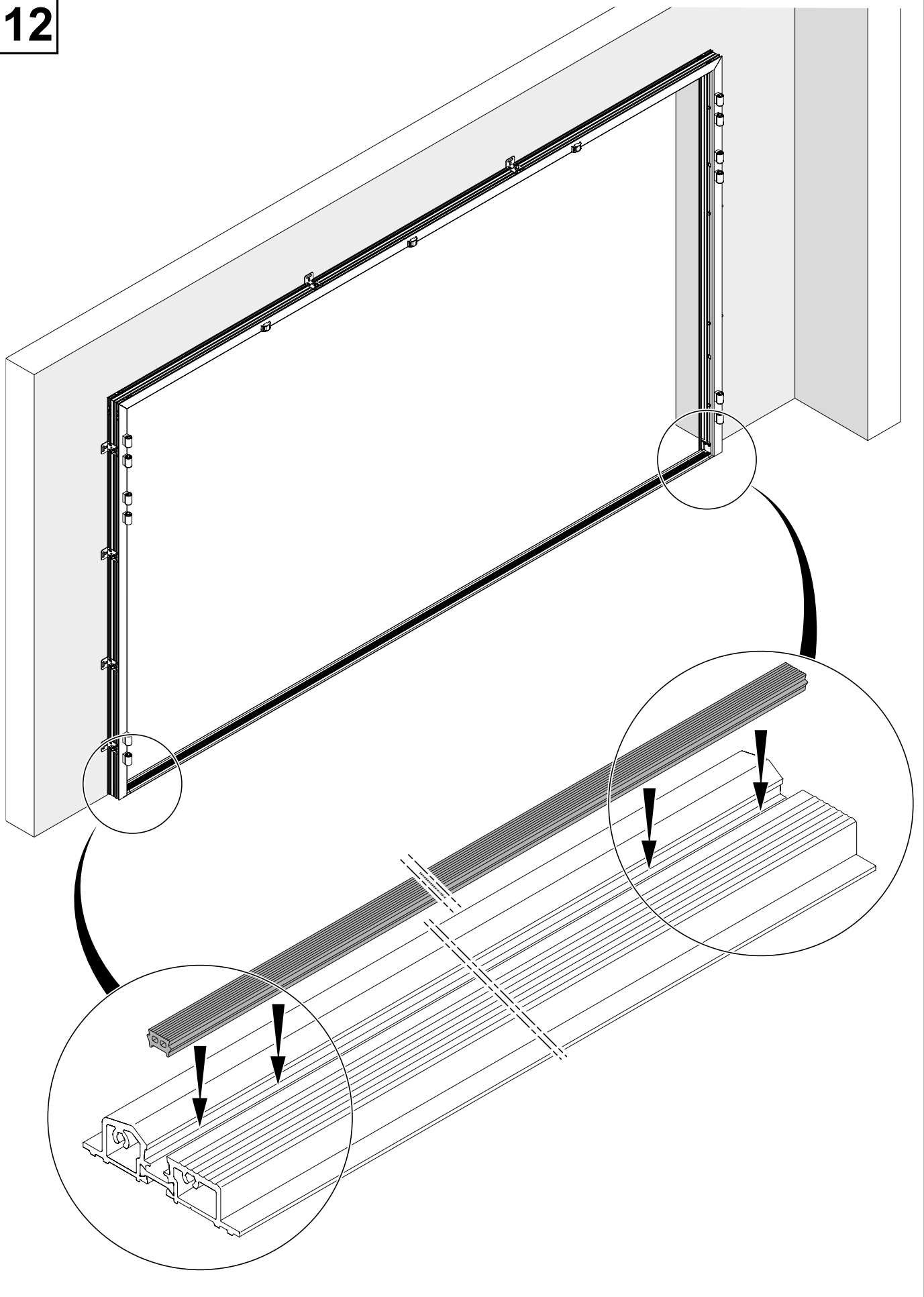

13

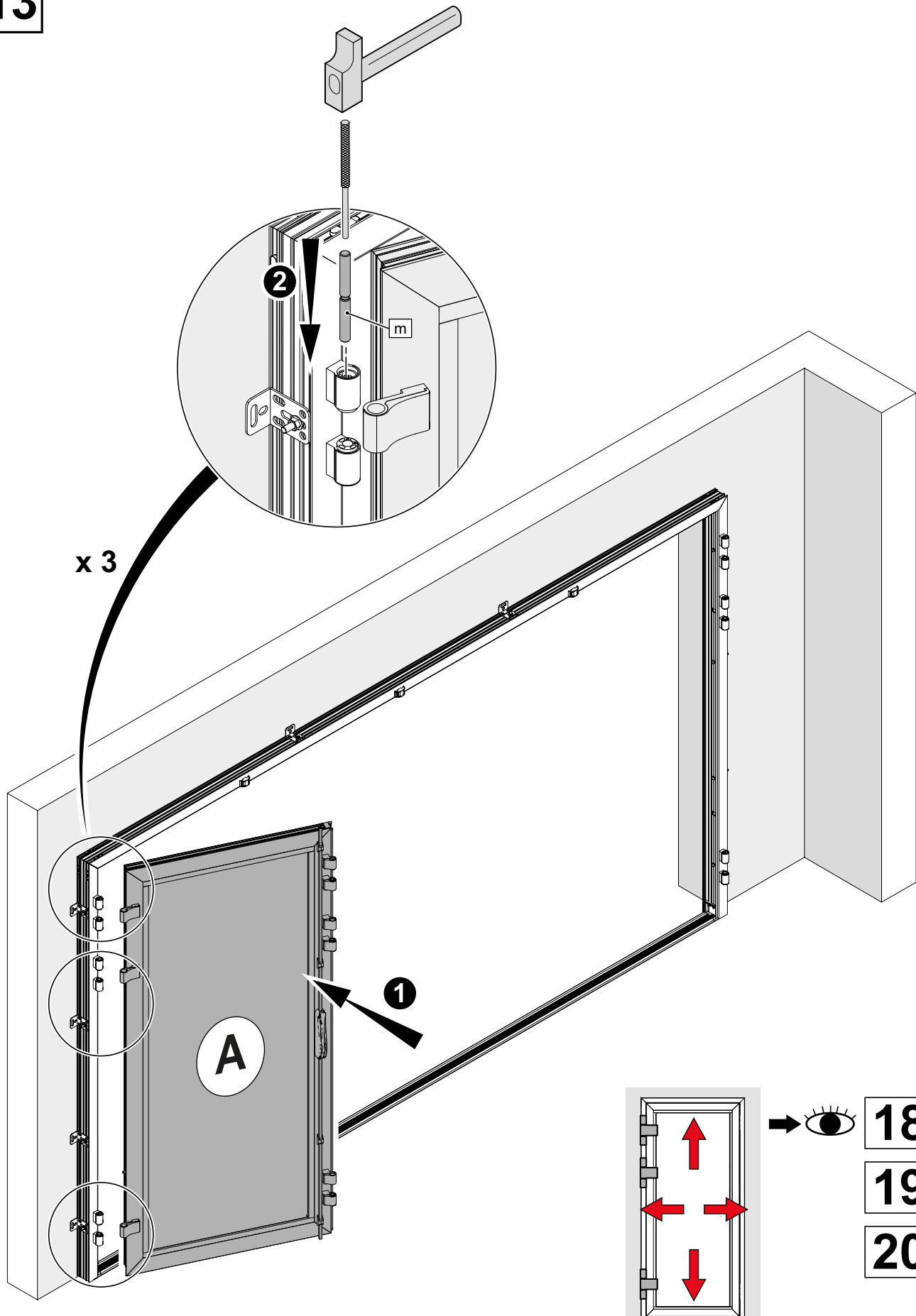

14

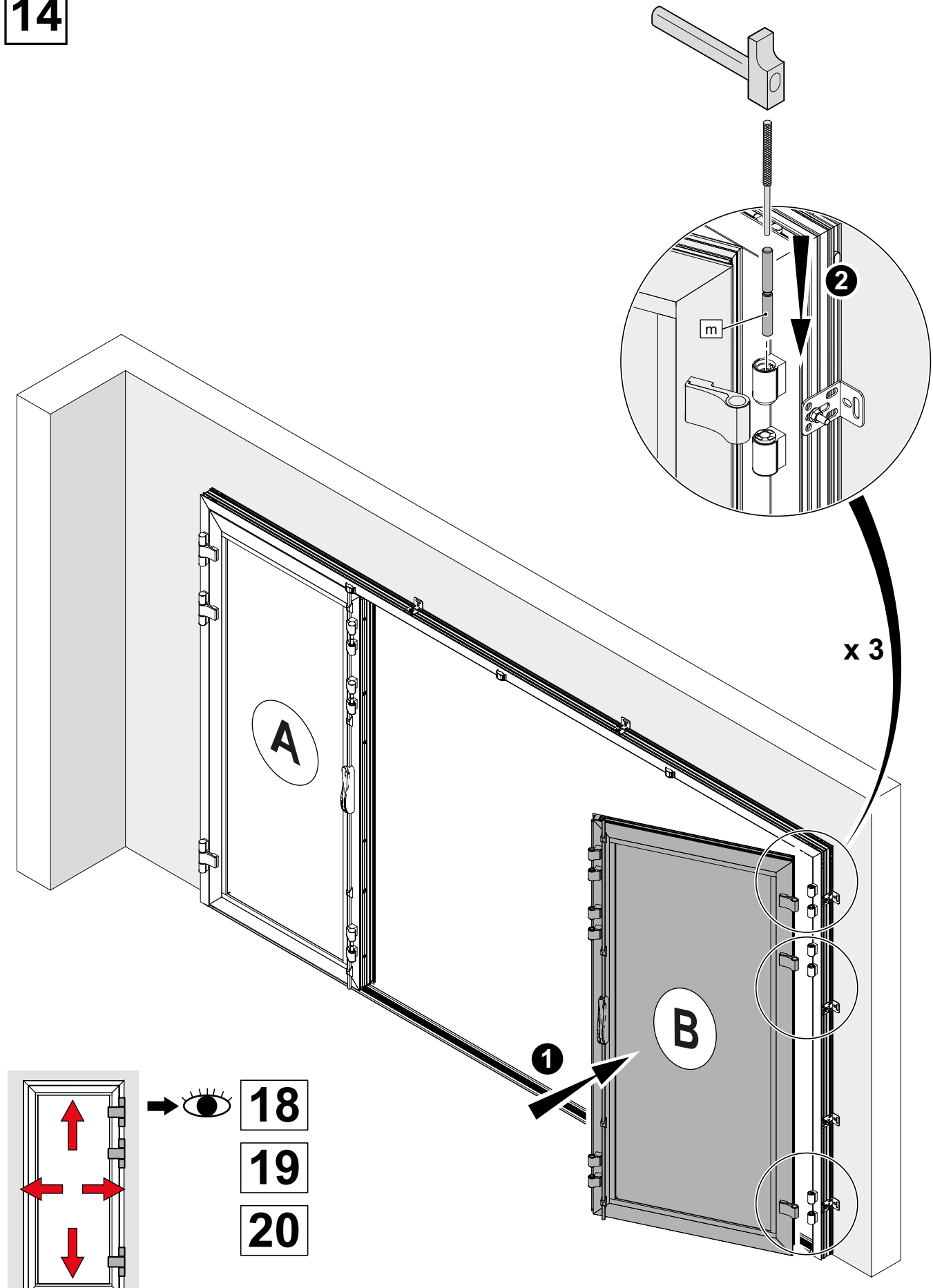

15

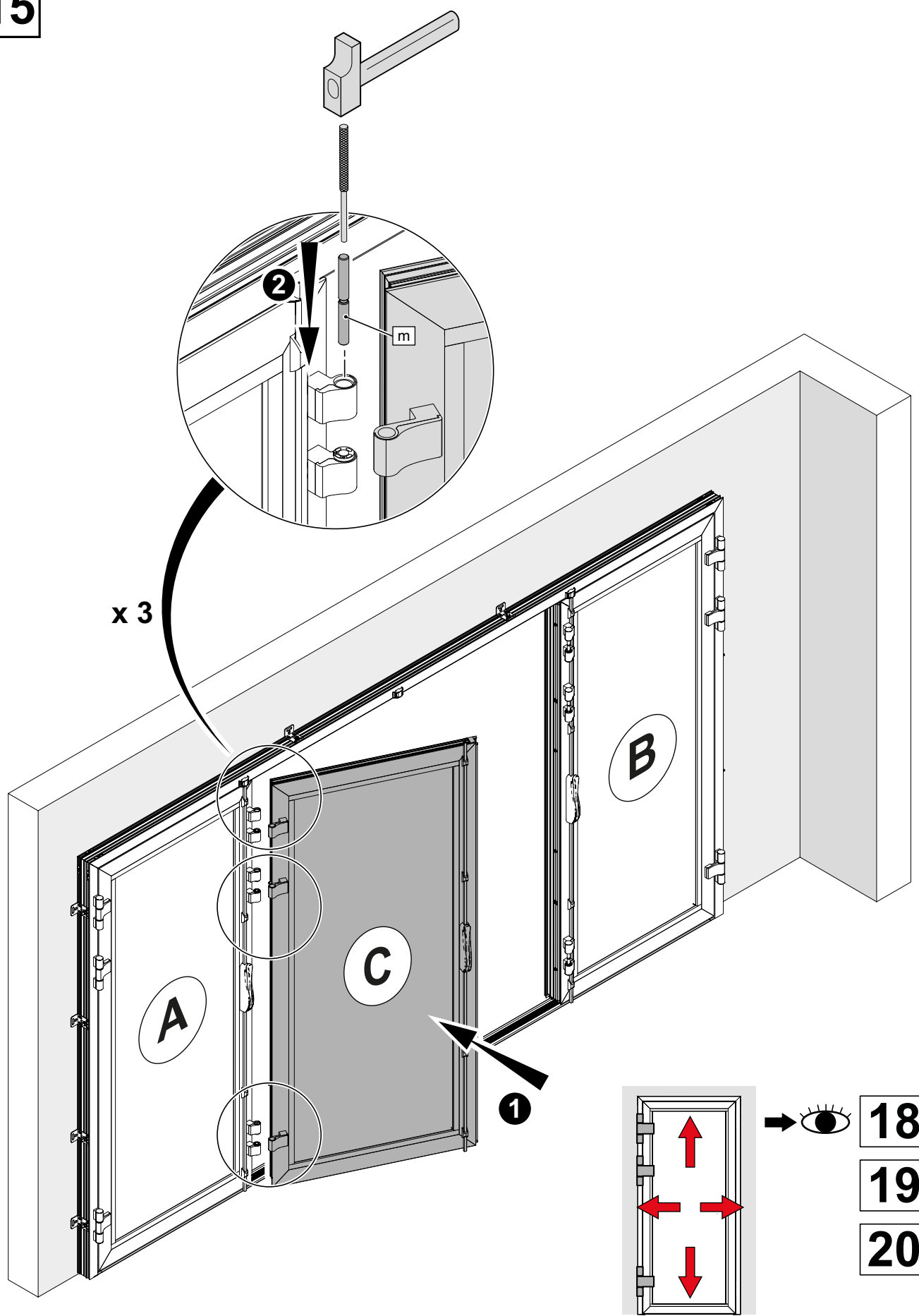

16

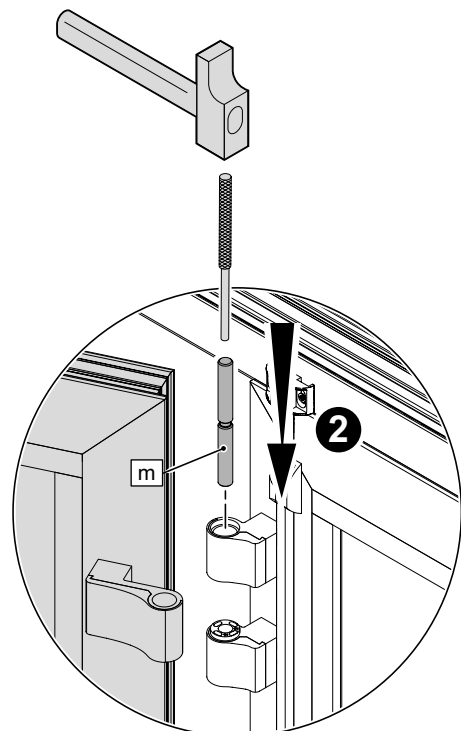

x 3

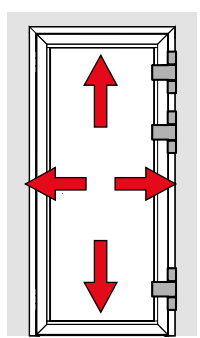
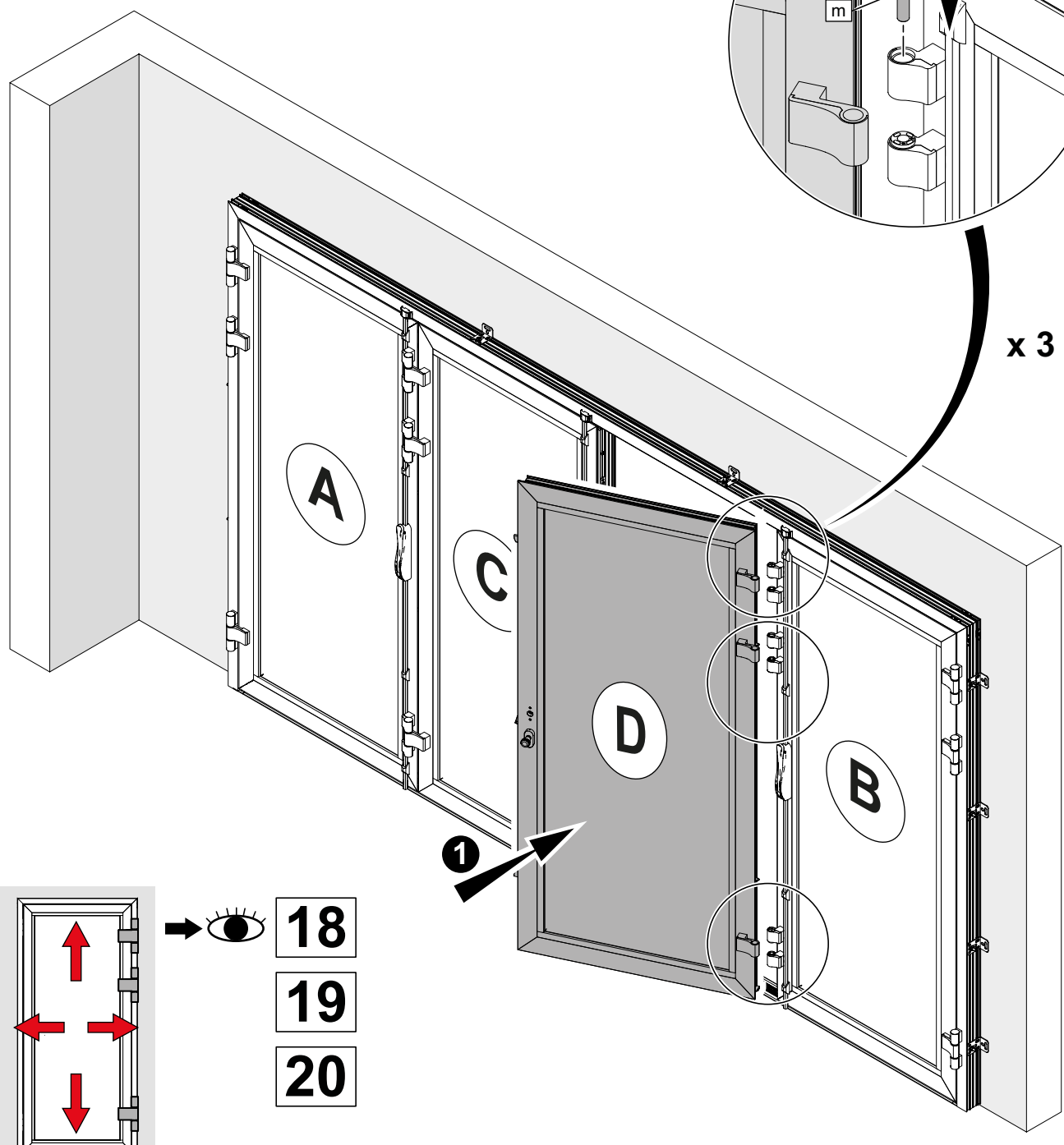

18

19

20

17

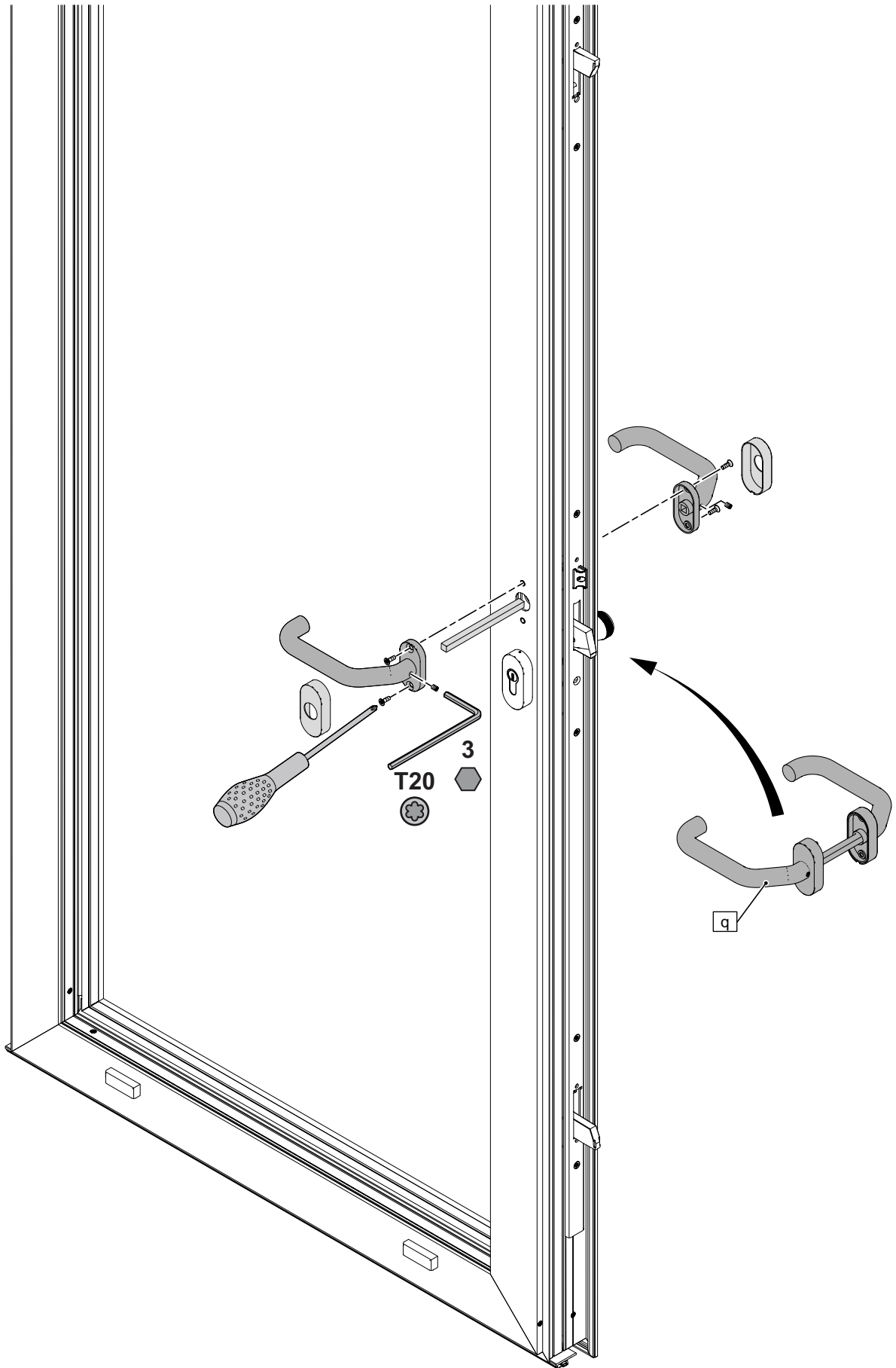

18

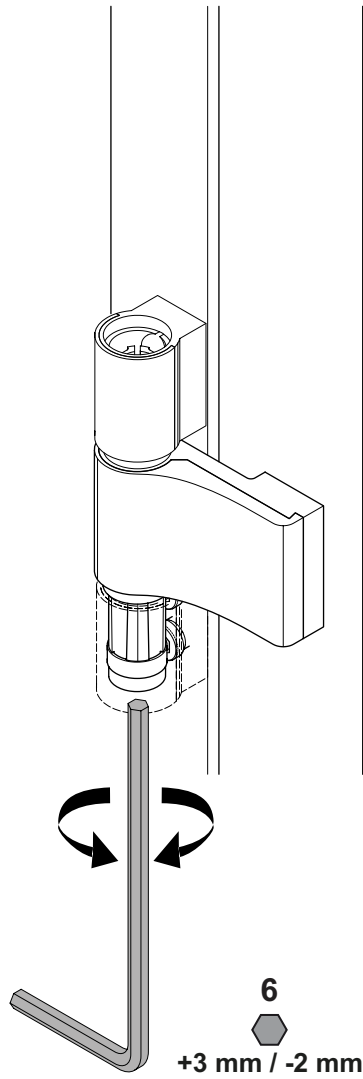
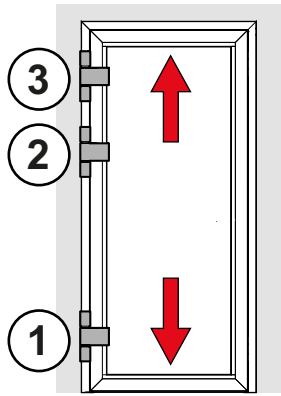

19

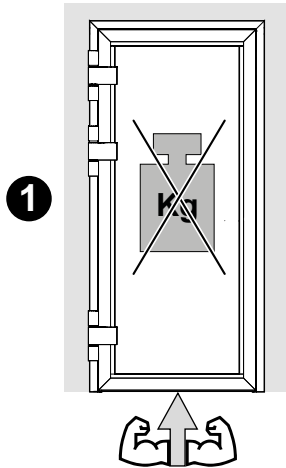
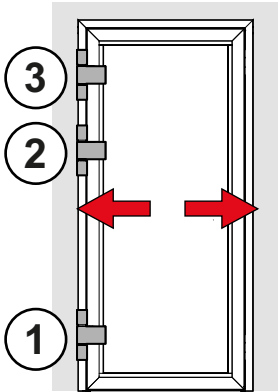

3
+2 mm / -2 mm

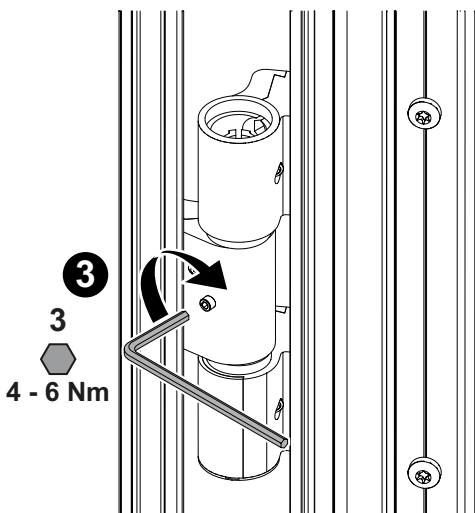
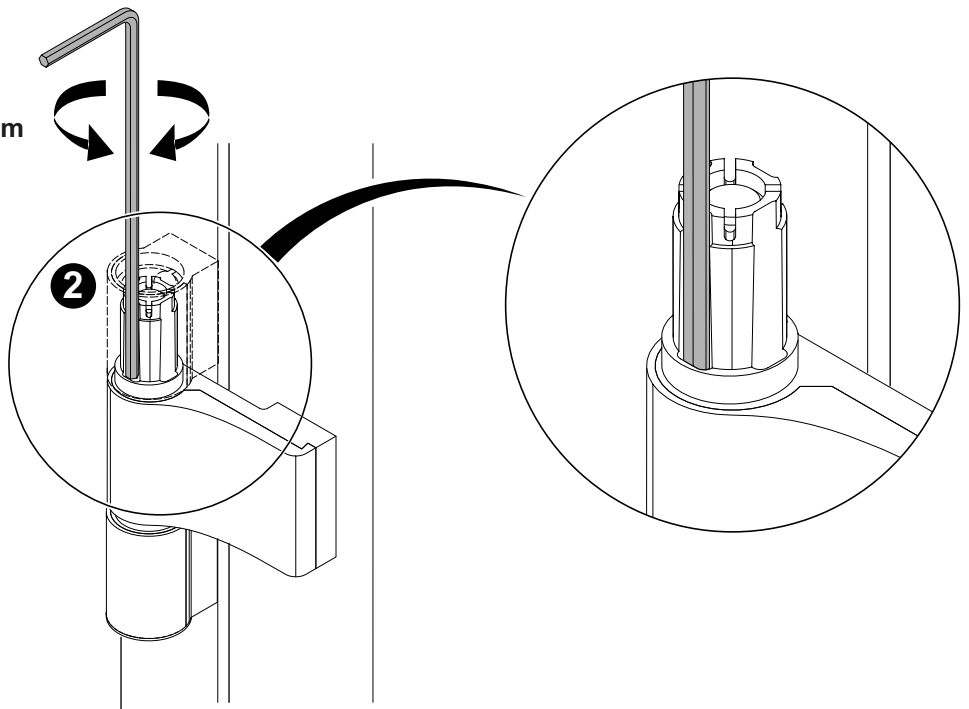

20

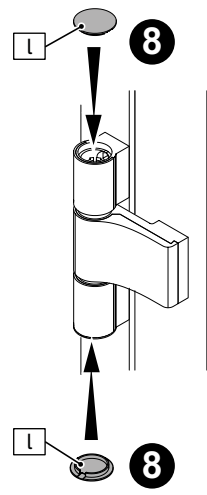
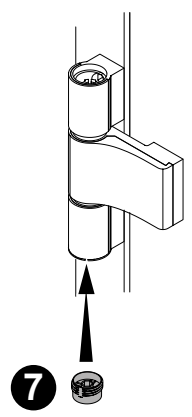
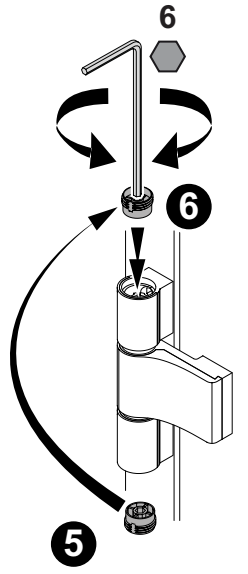
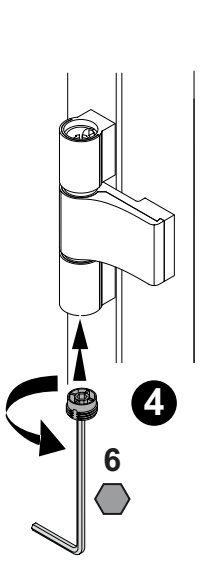
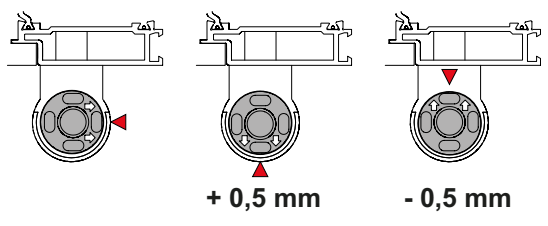
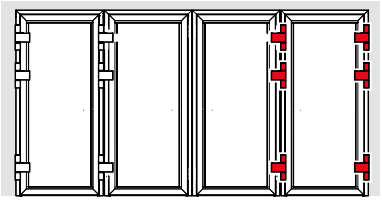
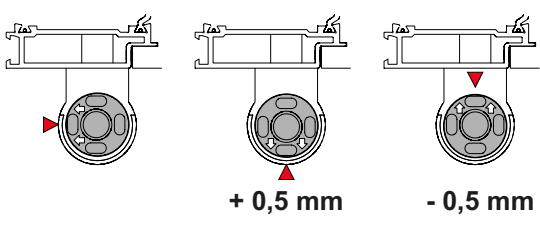
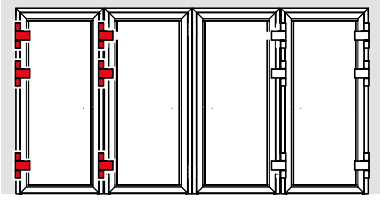
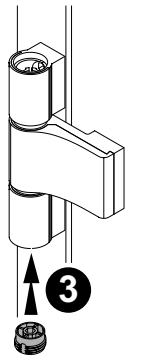
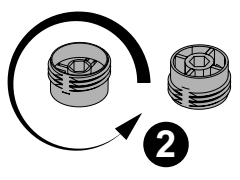
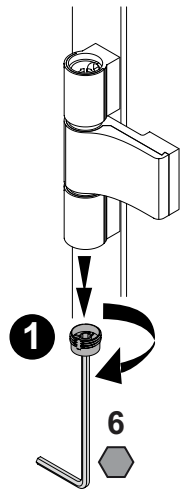
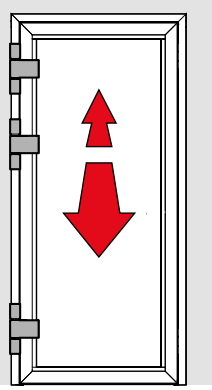

21

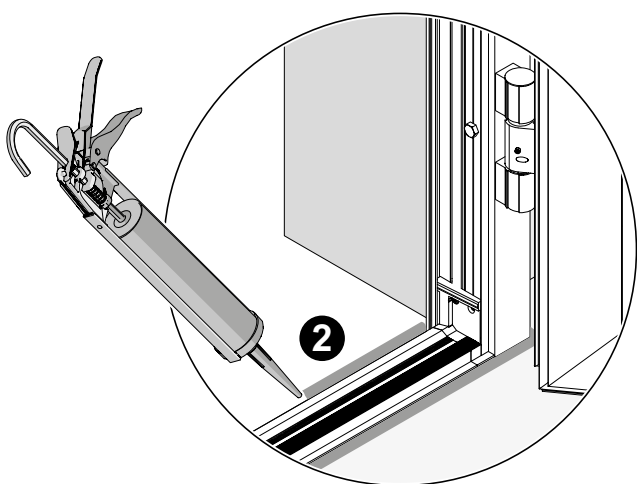
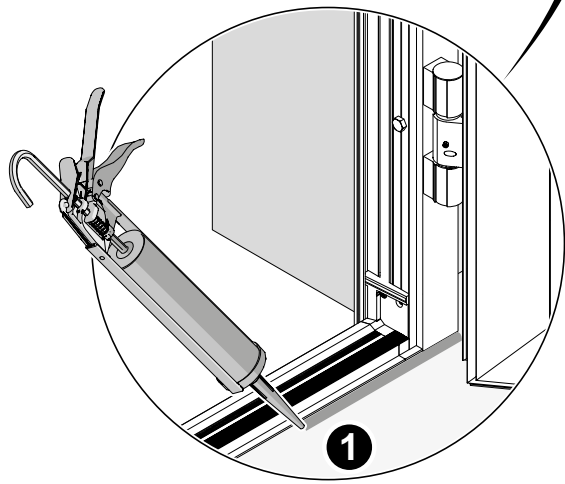
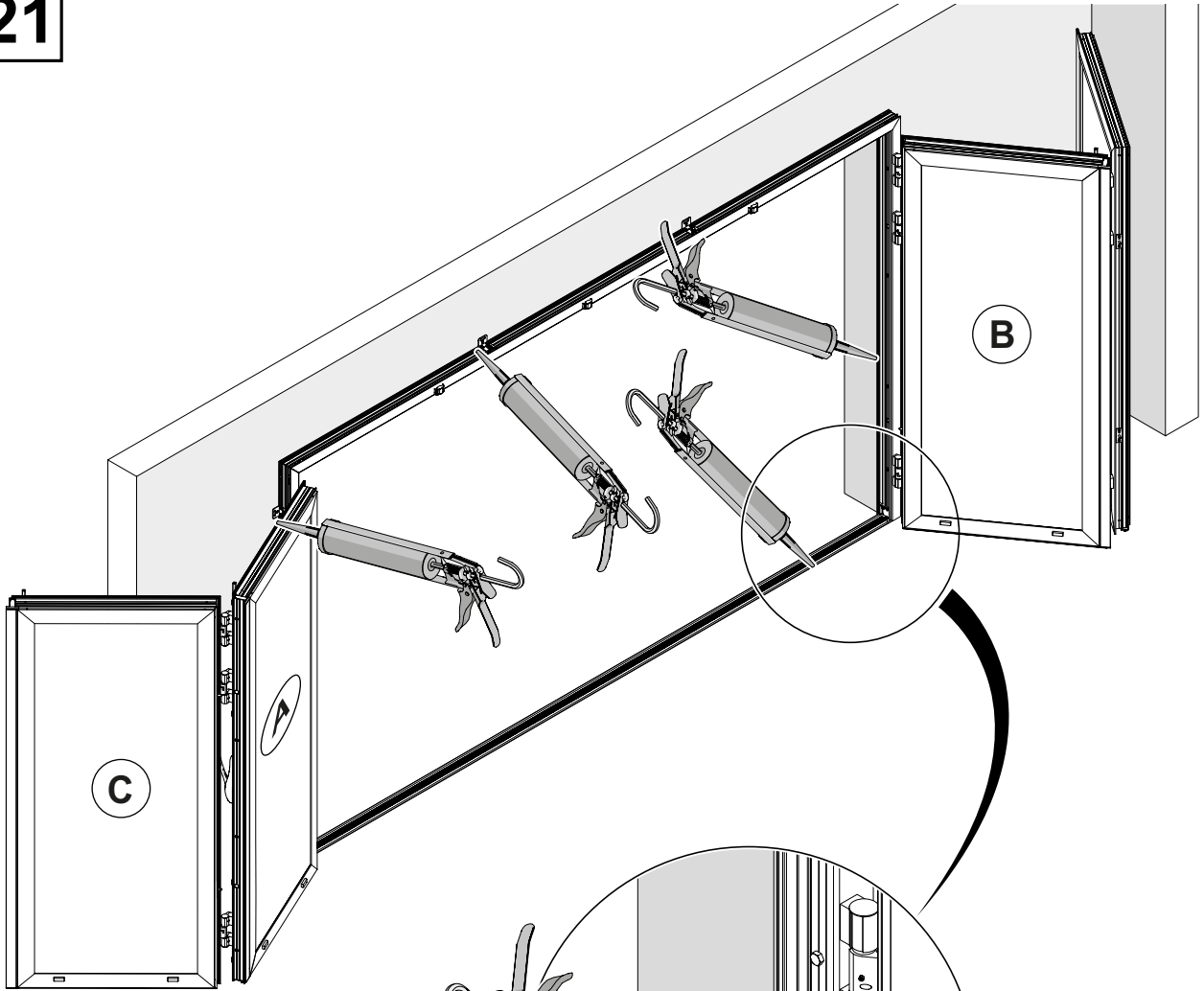

22

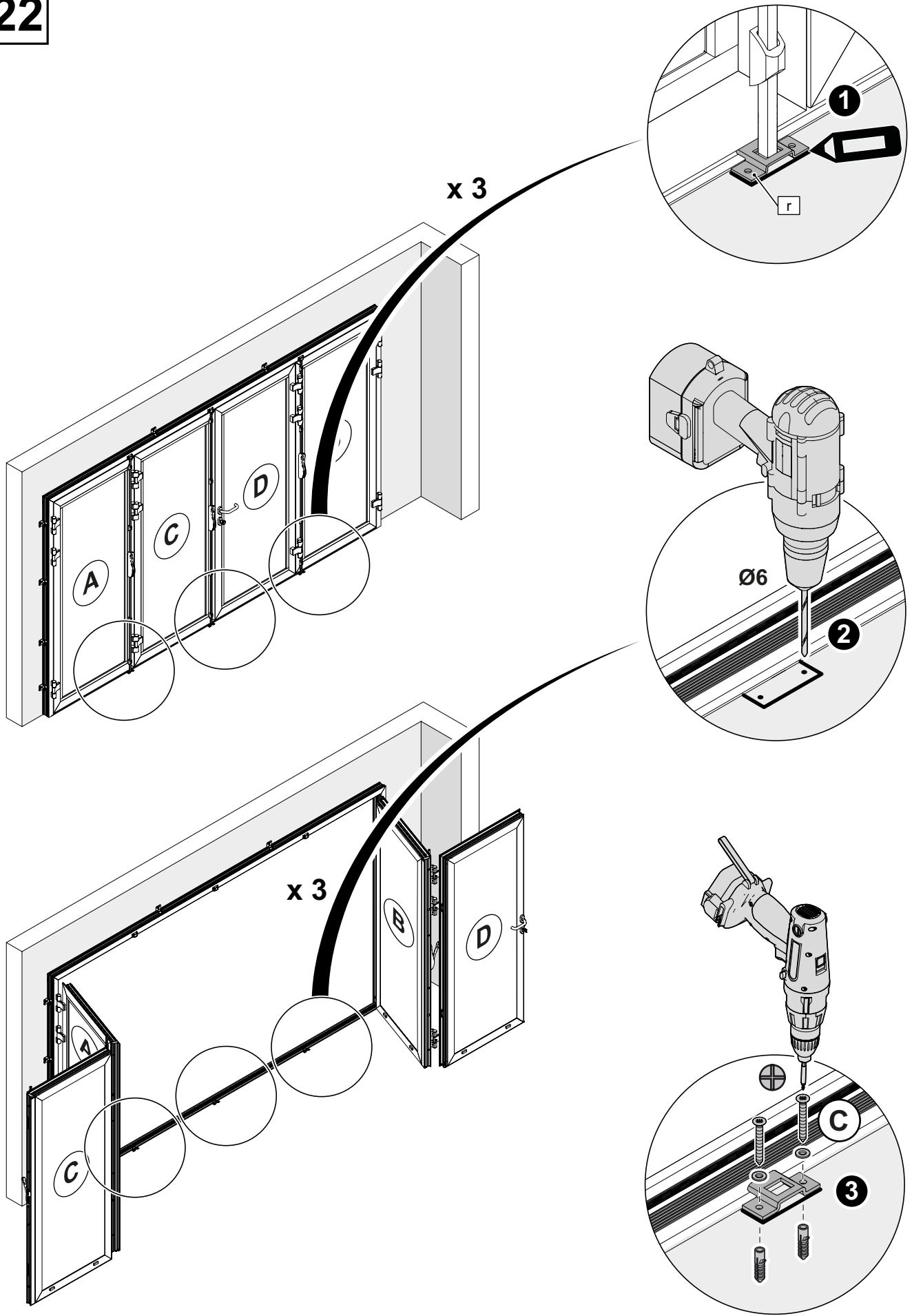



L'autre entrée principale



Adresses sur quefairedemesdechets.fr