

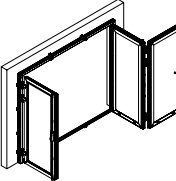

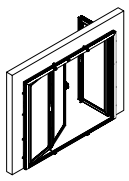

# Notice de pose porte 3 vantaux repliement journalier centré

## Einbauanleitung 3-flügelige Tür zentrierte Faltung

### Installation instructions for 3-leaf door, centred daily folding

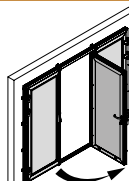
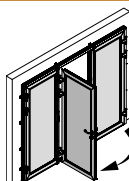

<b>Ouverture</b> <i>Öffnungsrichtung</i> <b>Opening</b>	Intérieure <i>Nach Innen</i> <i>To the inside</i>	Extérieure <i>Nach Außen</i> <i>To the outside</i>
	 <b>I</b>	 <b>E</b>
<b>Pose</b> <i>Montage Anschlag</i> <b>Mounting stop</b>	Tunnel <i>In der Öffnung</i> <i>Build in</i>	Applique <i>Hinter der Öffnung</i> <i>Build on</i>
	 <b>T</b>	 <b>A</b>
<b>Tirant</b> <i>Richtung Innen</i> <b>Pulling direction</b>	Droite <i>Rechts</i> <i>Right</i>	Gauche <i>Links</i> <i>Left</i>
	 <b>D</b>	 <b>G</b>
<b>Configuration / Konfiguration / Configuration :</b>		
<input type="checkbox"/> <input type="checkbox"/> <input type="checkbox"/> →  <b>Pages / Seiten / Pages 2-3</b>		

Option / Option / Variante	Oui / Ja / Yes	Non / Nein / No
Arrêt de porte à visser <i>Screw-on door stop</i> <i>Türfeststeller zum Anschrauben</i>	<input type="checkbox"/>	<input type="checkbox"/>
Arrêt de porte à sceller <i>Door stop to seal</i> <i>Türfeststeller zum Versiegeln</i>	<input type="checkbox"/>	<input type="checkbox"/>

**IAD**

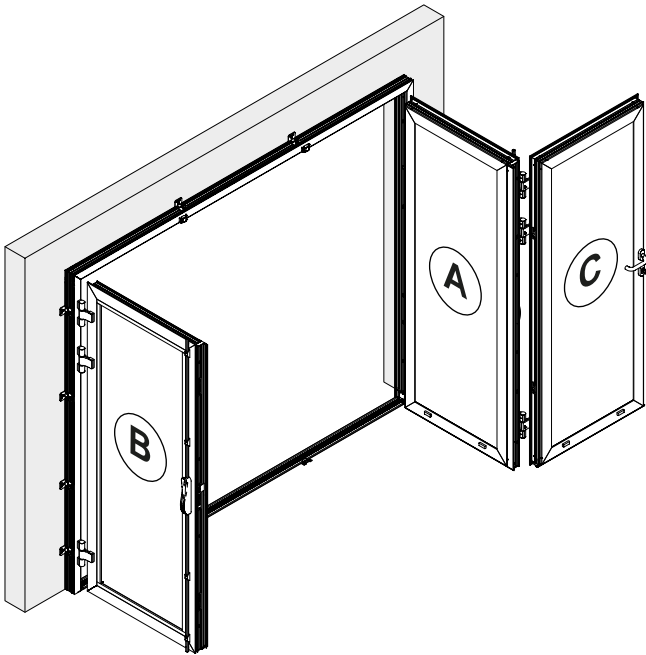

**ITD**

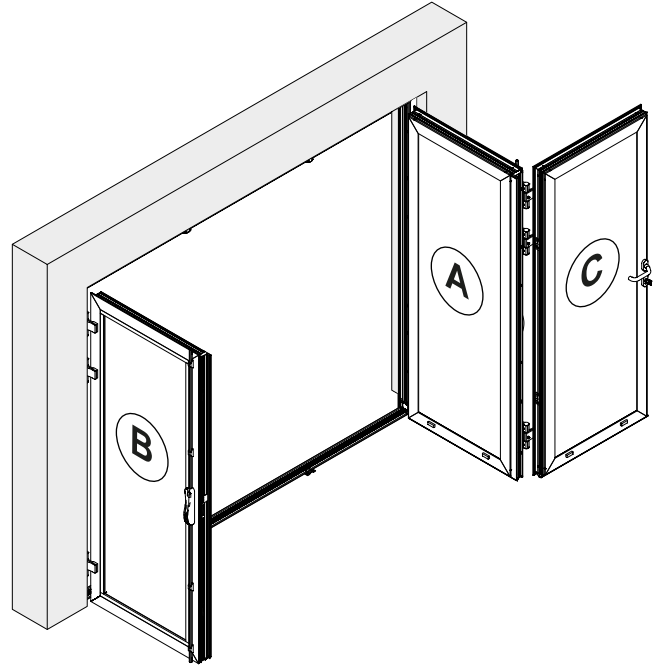

**IAG**

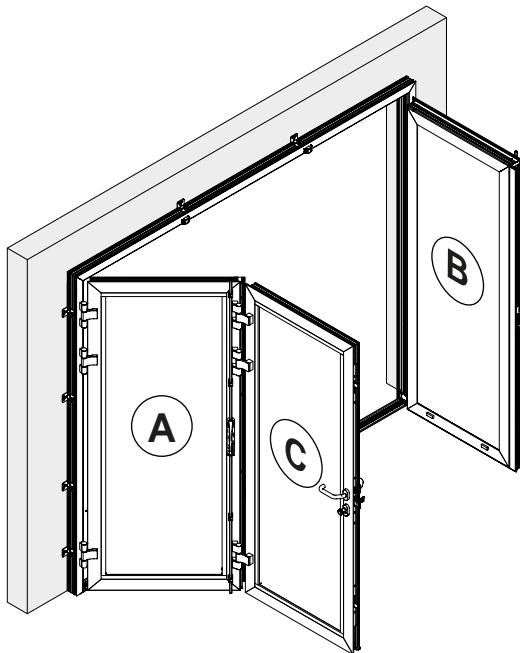

**ITG**

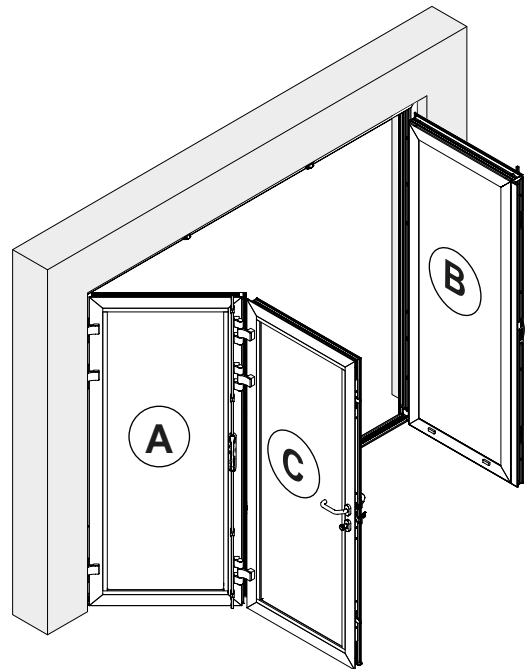

**EAD**

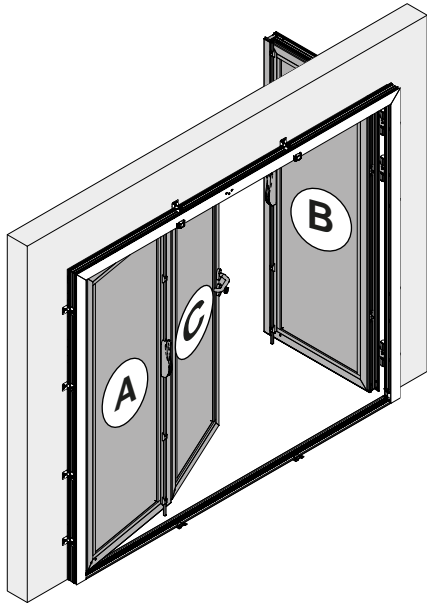

**ETD**

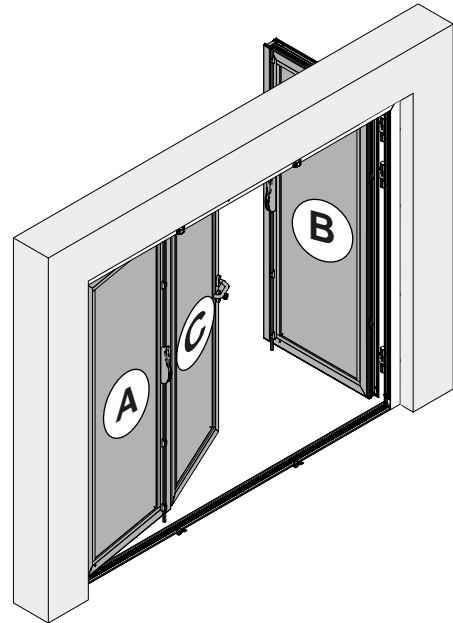



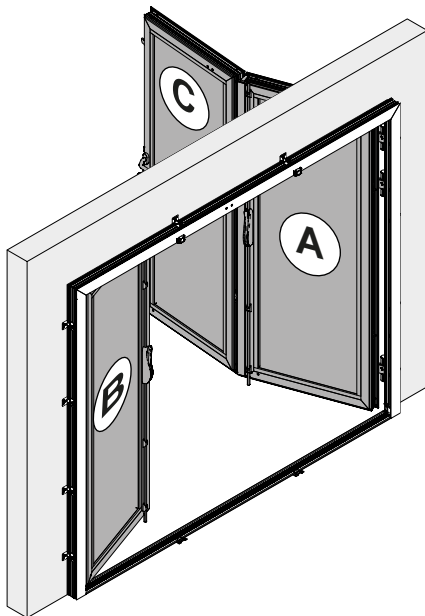



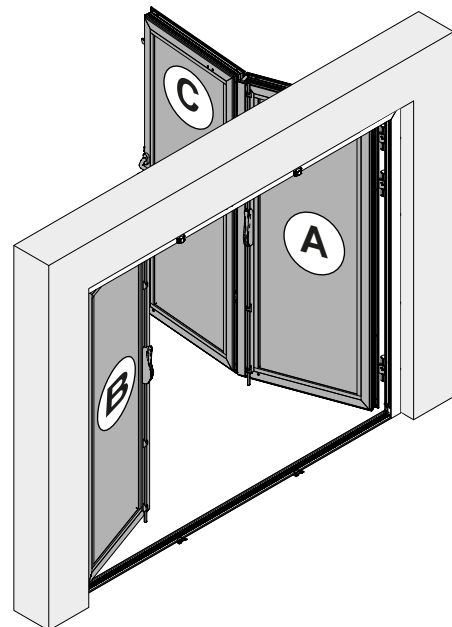

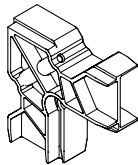
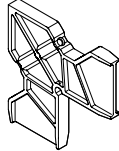
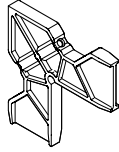

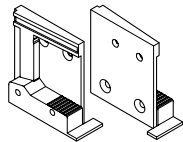
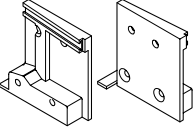

**EAG**

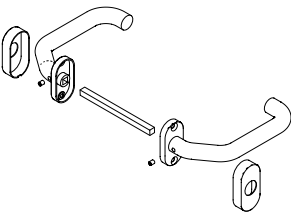

**ETG**

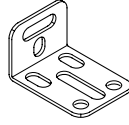
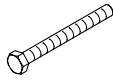

Pièces fournies / Parts supplied / Gelieferte Teile			
<b>a</b>			<b>x2</b>
<b>b</b>		Si ouverture intérieure If inside opening Bei Öffnung nach innen	<b>x2</b>
<b>c</b>		Si ouverture extérieure If outside opening Bei Öffnung nachaußen	<b>x2</b>
<b>d</b>			<b>x8</b>
<b>e</b>	 M5 x 25		<b>x8</b>
<b>f</b>		Si ouverture intérieure If inside opening Bei Öffnung nach innen	<b>x2</b>
<b>g</b>		Si ouverture extérieure If outside opening Bei Öffnung nachaußen	<b>x2</b>
<b>h</b>			<b>x2</b>
<b>i</b>	 M4,2 x 32		<b>x4</b>
<b>l</b>			<b>x18</b>
<b>m</b>			<b>x9</b>
<b>n</b>			<b>x5</b>
<b>p</b>	 M4 x 16		<b>x8</b>
<b>q</b>			<b>x1</b>
<b>r</b>			<b>x2</b>

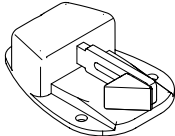
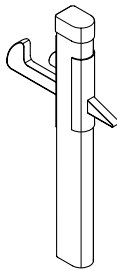
Pièces fournies / Parts supplied / Gelieferte Teile			
<b>s</b>			<b>x10</b>
<b>t</b>		Si fixation applique If build in Bei Option hinter der Öffnung	<b>x10</b>
<b>u</b>	 M8 x 80	Si fixation applique If build in Bei Option hinter der Öffnung	<b>x8</b>
<b>v</b>	 M8	Si fixation applique If build in Bei Option hinter der Öffnung	<b>x10</b>
<b>w</b>	 M8 x 20	Si fixation applique If build in Bei Option hinter der Öffnung	<b>x2</b>
<b>aa</b>		Si option arrêt de porte à visser If screw-on door stop option Bei Option Türfeststeller zum Anschrauben	<b>x1</b>
<b>bb</b>		Si option arrêt de porte à sceller If door stop to seal option Bei Option Türstopper zum Versiegeln	<b>x1</b>
<b>hh</b>	<b>Notice de montage Installation instruction Montageanleitung</b>	<b>NFF16600_C</b>	<b>x1</b>



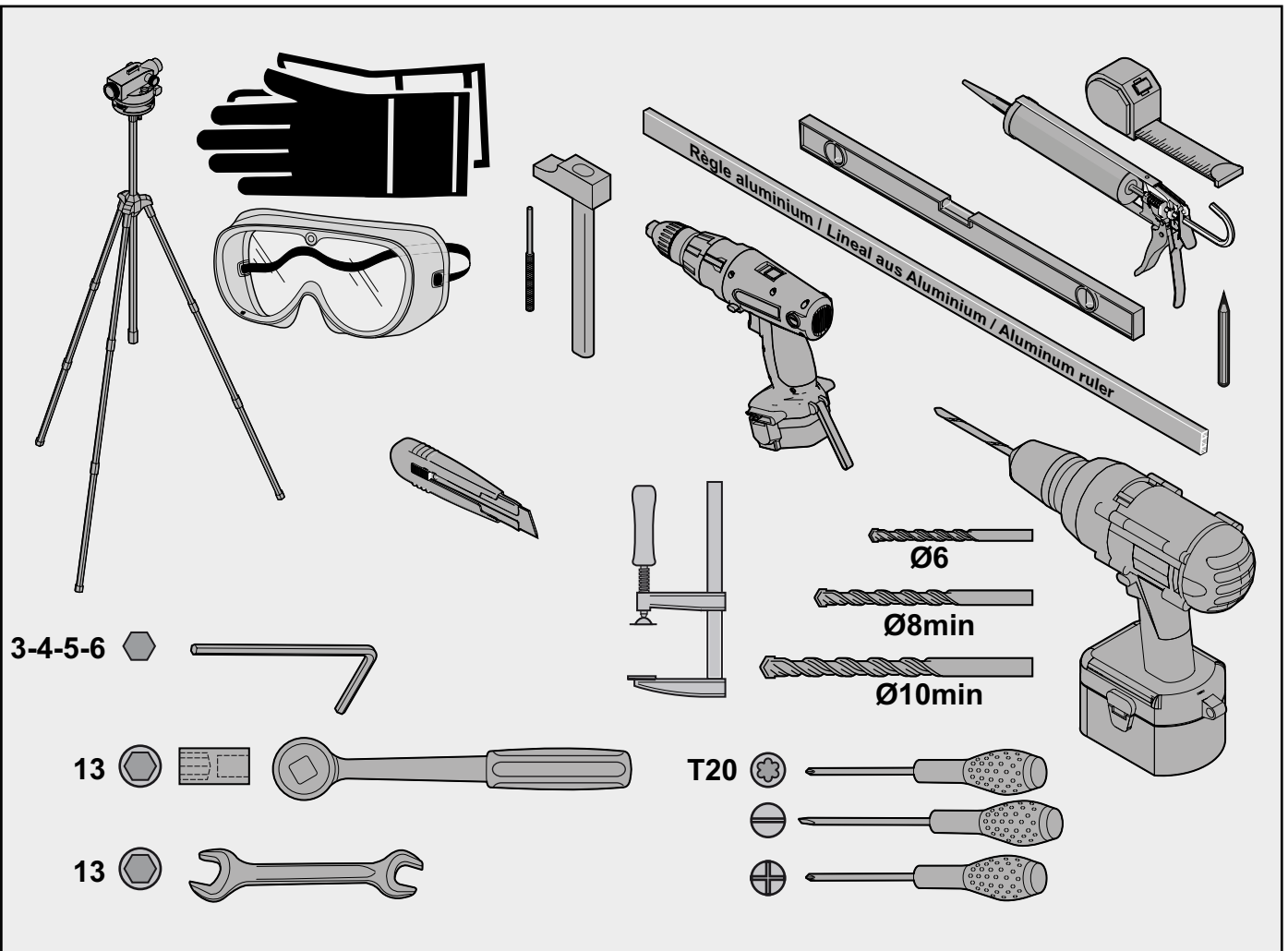





Conseillé, non fourni. À définir en fonction du support.  
*Empfohlen, nicht enthalten. Entsprechend der Förderungen zu definieren.*  
*Recommended, not provided. To be defined according to the support.*

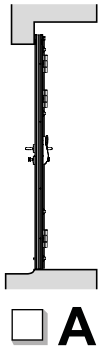

1

Applique  
Hinter der Öffnung  
Build on



-  (FR) Surfaces planes, de niveau et d'aplomb
-  (DE) Flächen müssen eben und lotrecht sein
-  (GB) Surfaces must be flat and plumb

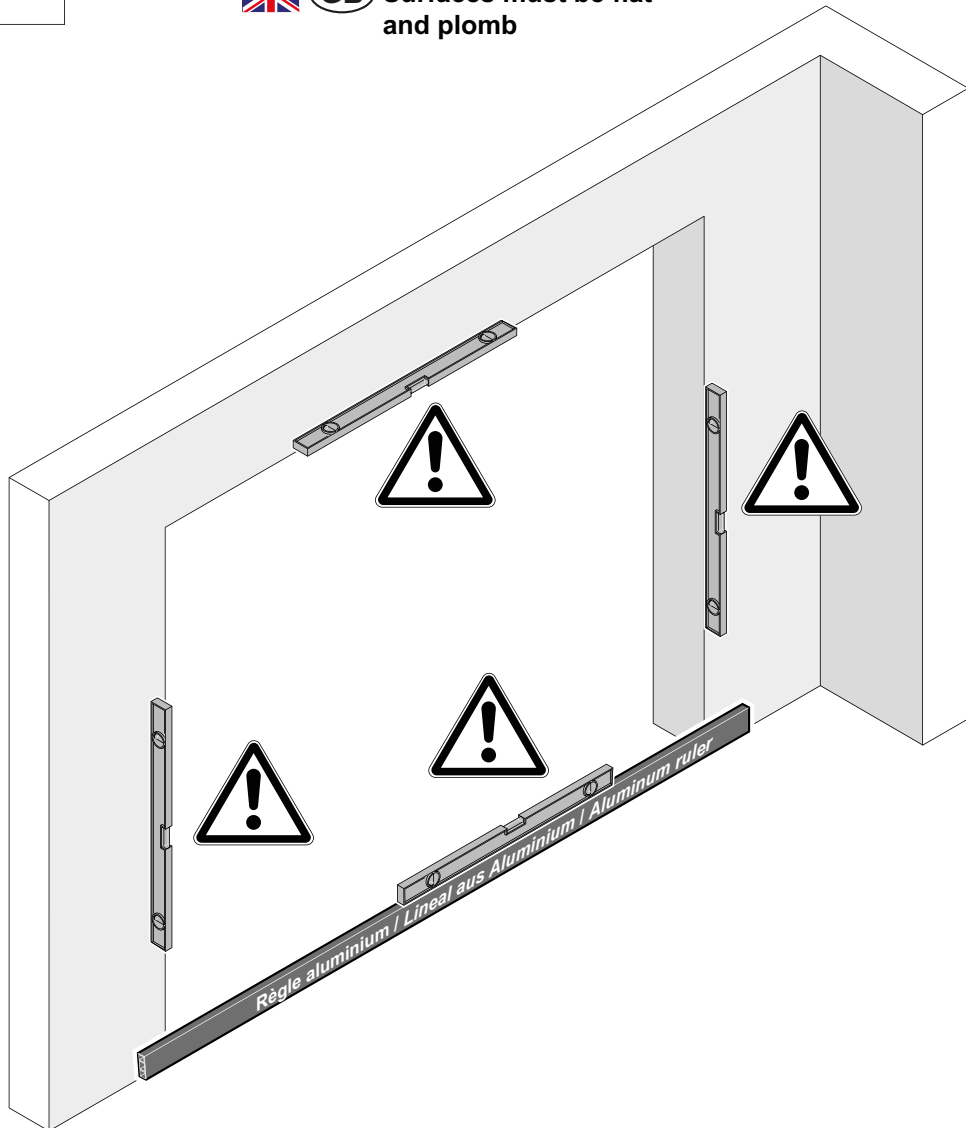

2

Tunnel  
In der Öffnung  
Build in

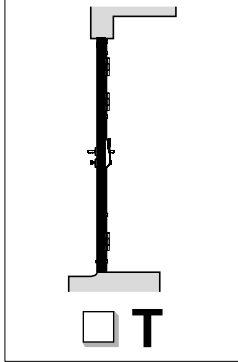

FR

Surfaces planes,  
de niveau et d'aplomb



DE

Flächen müssen eben  
und lotrecht sein



GB

Surfaces must be flat  
and plumb

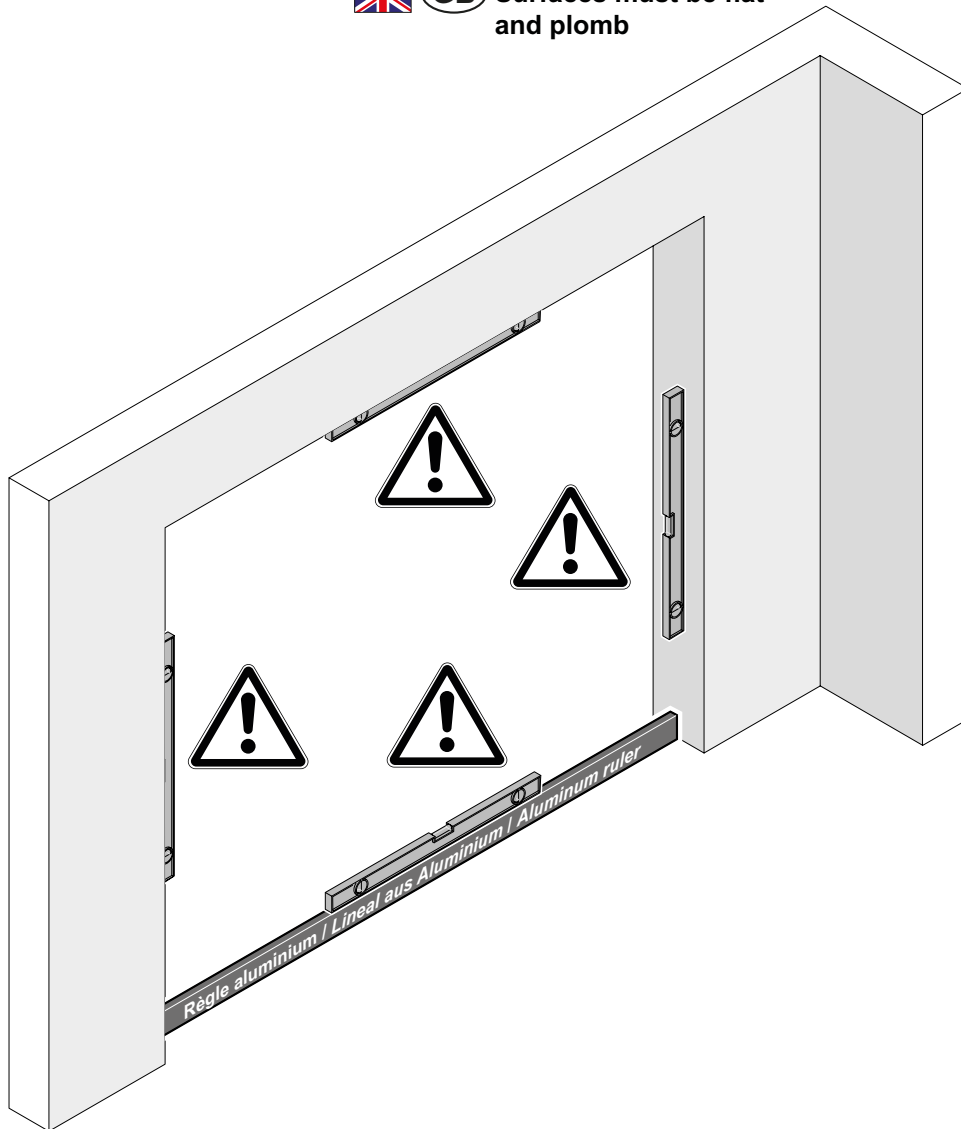

**3**

Applique  
Hinter der Öffnung  
Build on

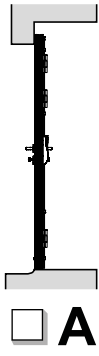

Extérieure  
Nach Außen  
To the outside

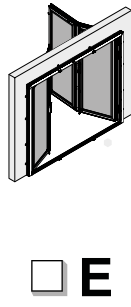

250 mm maximum

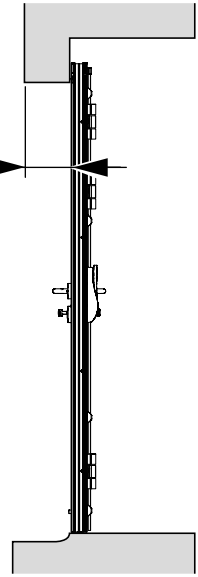

✓ OK

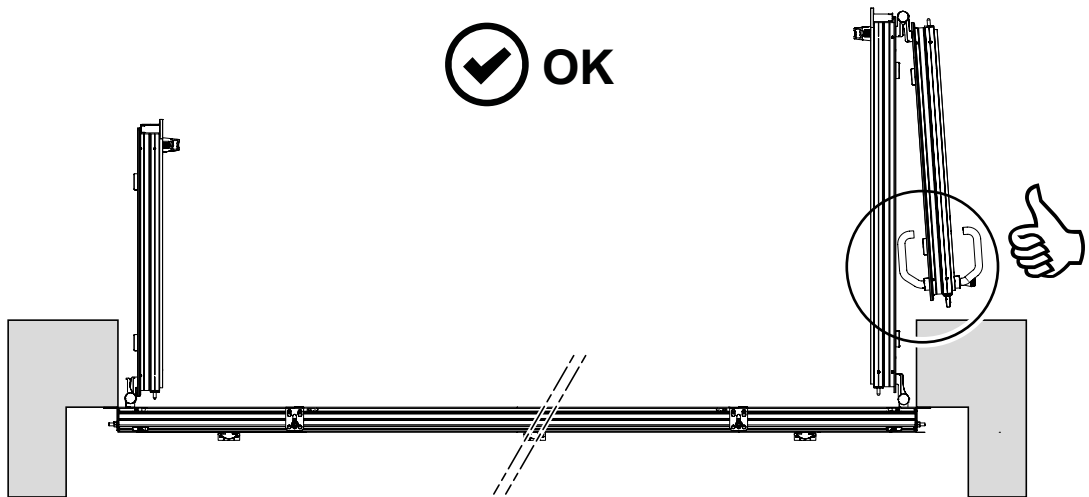

✗ NOK

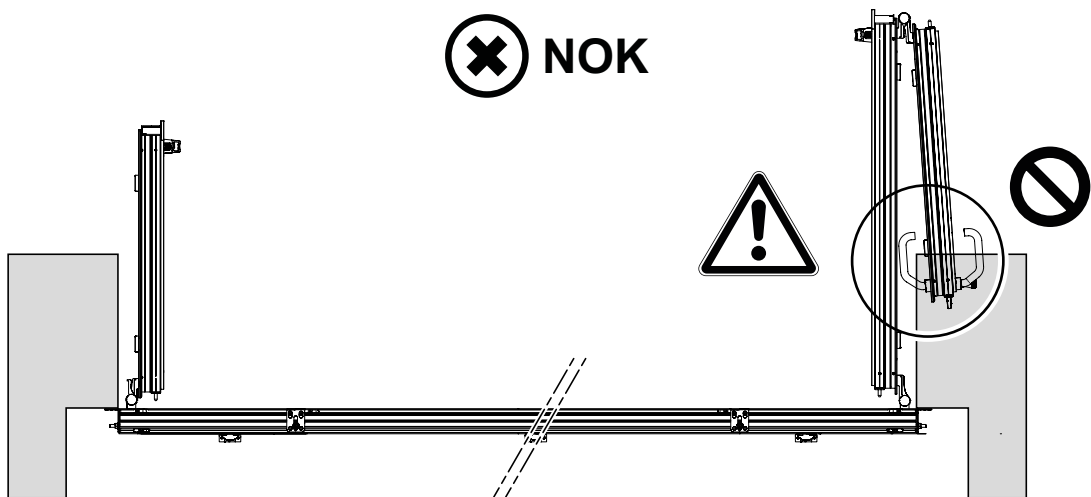



Tunnel  
In der Öffnung  
Build in

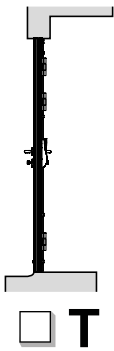

Extérieure  
Nach Außen  
To the outside

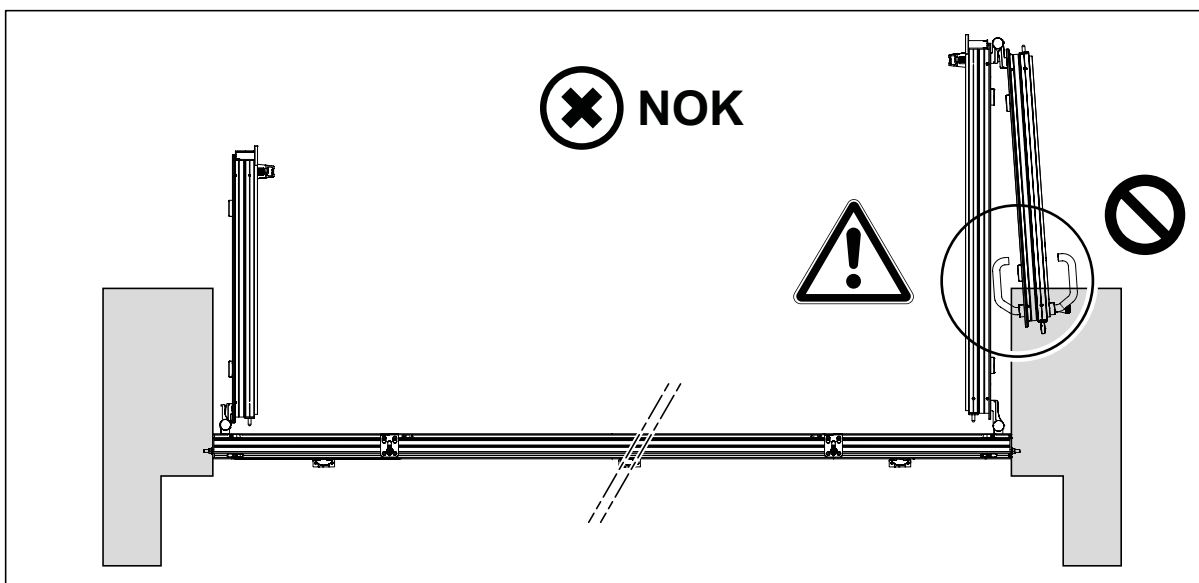
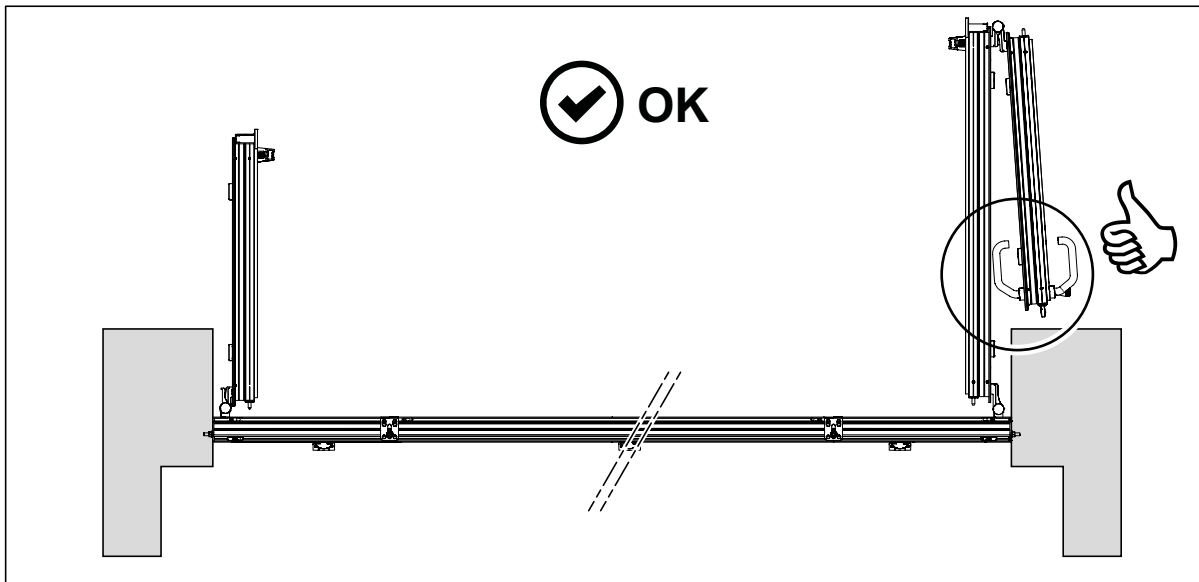
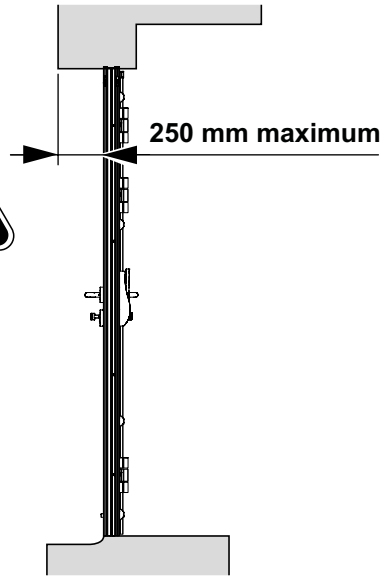
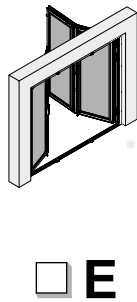

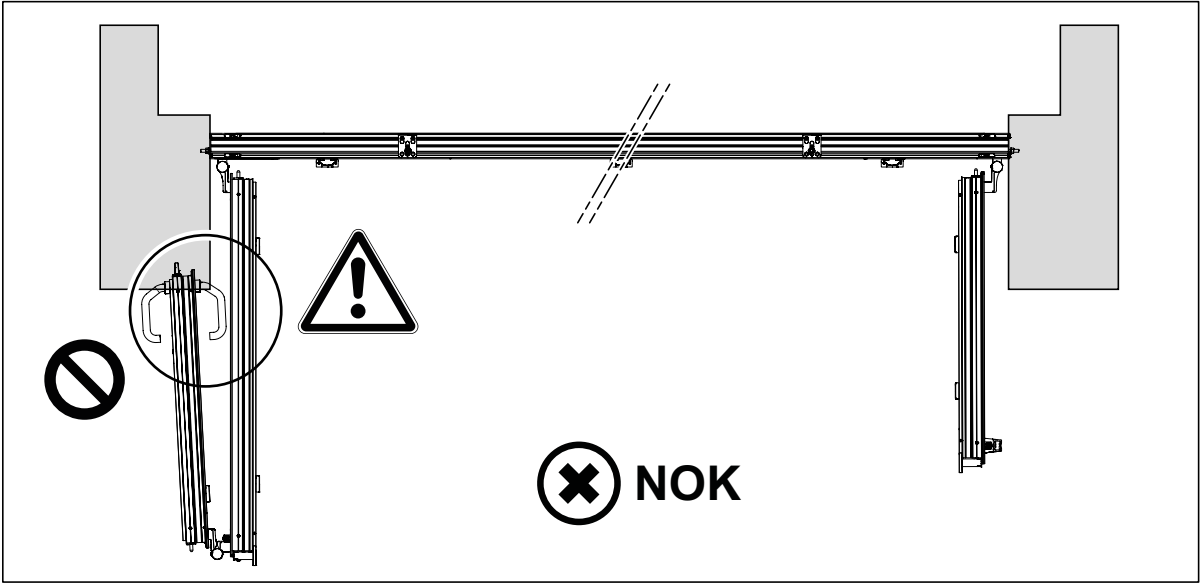
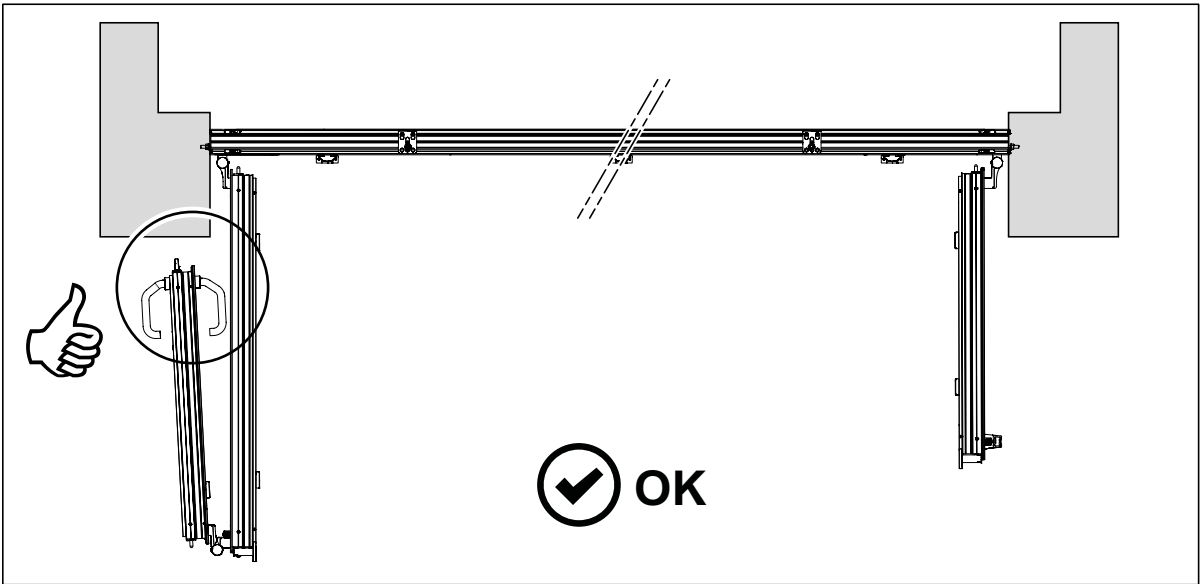
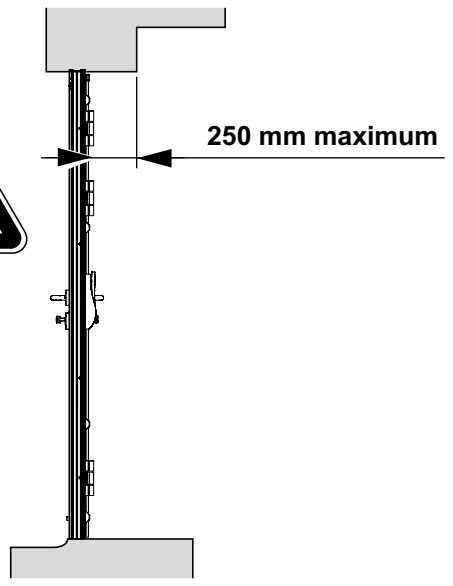
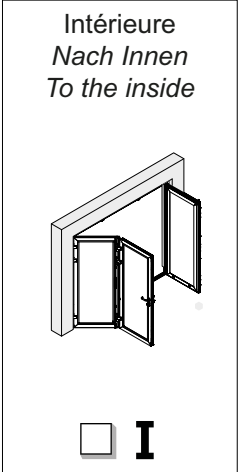
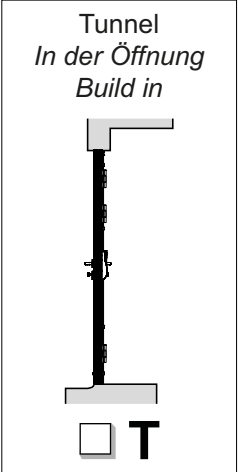

**4**

Applique  
Hinter der Öffnung  
Build on

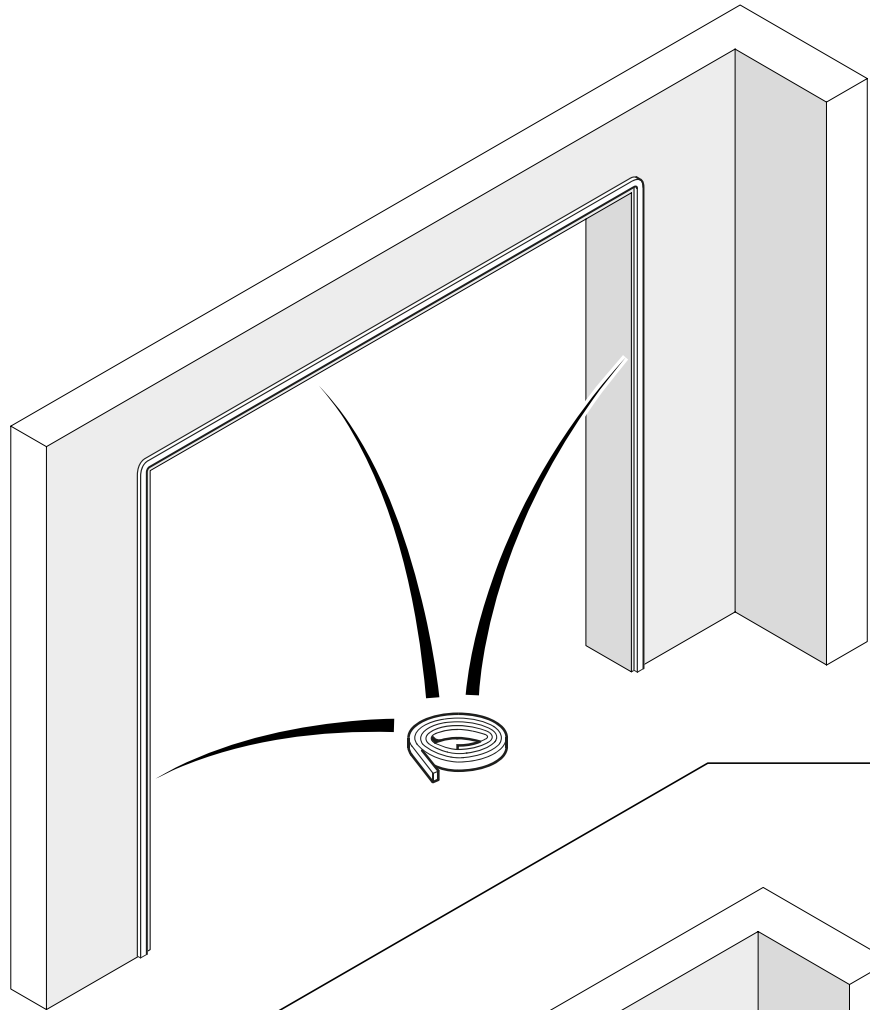
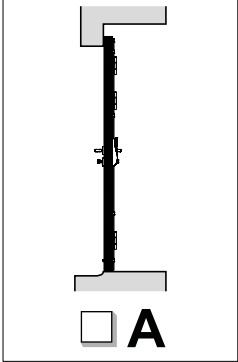

Tunnel  
In der Öffnung  
Build in

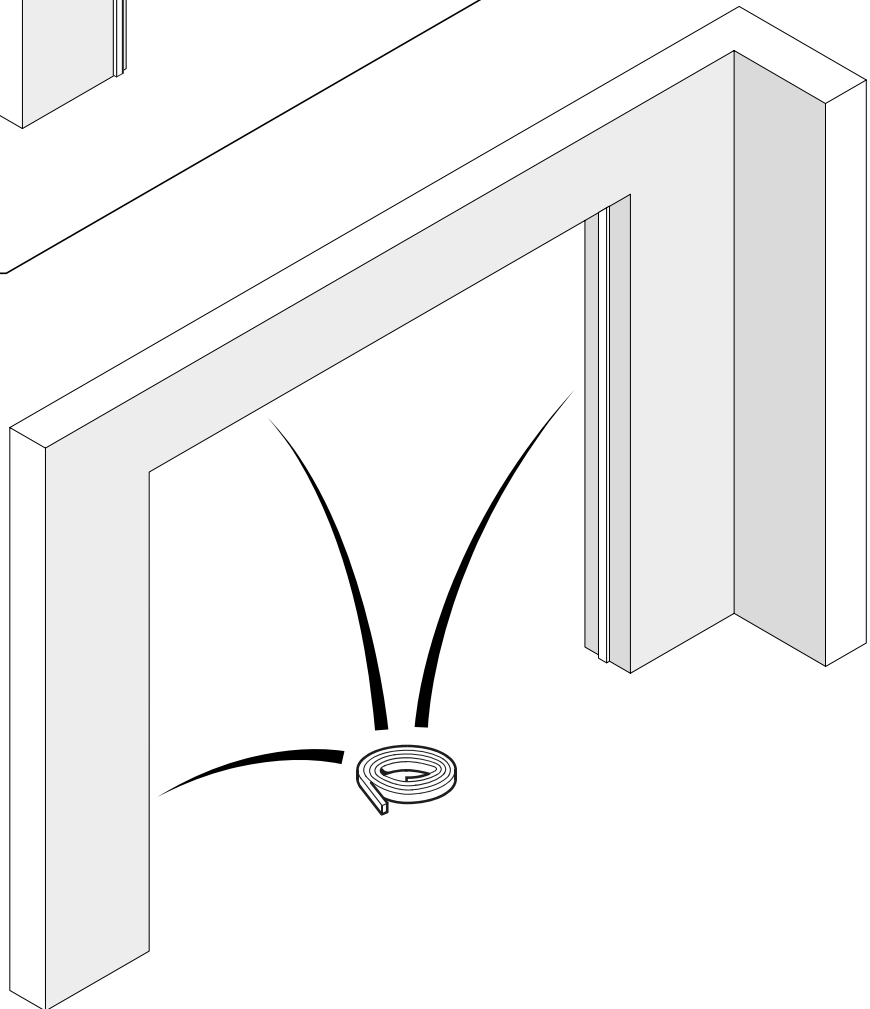
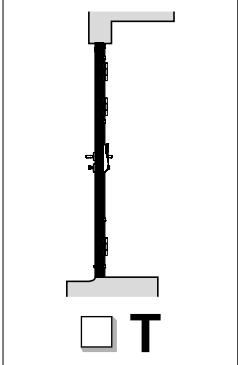

5

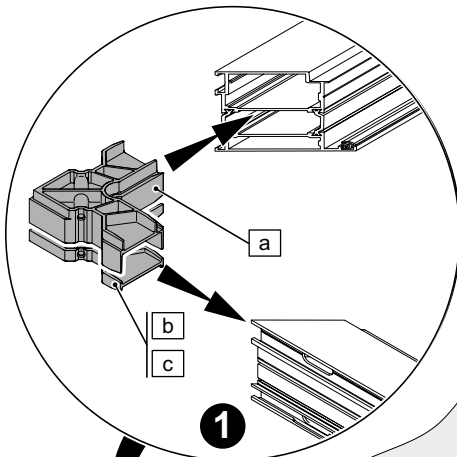
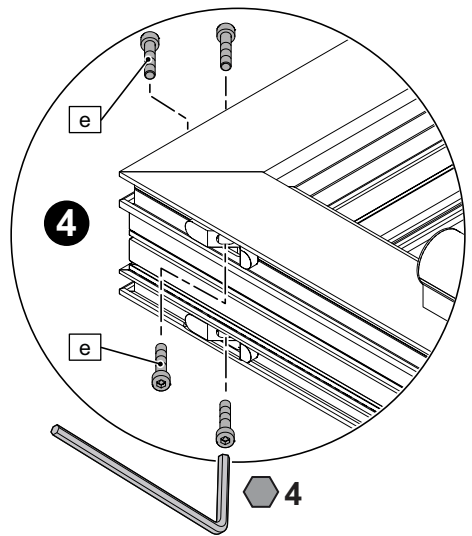
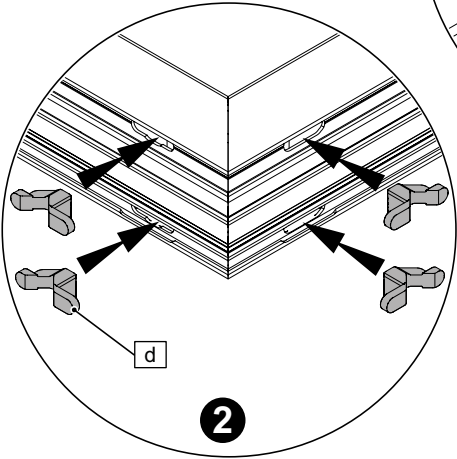
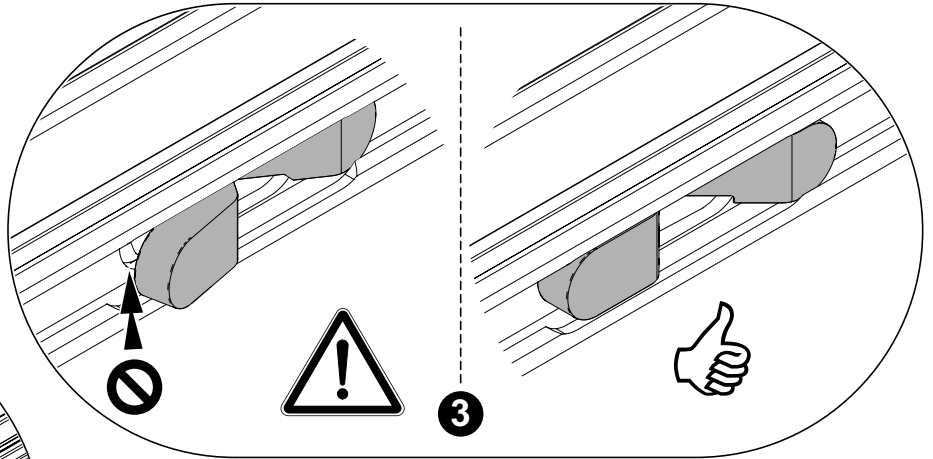

x 2

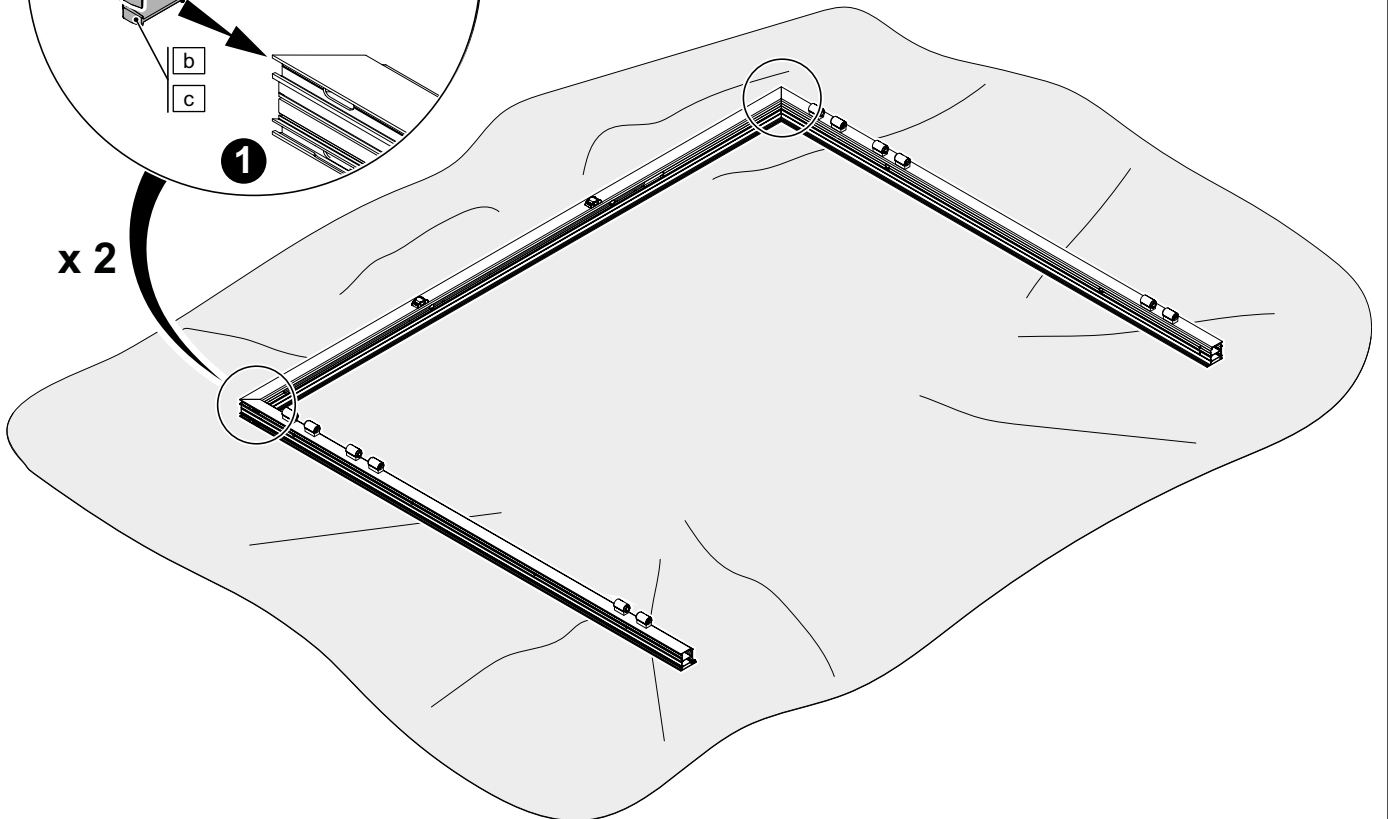

**6**

Intérieure  
Nach Innen  
To the inside

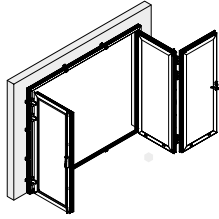

□ **I**

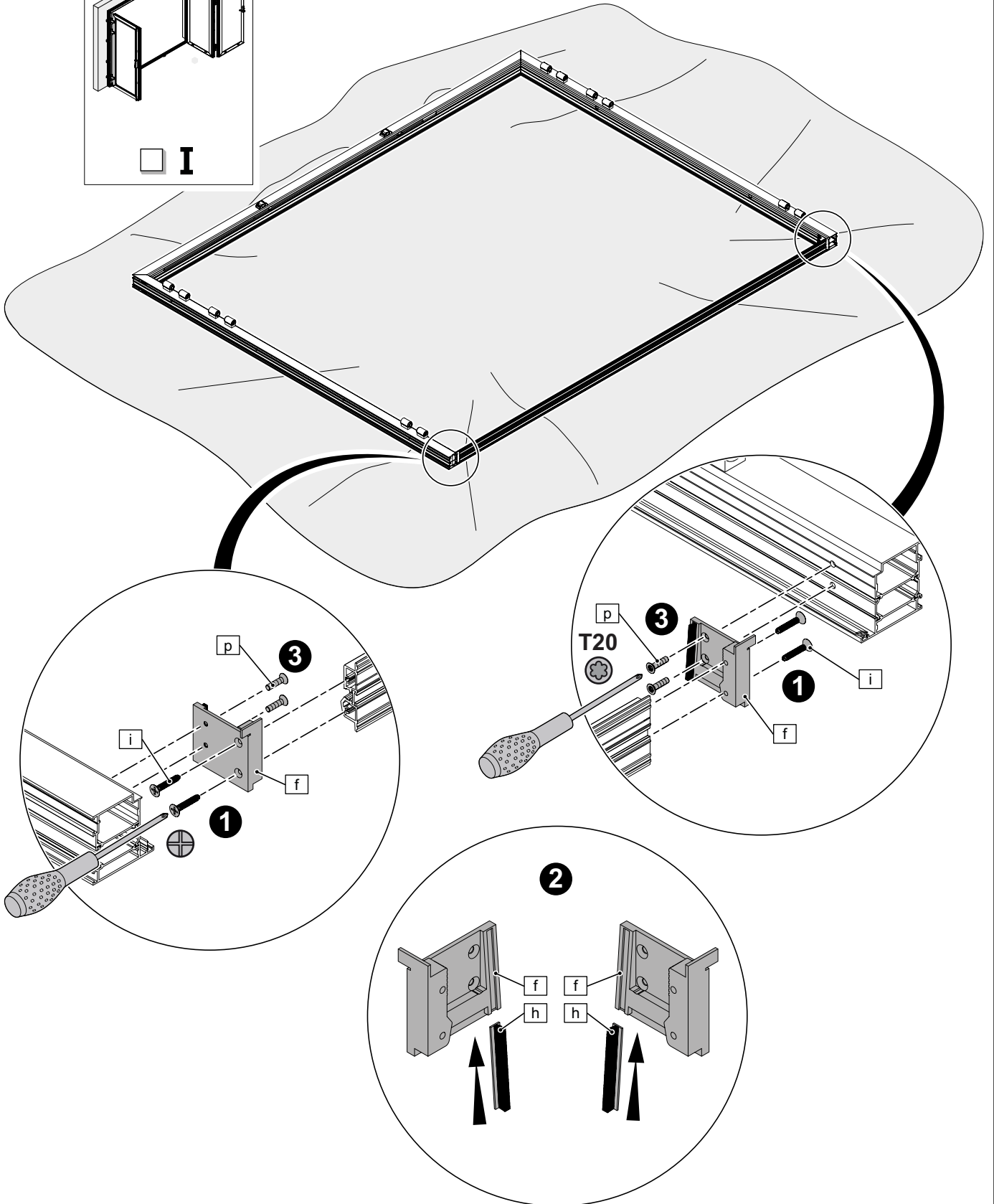

7

Extérieure  
Nach Außen  
To the outside

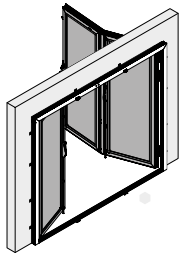

□ E

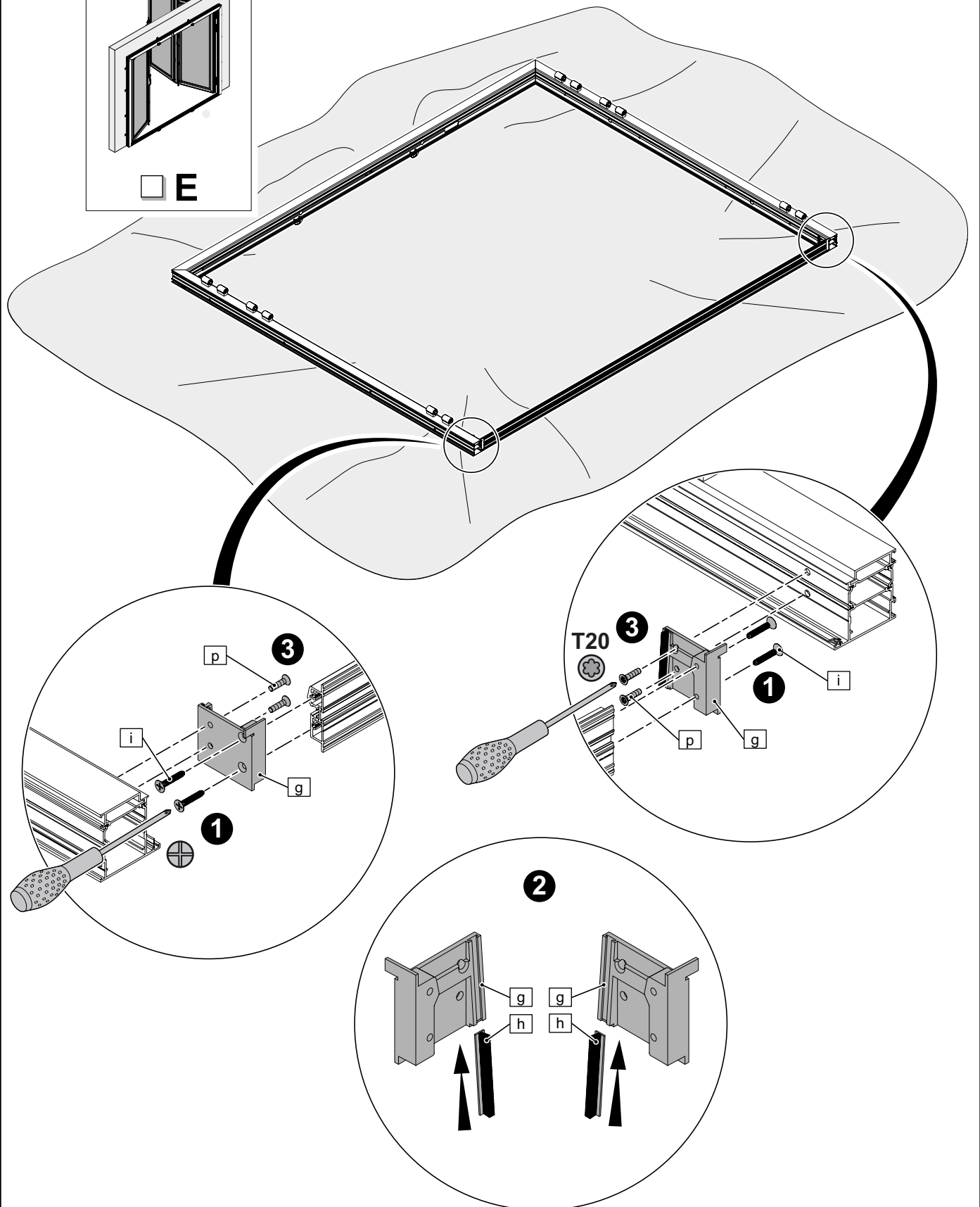

8

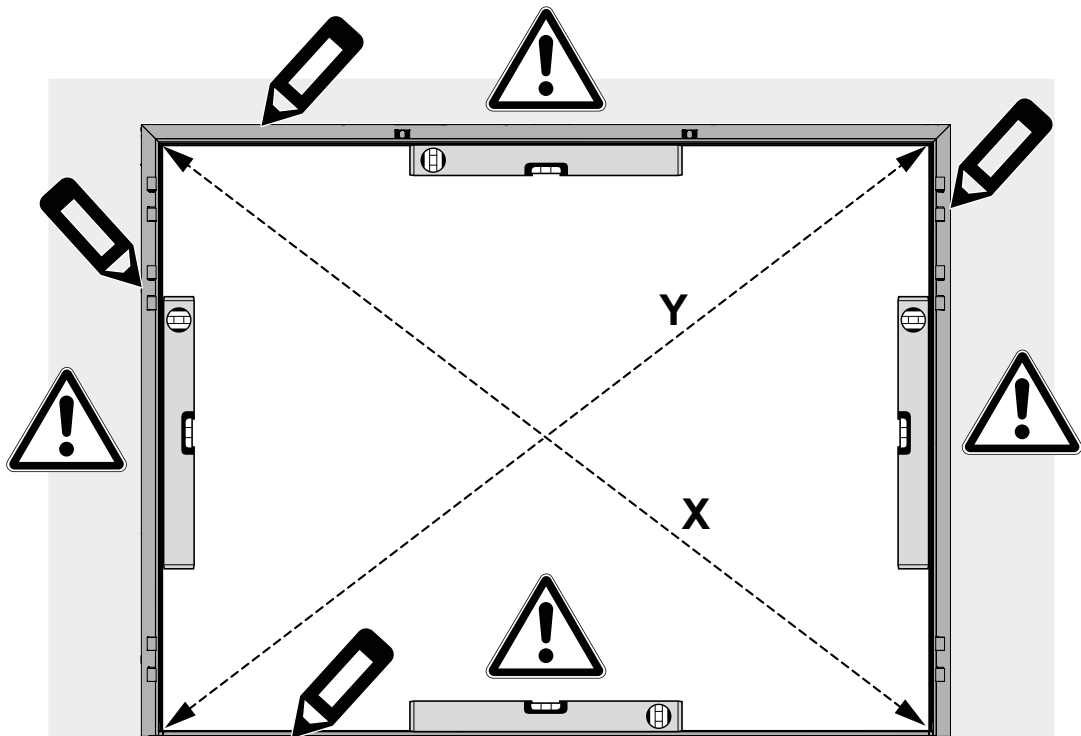

**09**

Applique  
Hinter der Öffnung  
Build on

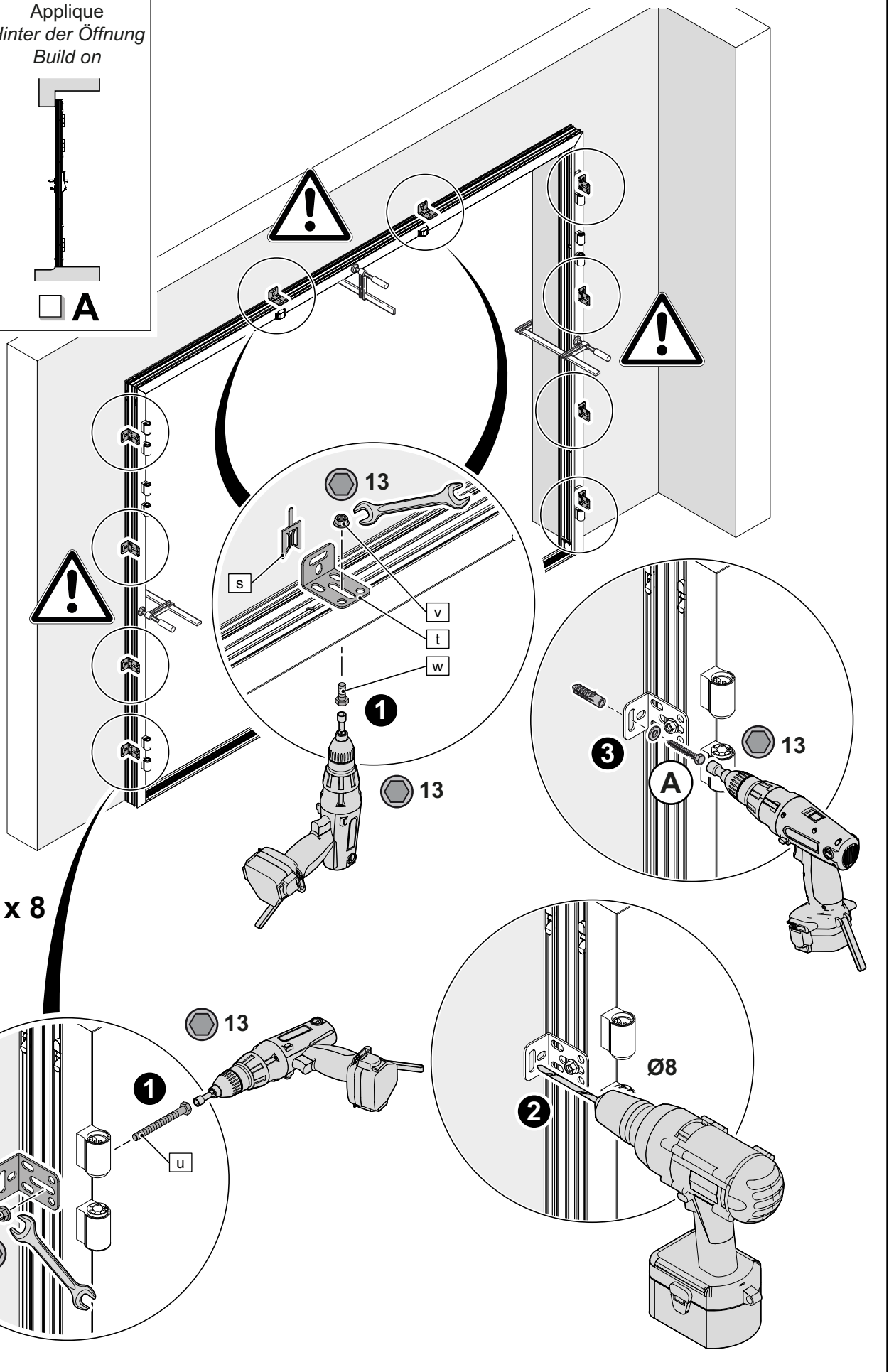
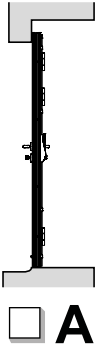



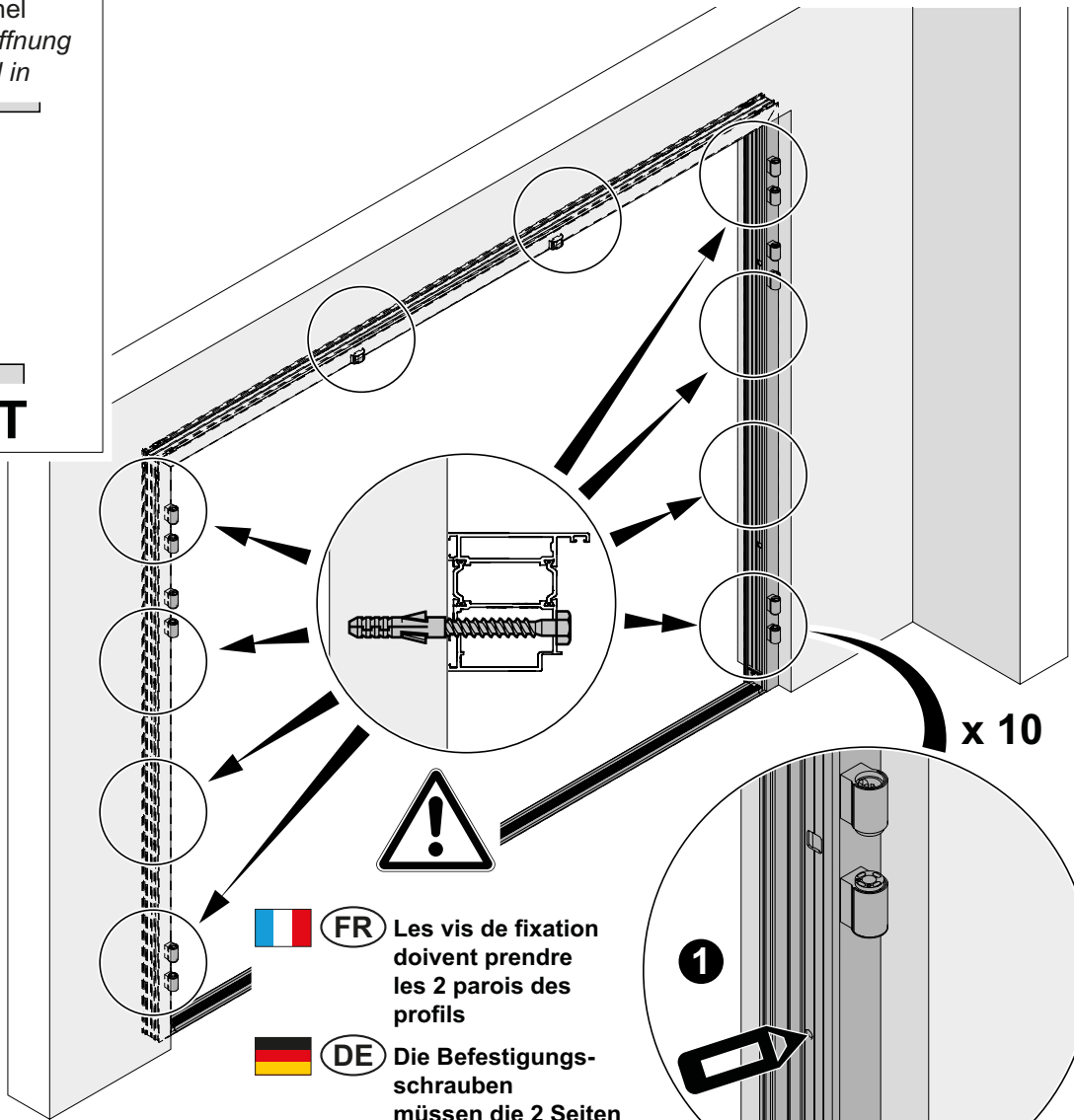
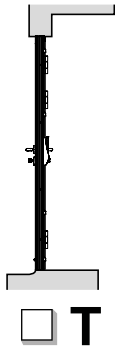

**10**

Tunnel  
In der Öffnung  
Build in



 **FR** Les vis de fixation doivent prendre les 2 parois des profils

 **DE** Die Befestigungsschrauben müssen die 2 Seiten des Profils greifen

 **GB** The fixing screws must take the 2 walls of the profiles

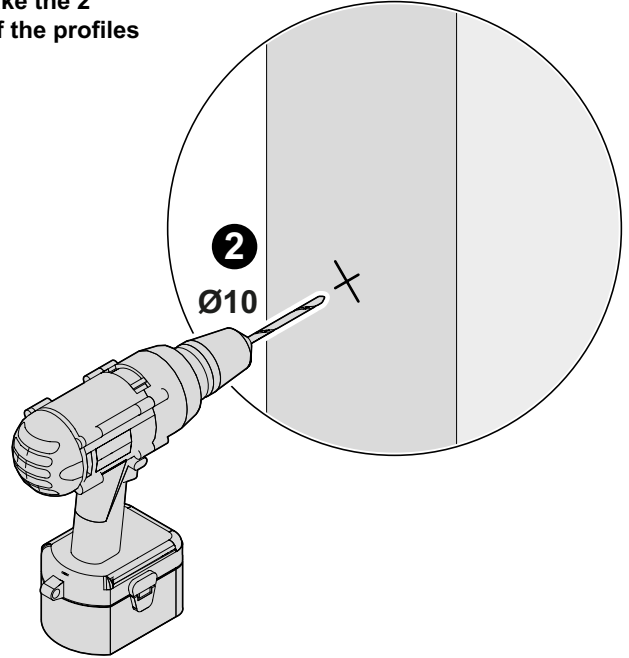
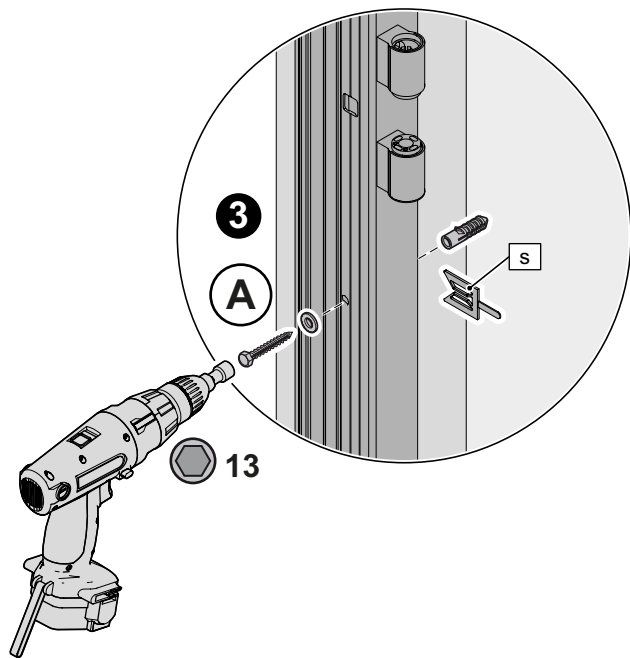

11

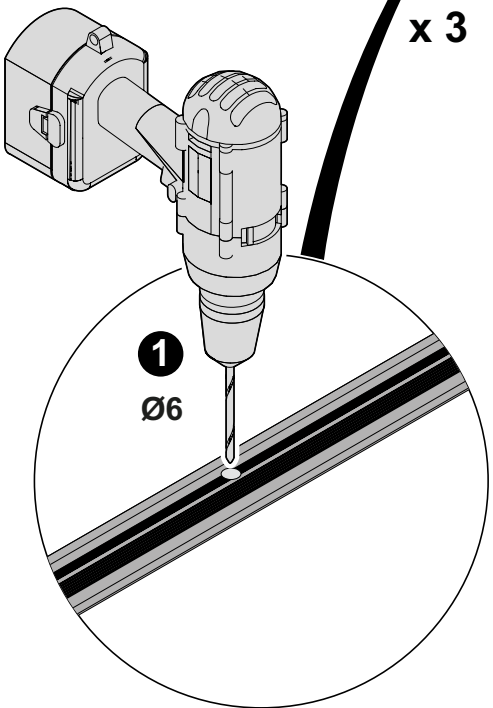
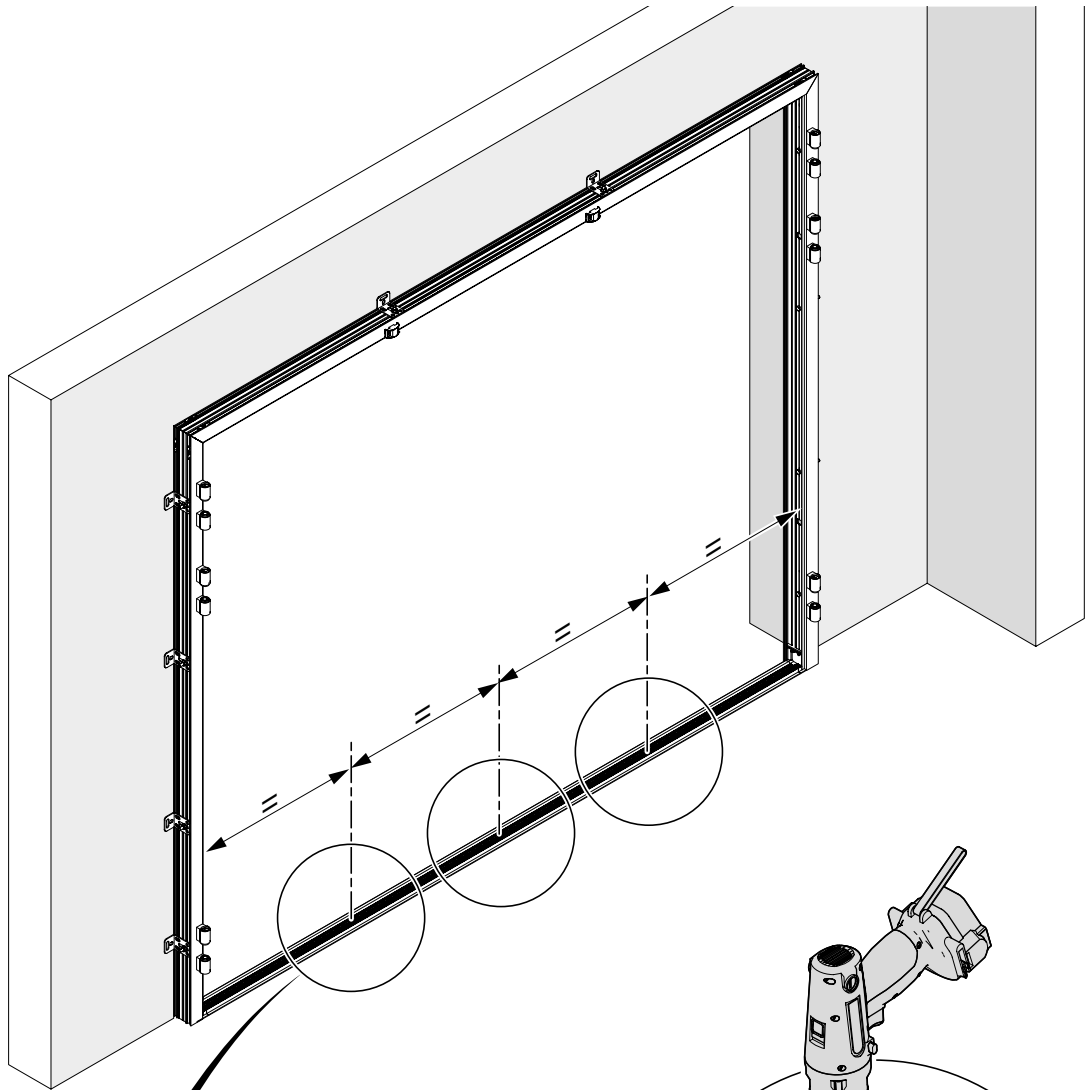

x 3

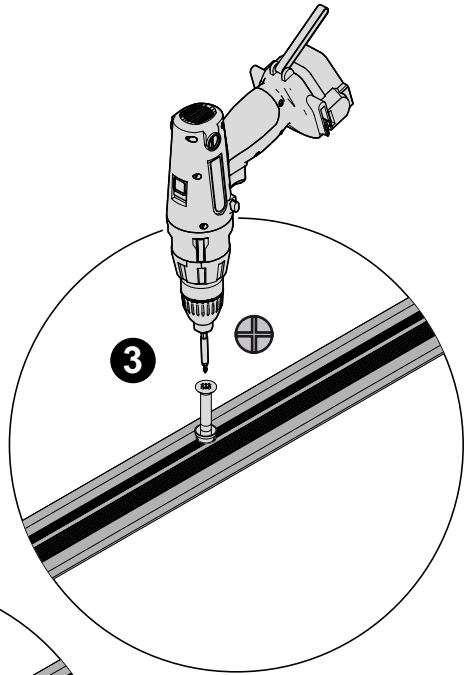
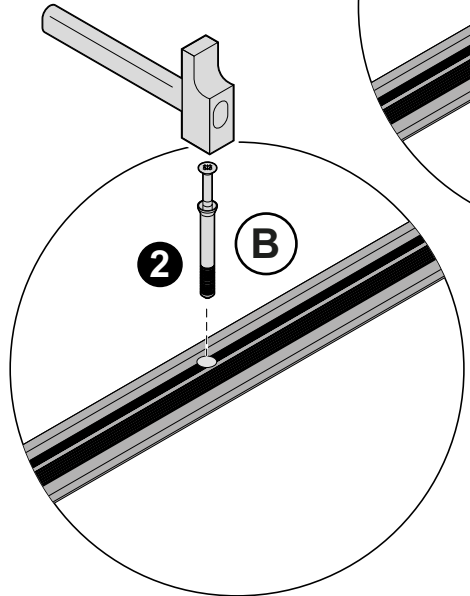

12

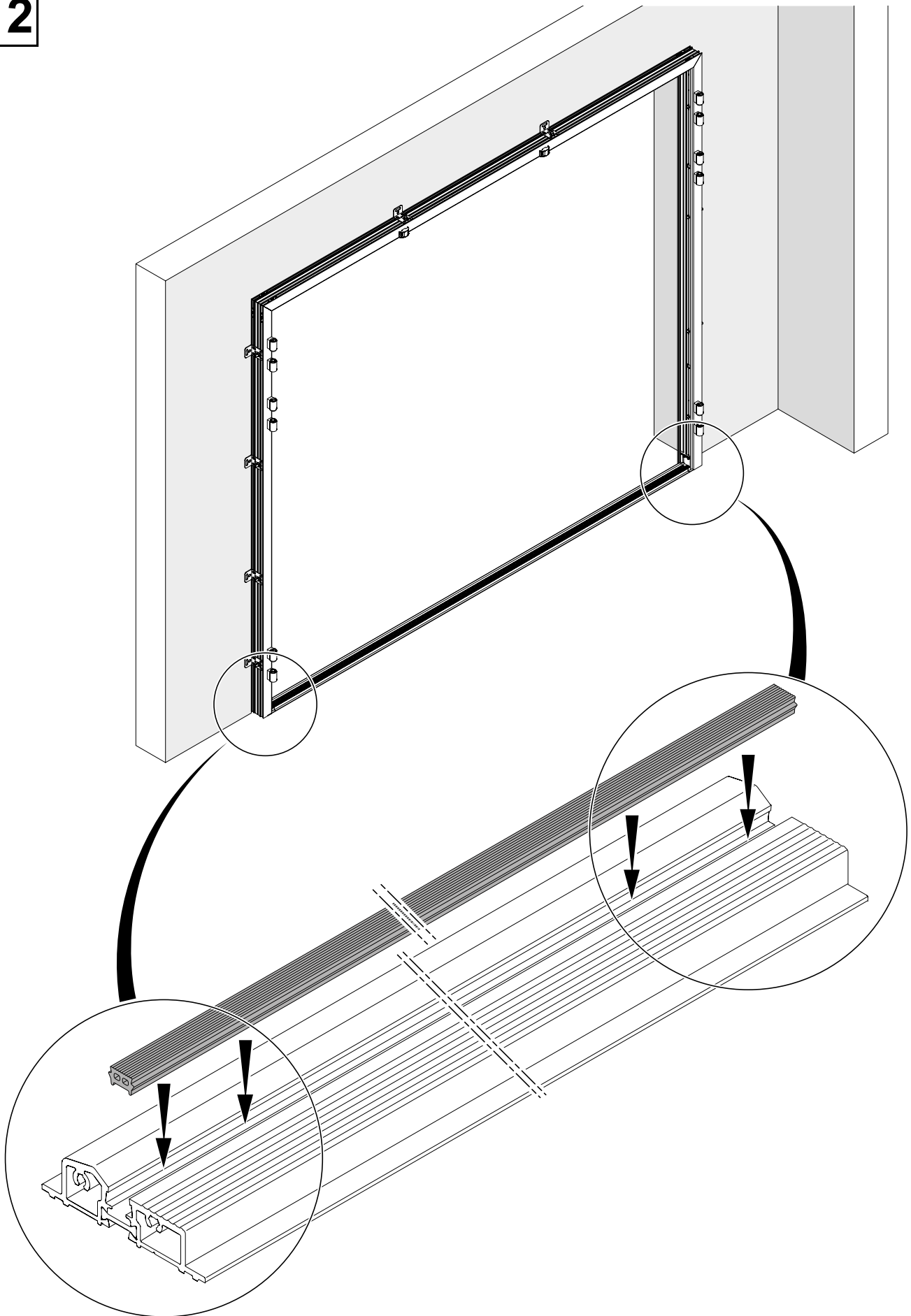

13

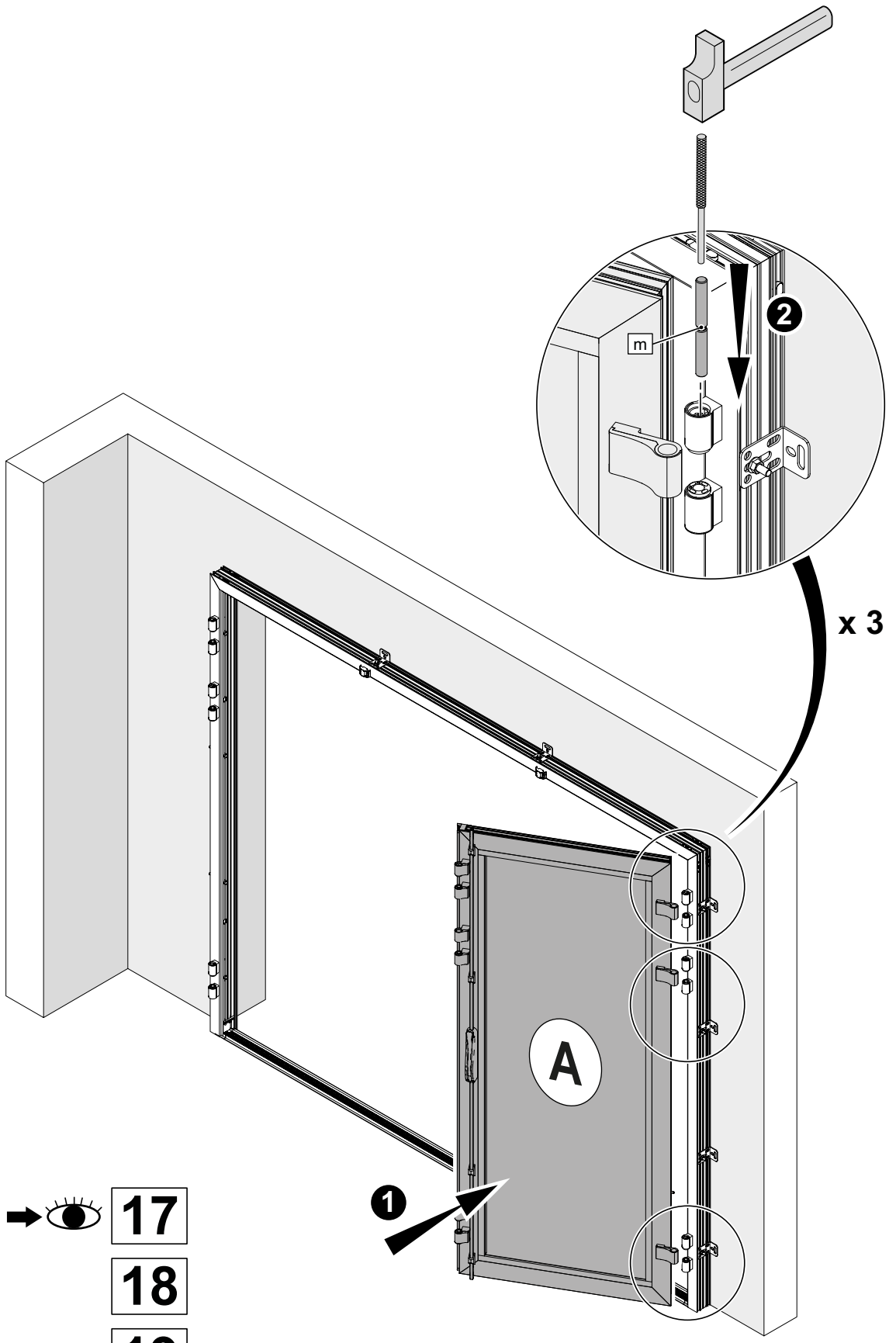

14

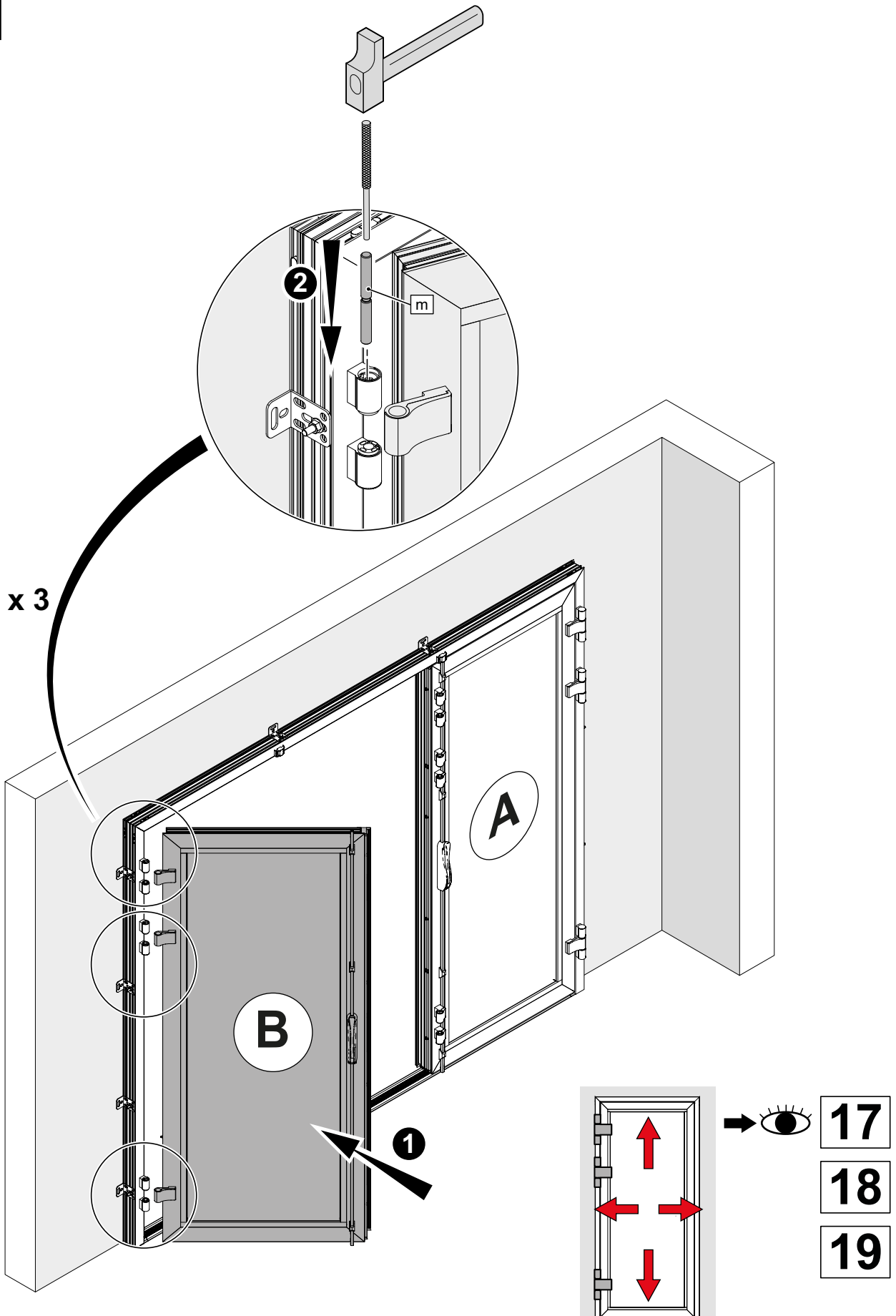

15

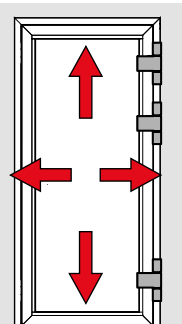
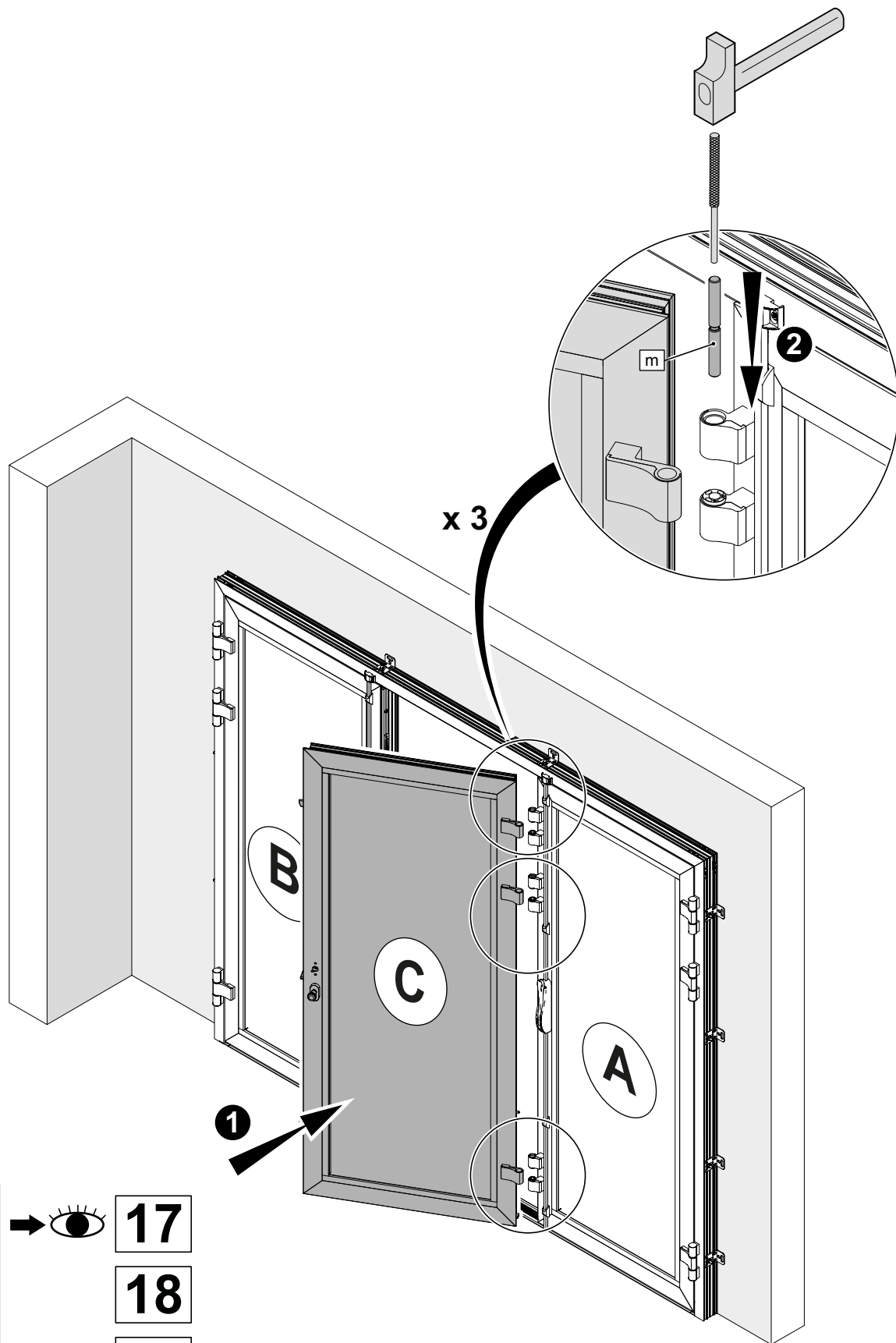

16

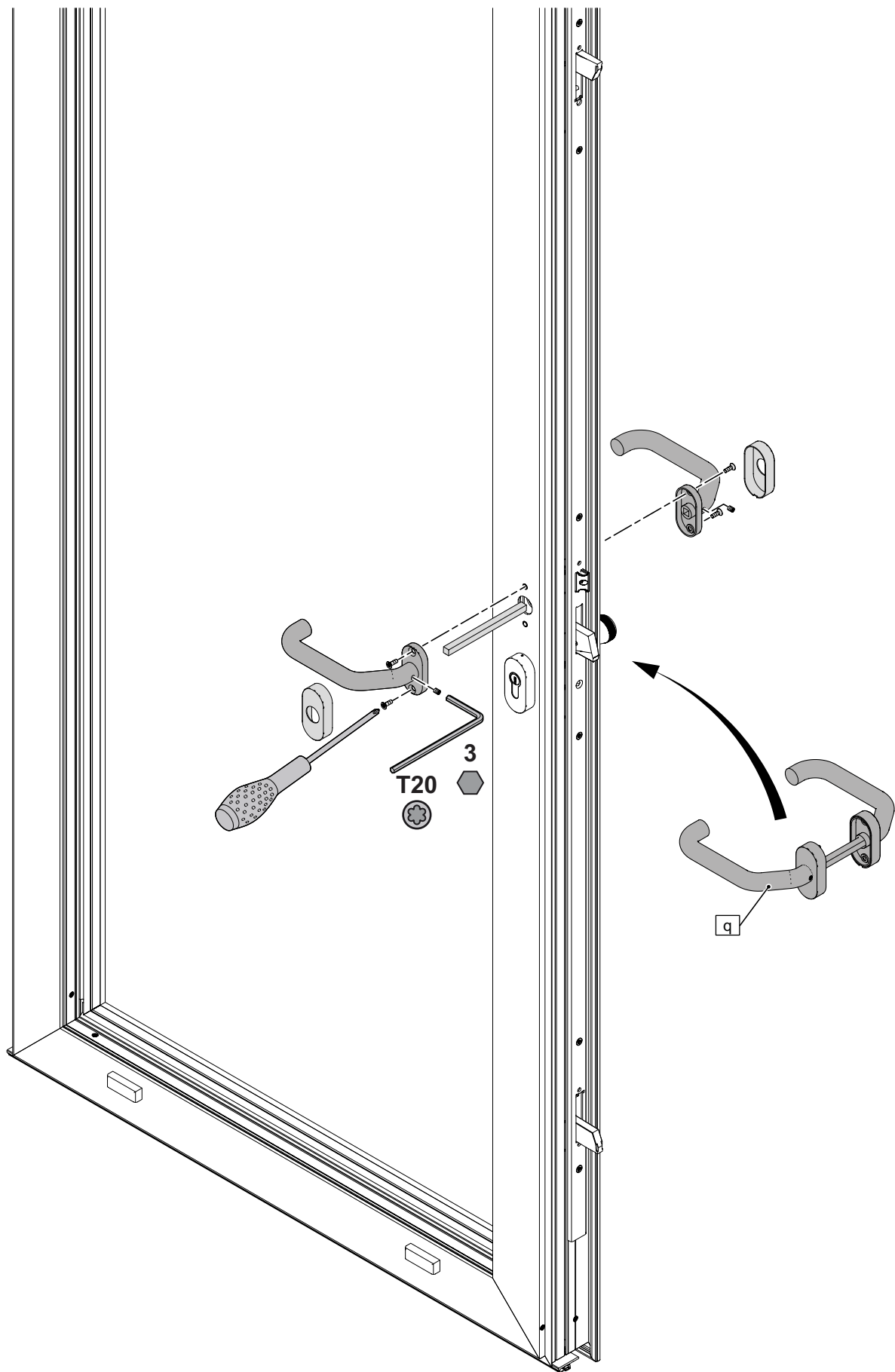

17

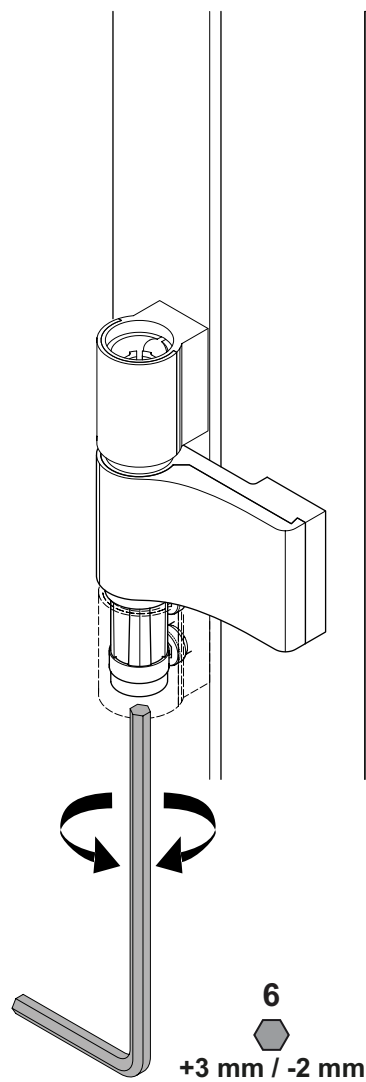
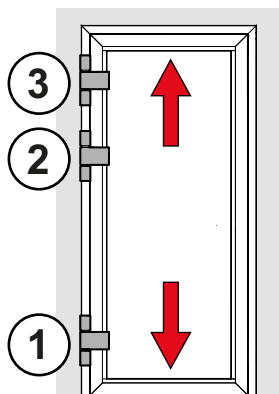



# 18

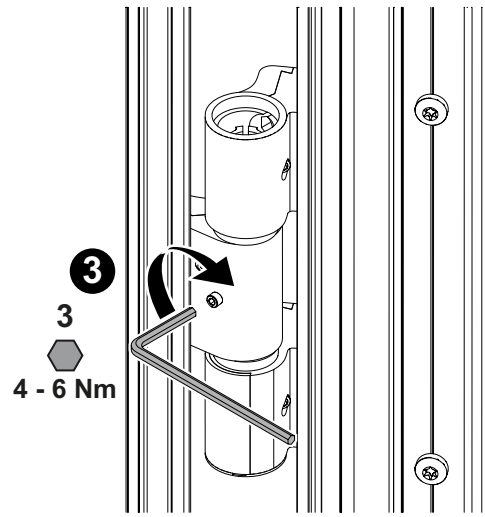
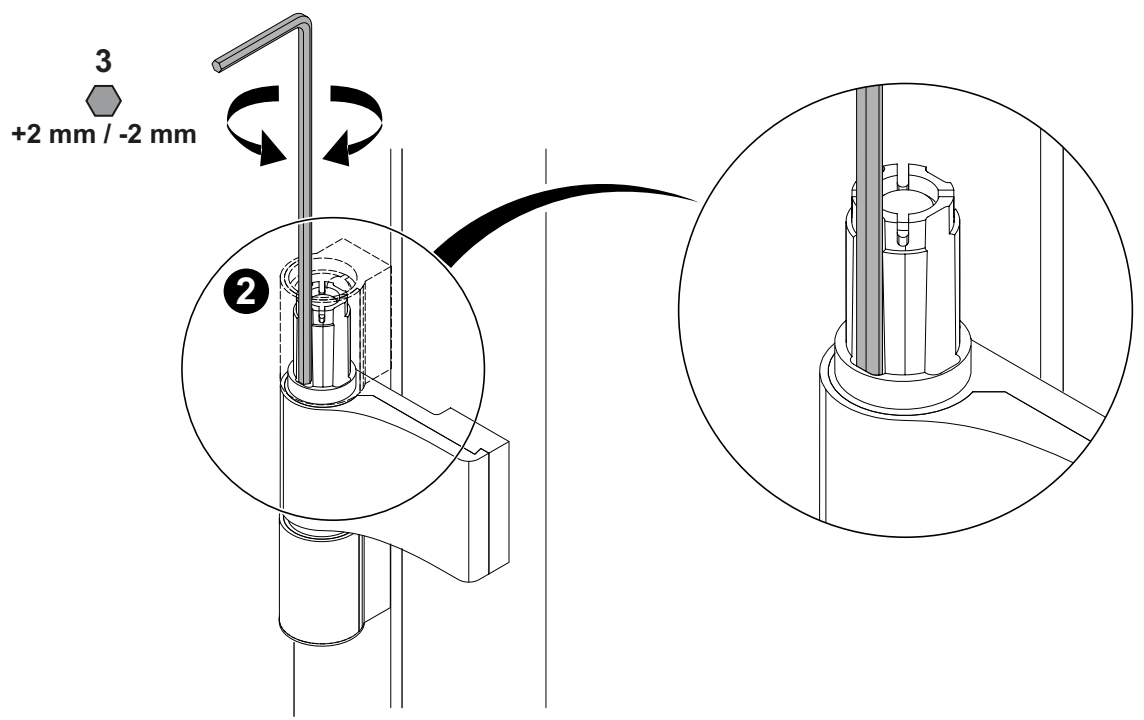
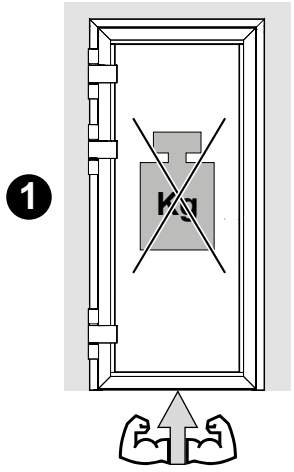
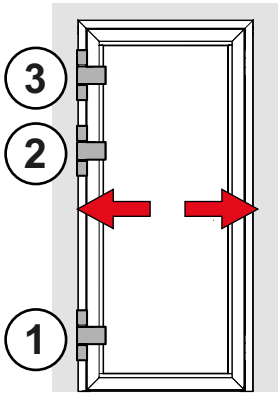

19

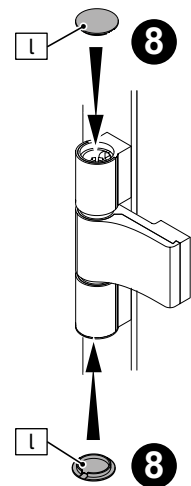
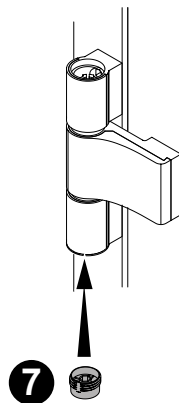
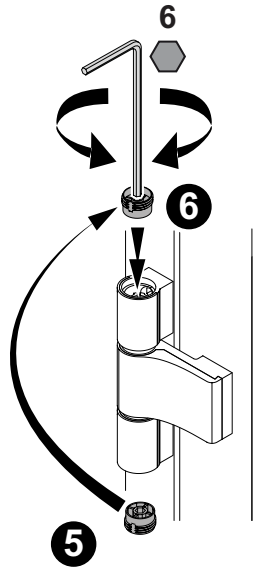
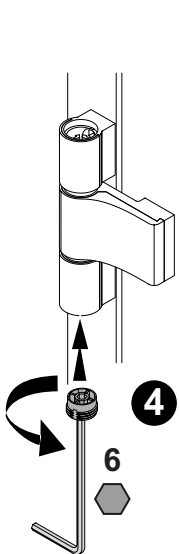
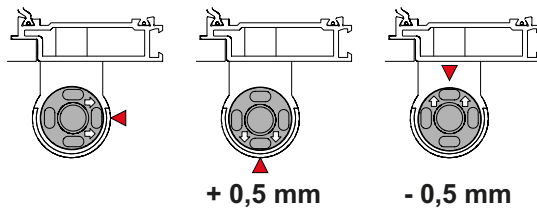
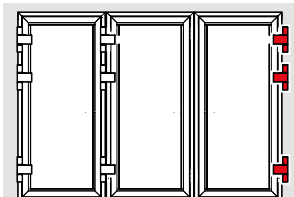
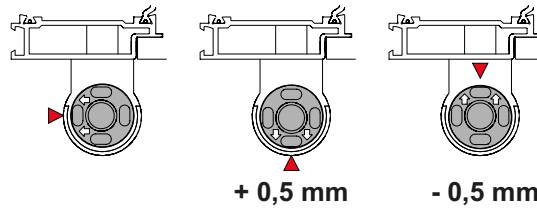
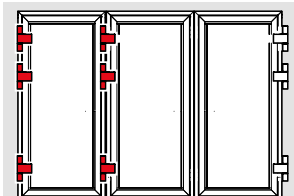
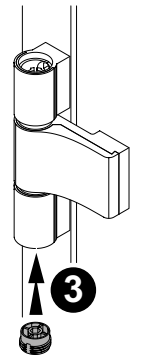
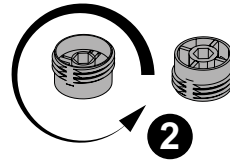
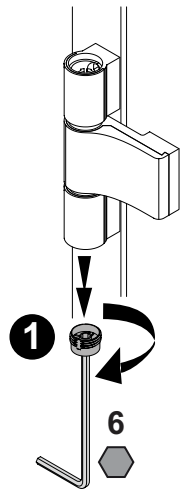
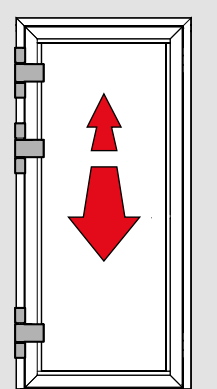

20

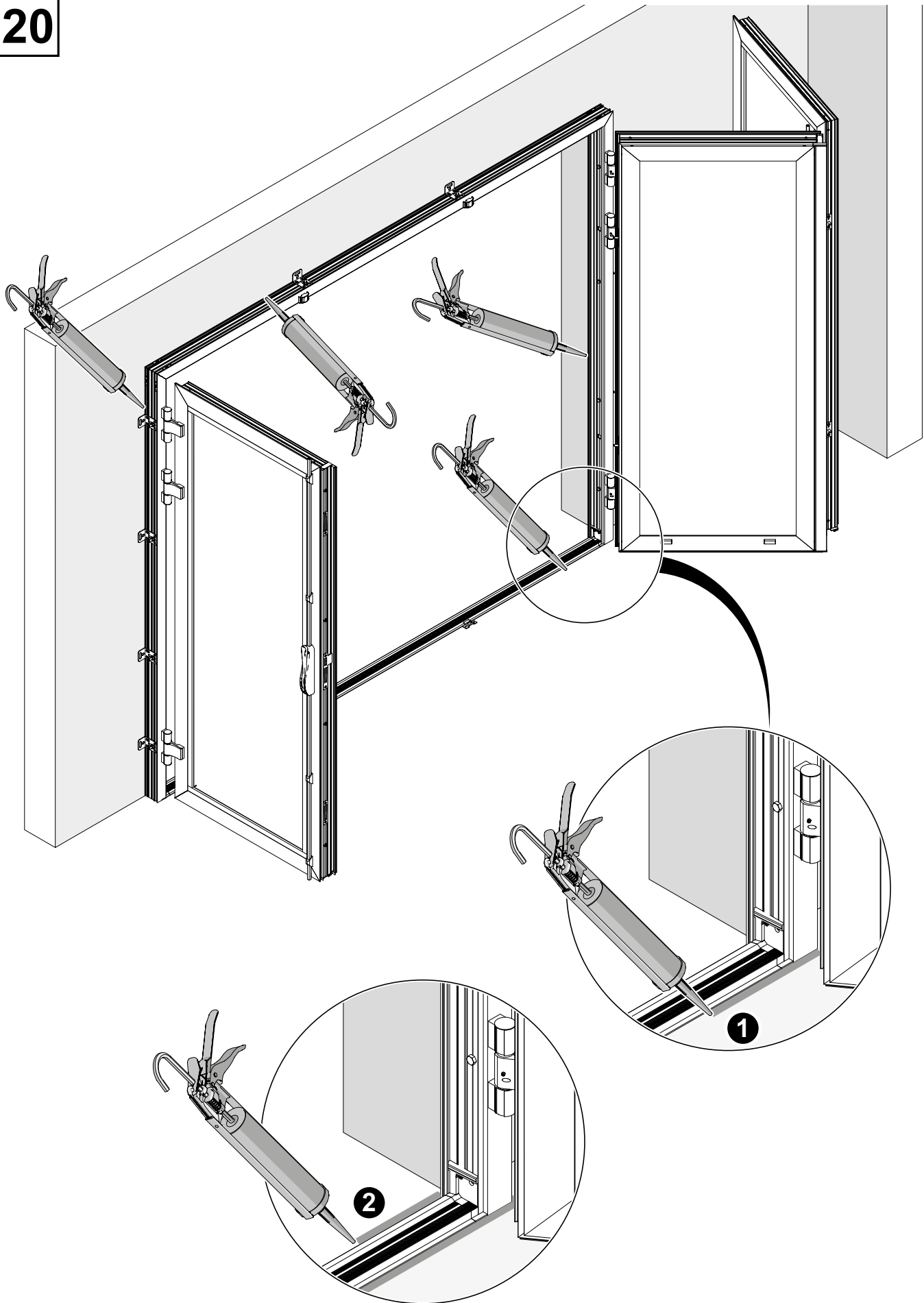

21

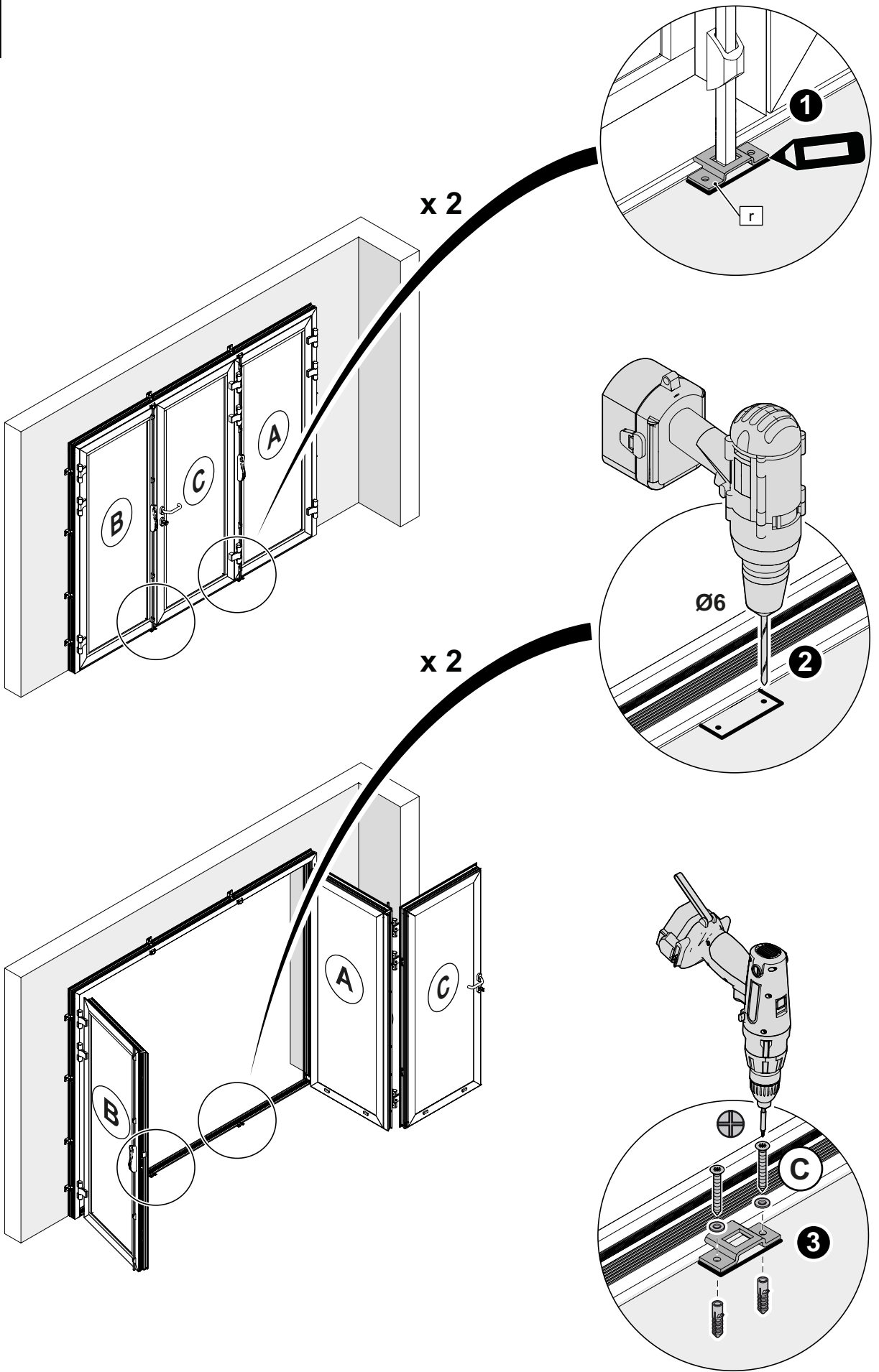









*L'autre entrée principale*



Adresses sur [quefairedemesdechets.fr](http://quefairedemesdechets.fr)