

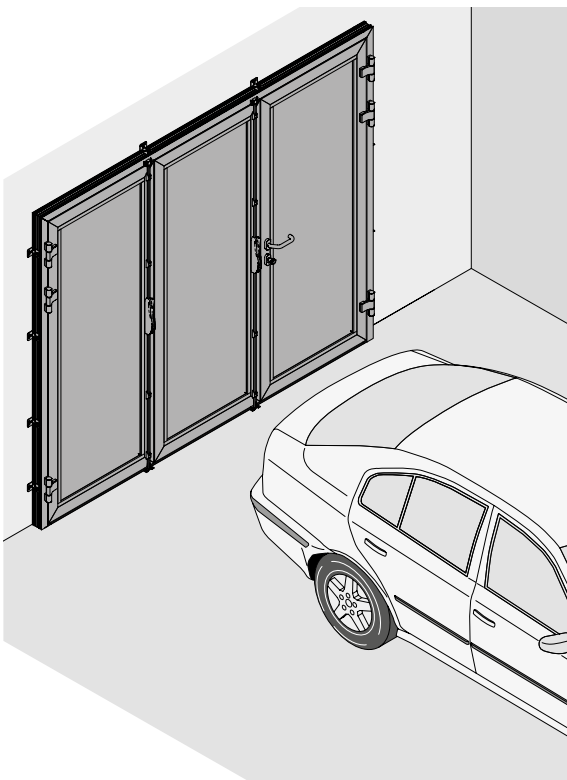

Notice de pose porte 3 vantaux accordéon

Einbauanleitung 3-flügelige Harmonikatür

Installation instructions for 3-leaf folding door

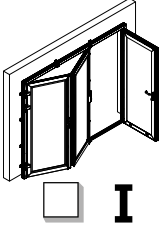
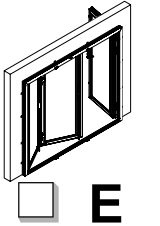
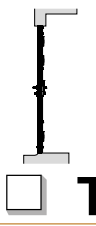
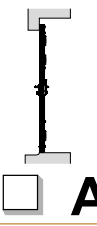
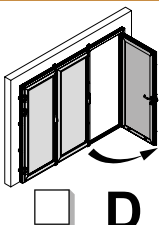
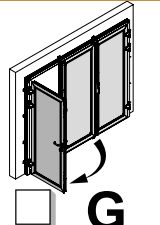

Option / Option / Variante	Oui / Ja / Yes	Non / Nein / No
Vérin Gas spring Gasfeder		
Ferme porte Door closer Türschliesser		
Arrêt de porte à visser Screw-on door stop Türfeststeller zum Anschrauben		
Arrêt de porte à sceller Door stop to seal Türfeststeller zum Versiegeln		
Bloqueur pour ferme porte Door closer blocker Türschließerblocker		

Ouverture Öffnungsrichtung Opening	Intérieure Nach Innen To the inside	Extérieure Nach Außen To the outside
	 I	 E
Pose Montage Anschlag Mounting stop	Tunnel In der Öffnung Build in	Applique Hinter der Öffnung Build on
	 T	 A
Tirant Richtung Innen Pulling direction	Droite Rechts Right	Gauche Links Left
	 D	 G
Configuration / Konfiguration / Configuration :		
<input type="checkbox"/> <input type="checkbox"/> <input type="checkbox"/> →  Pages / Seiten / Pages 2-3		

IAD

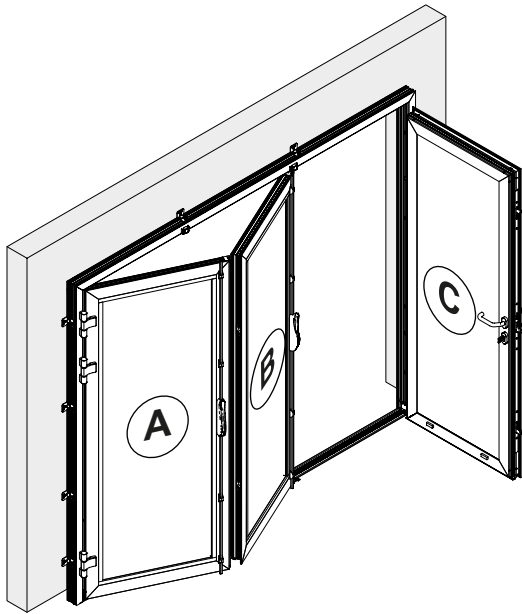

ITD

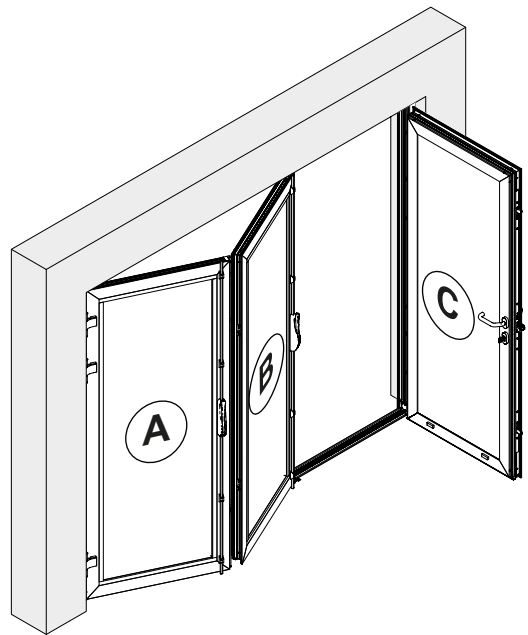

IAG

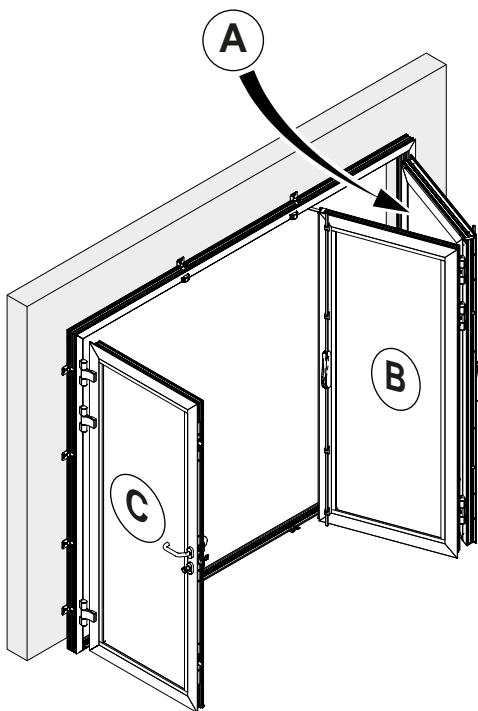

ITG

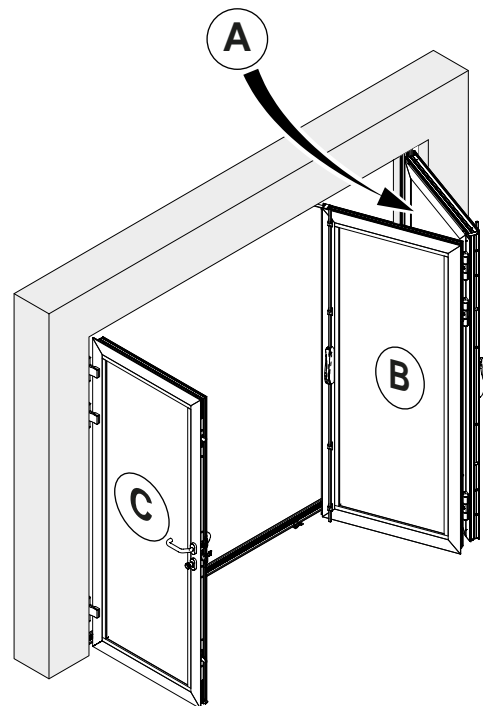

EAD

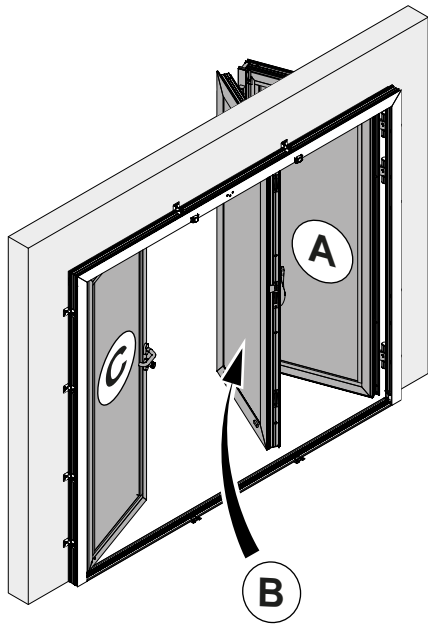

ETD

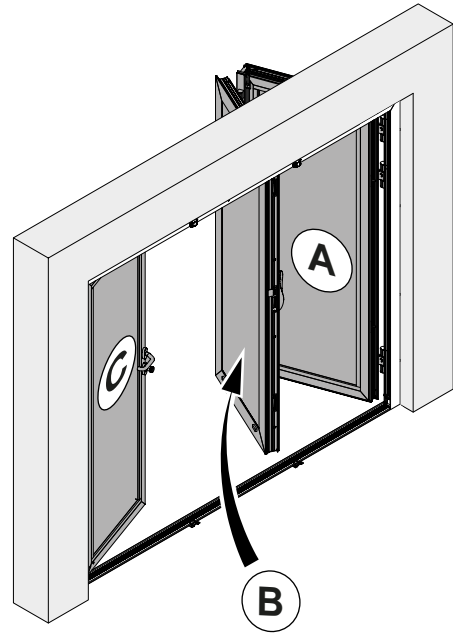



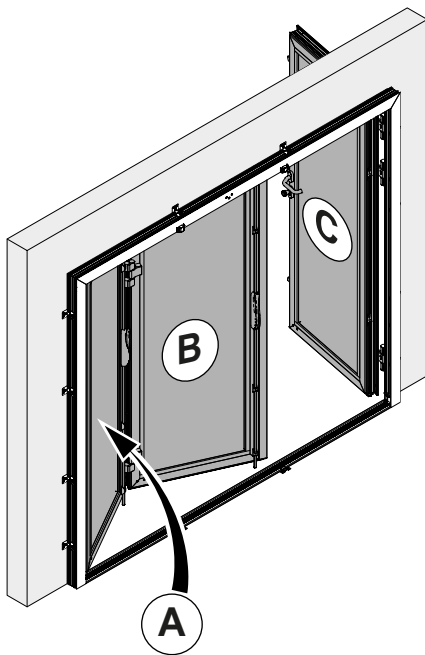



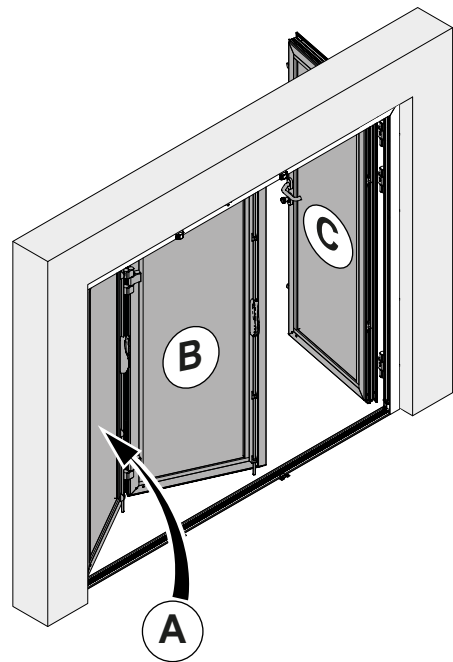

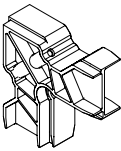
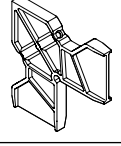
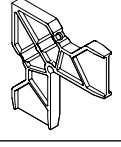

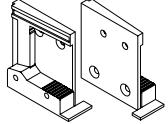
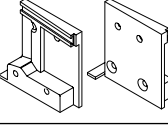

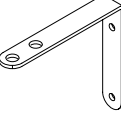

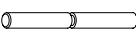

EAG

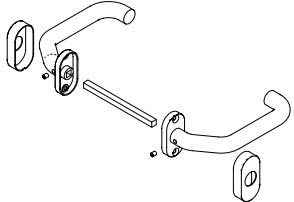

ETG

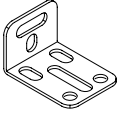
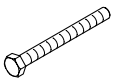

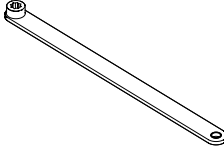
Pièces fournies / Parts supplied / Gelieferte Teile			
a			x2
b		Si ouverture intérieure If inside opening Bei Öffnung nach innen	x2
c		Si ouverture extérieure If outside opening Bei Öffnung nachaußen	x2
d			x8
e	 M5 x 25		x8
f		Si ouverture intérieure If inside opening Bei Öffnung nach innen	x2
g		Si ouverture extérieure If outside opening Bei Öffnung nachaußen	x2
h			x2
i	 M4,2 x 32		x4
j			x1
k			x1
l			x18
m			x9
n			x5
o	 M6 x 20		x3
p	 M4 x 16		x8
q			x1

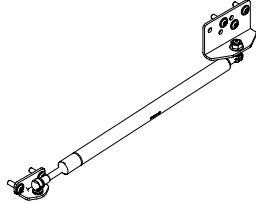
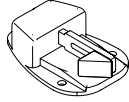
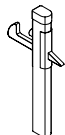
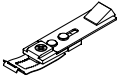
Pièces fournies / Parts supplied / Gelieferte Teile			
r			x2
s			x10
t		Si fixation applique If build in Bei Option hinter der Öffnung	x10
u	 M8 x 80	Si fixation applique If build in Bei Option hinter der Öffnung	x8
v	 M8	Si fixation applique If build in Bei Option hinter der Öffnung	x10
w	 M8 x 20	Si fixation applique If build in Bei Option hinter der Öffnung	x2
x		Si option ferme porte If door closer option Bei Option Türschliesser	x1
y		Si option ferme porte If door closer option Bei Option Türschliesser	x1
z		Si option vérin If gas spring option Bei Option Gasfeder	x1
aa		Si option arrêt de porte à visser If screw-on door stop option Bei Option Türfeststeller zum Anschrauben	x1
bb		Si option arrêt de porte à sceller If door stop to seal option Bei Option Türstopper zum Versiegeln	x1
cc		Si option bloqueur pour ferme porte If door closer blocker option Bei Option Türschließerblocker	x1
gg	Notice de montage Installation instruction Montageanleitung	NFF16599_C	x1



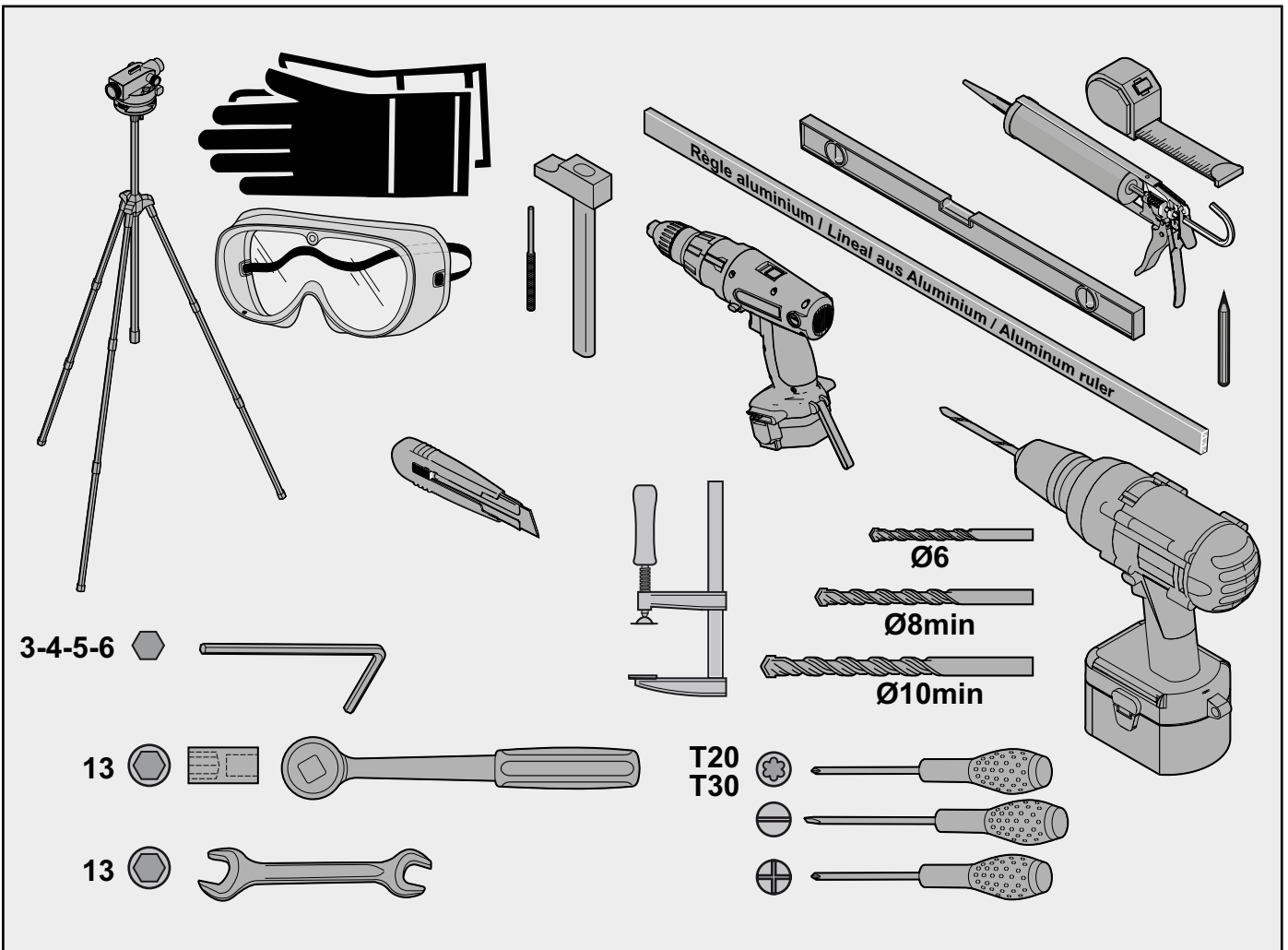



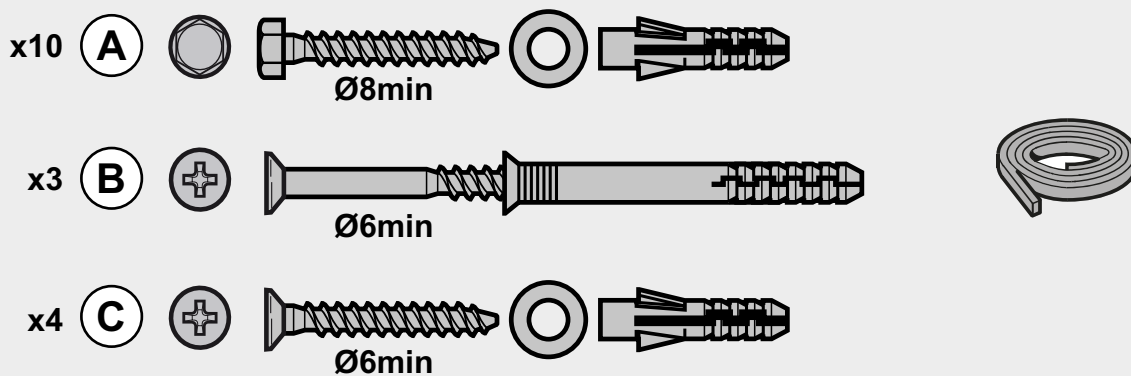

Conseillé, non fourni. À définir en fonction du support.
 Empfohlen, nicht enthalten. Entsprechend der Förderungen zu definieren.
 Recommended, not provided. To be defined according to the support.

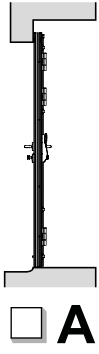

1

Applique
Hinter der Öffnung
Build on



-  (FR) Surfaces planes, de niveau et d'aplomb
-  (DE) Flächen müssen eben und lotrecht sein
-  (GB) Surfaces must be flat and plumb

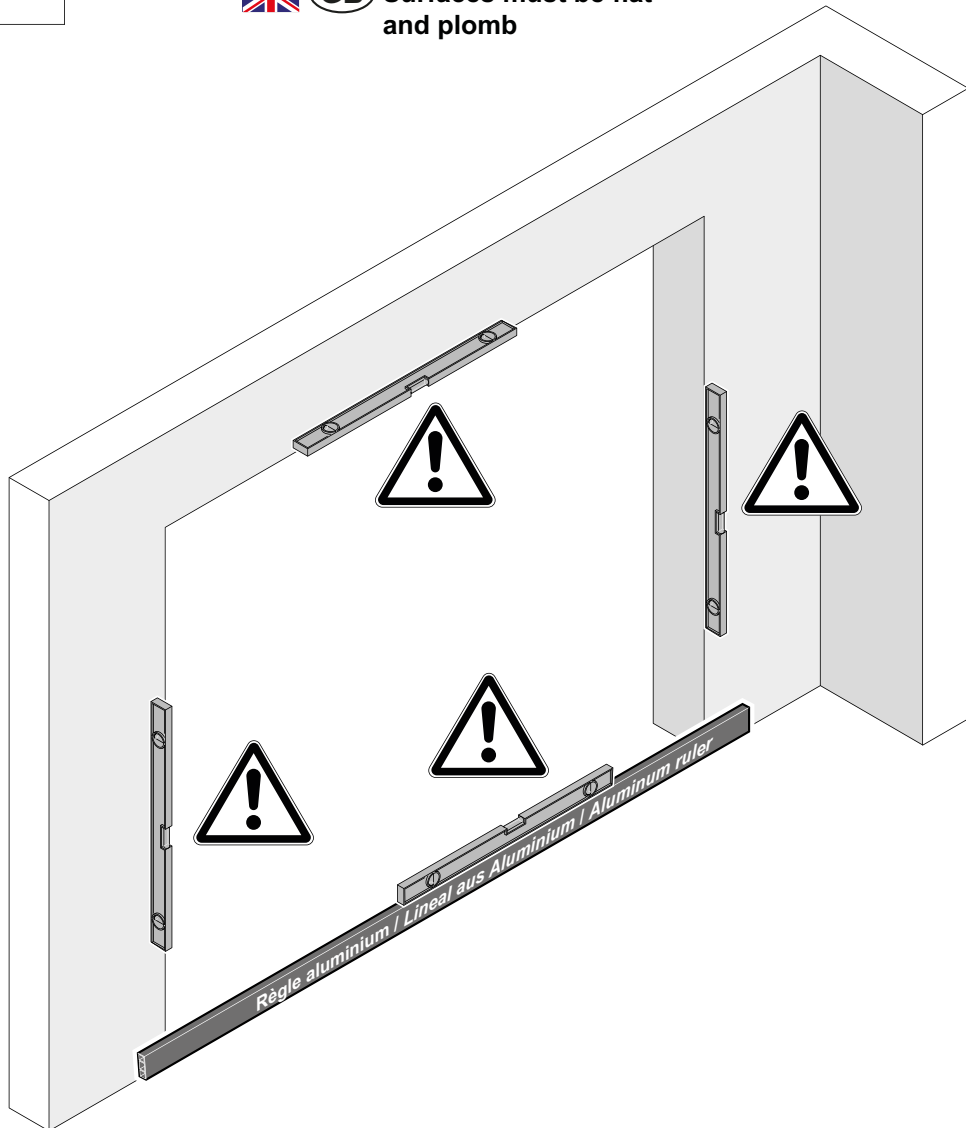

2

Tunnel
In der Öffnung
Build in

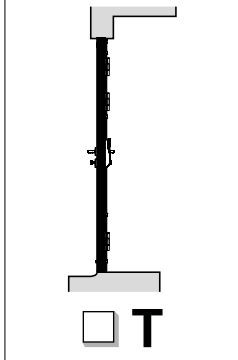

FR

Surfaces planes,
de niveau et d'aplomb



DE

Flächen müssen eben
und lotrecht sein



GB

Surfaces must be flat
and plumb

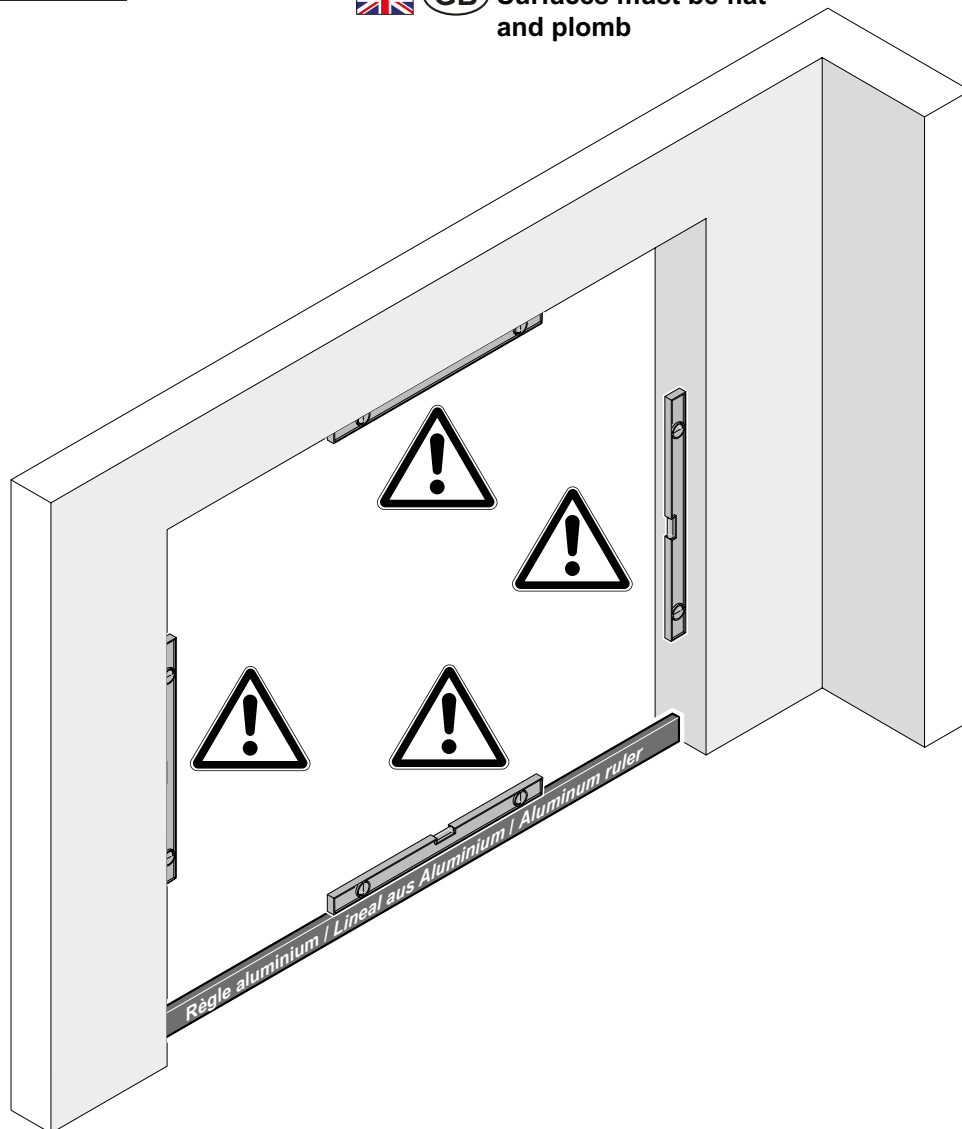

3

Applique
Hinter der Öffnung
Build on

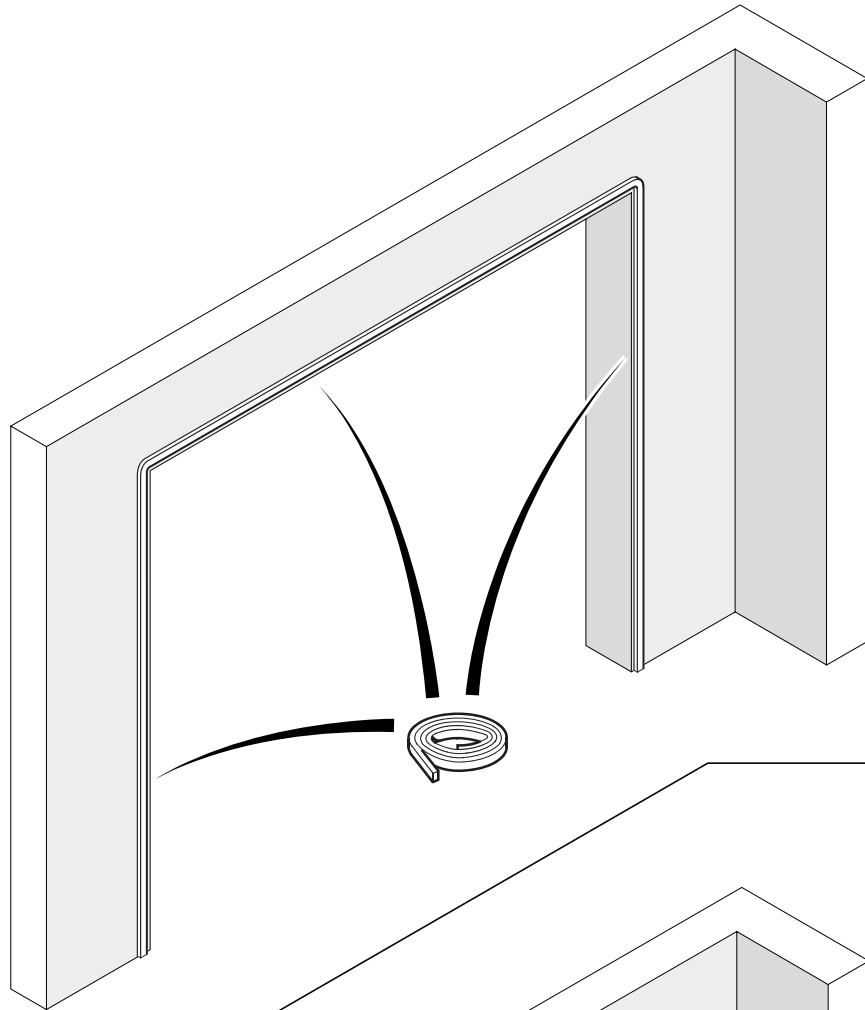
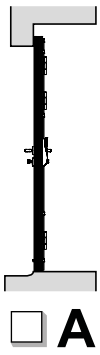

Tunnel
In der Öffnung
Build in

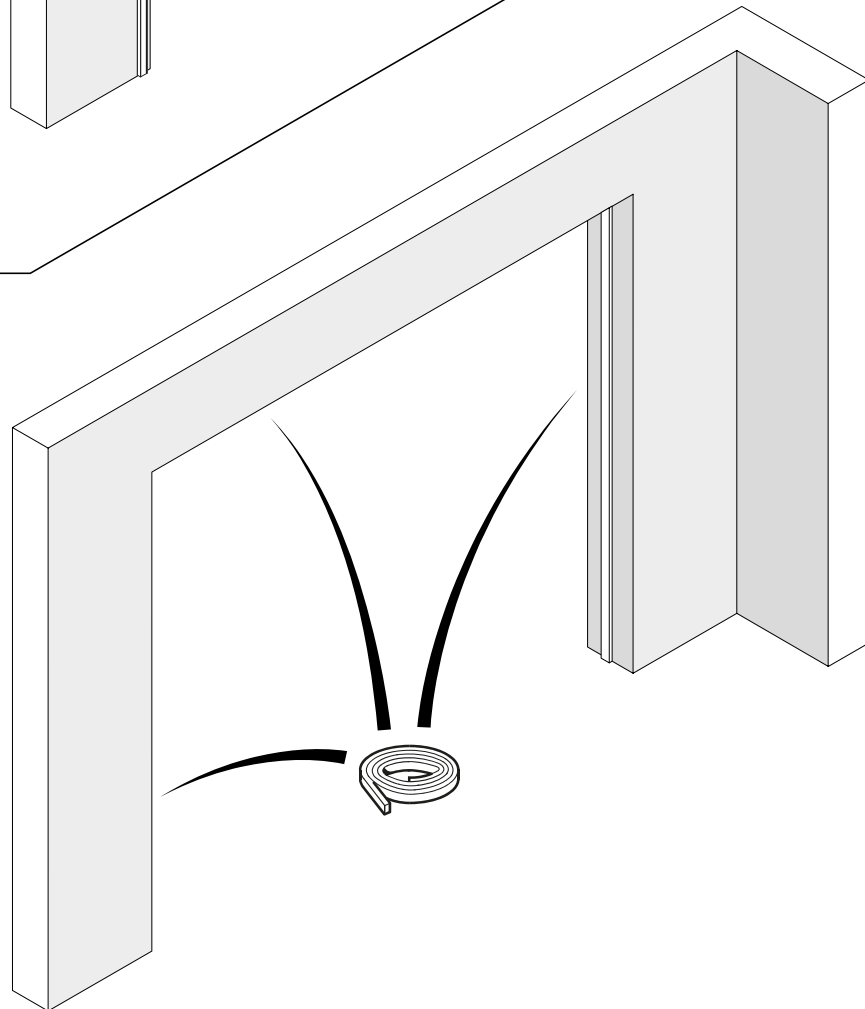
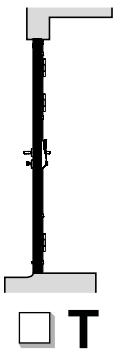

4

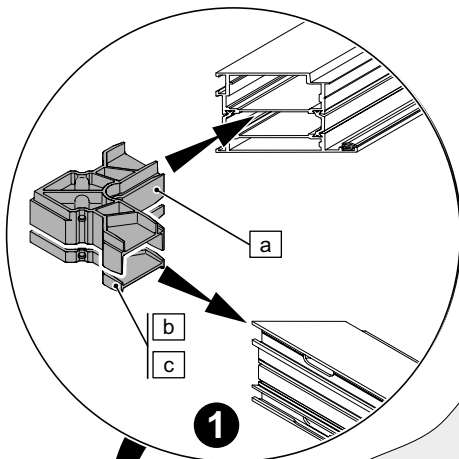
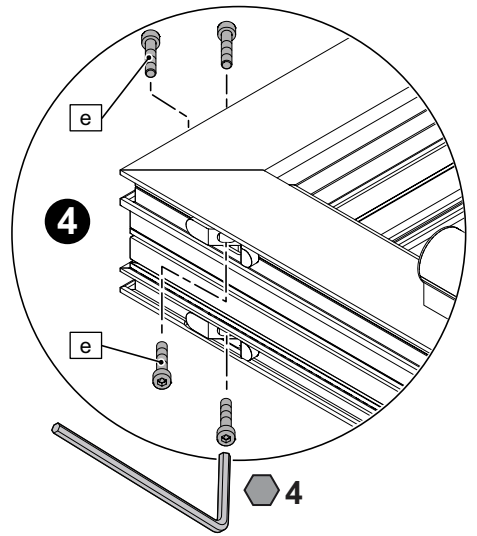
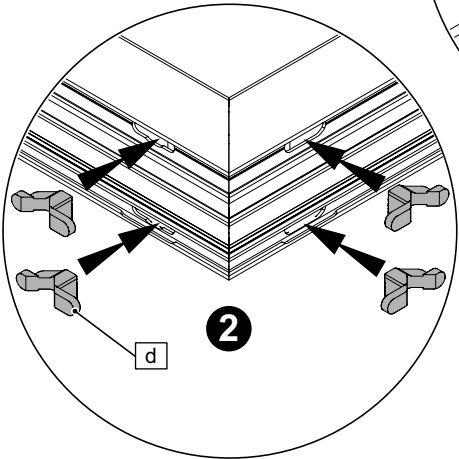
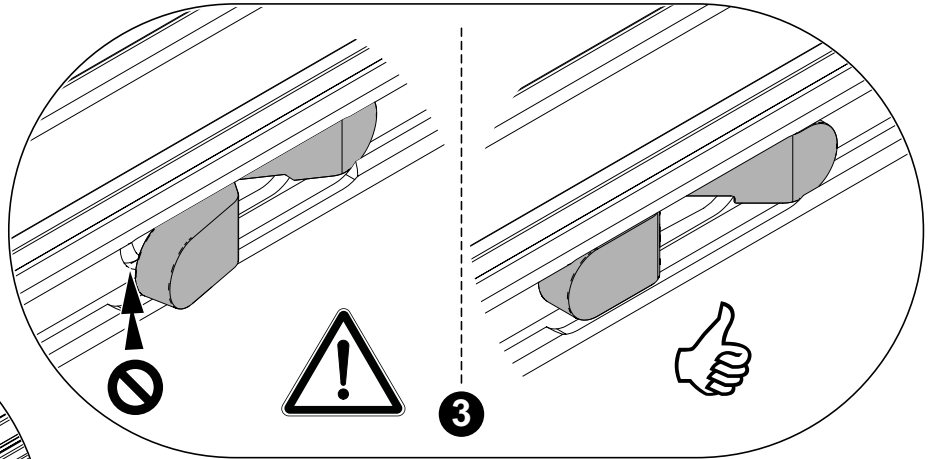

x 2

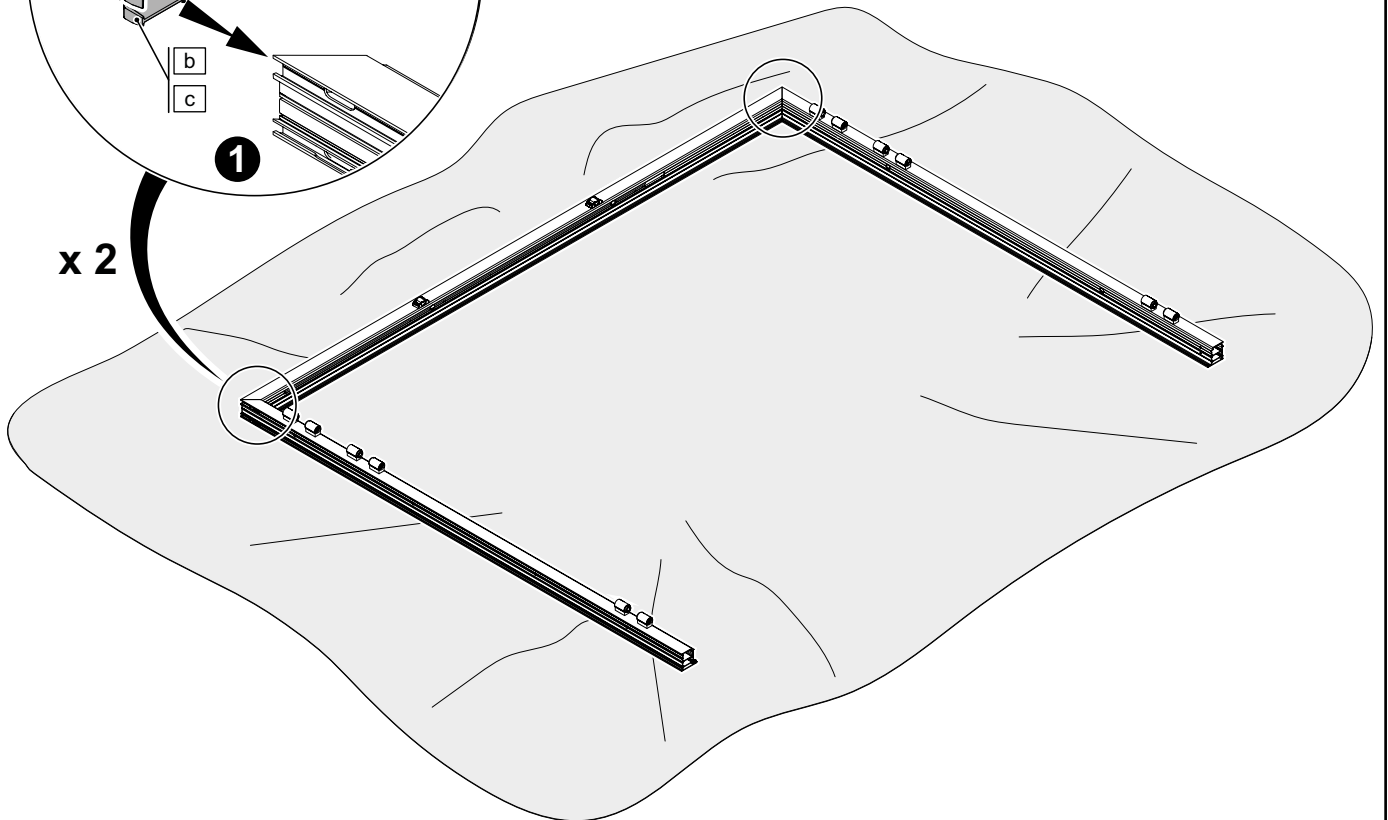

5

Intérieure
Nach Innen
To the inside

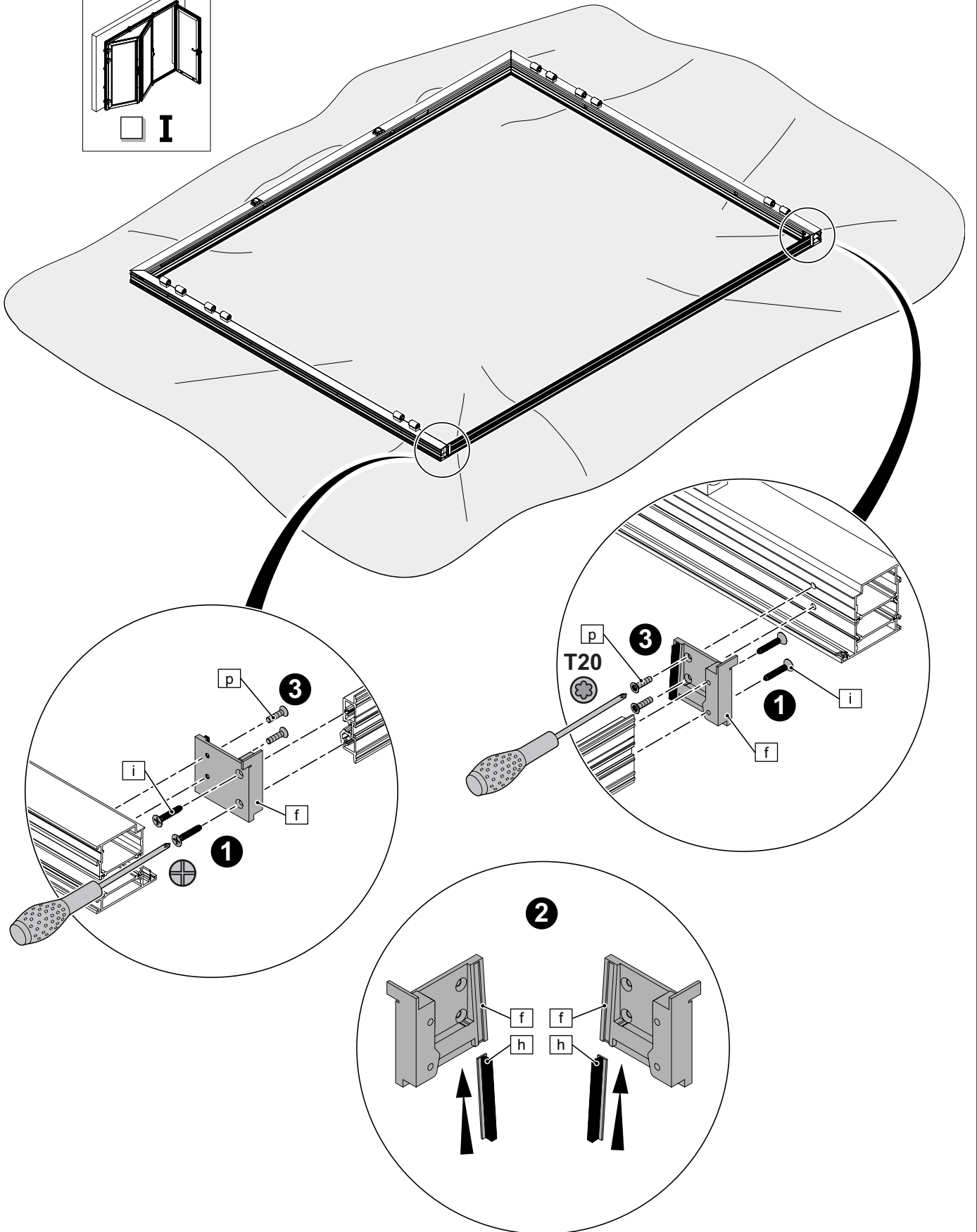
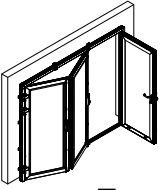

6

Extérieure
Nach Außen
To the outside

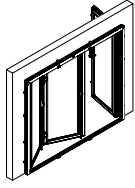

□ **E**

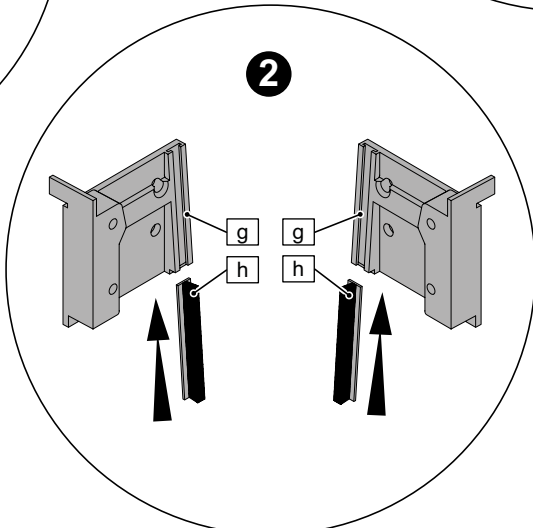
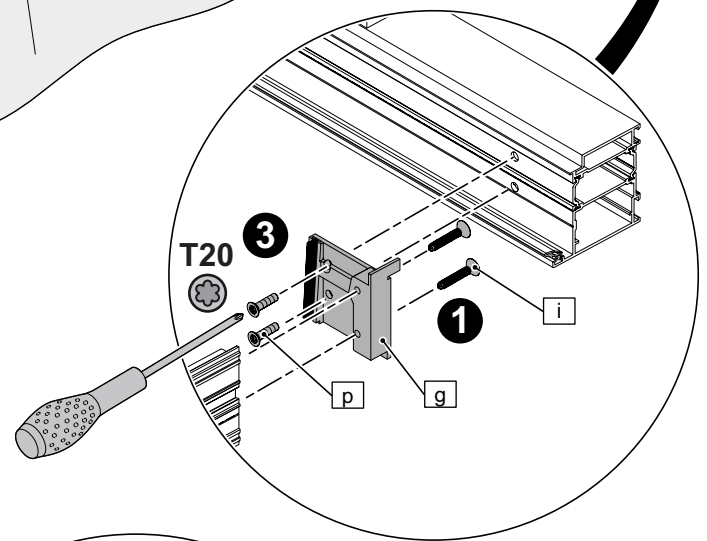
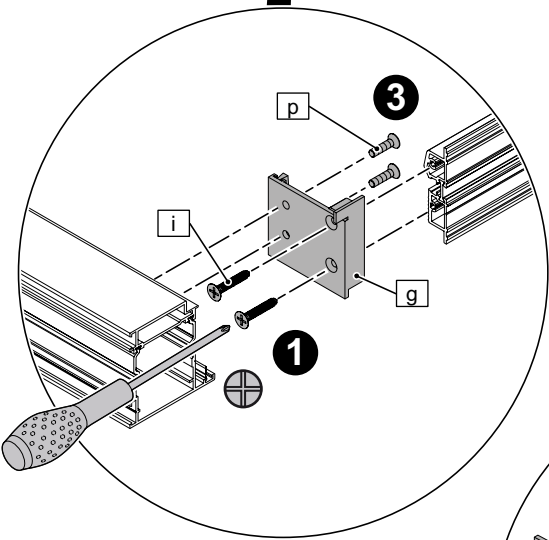
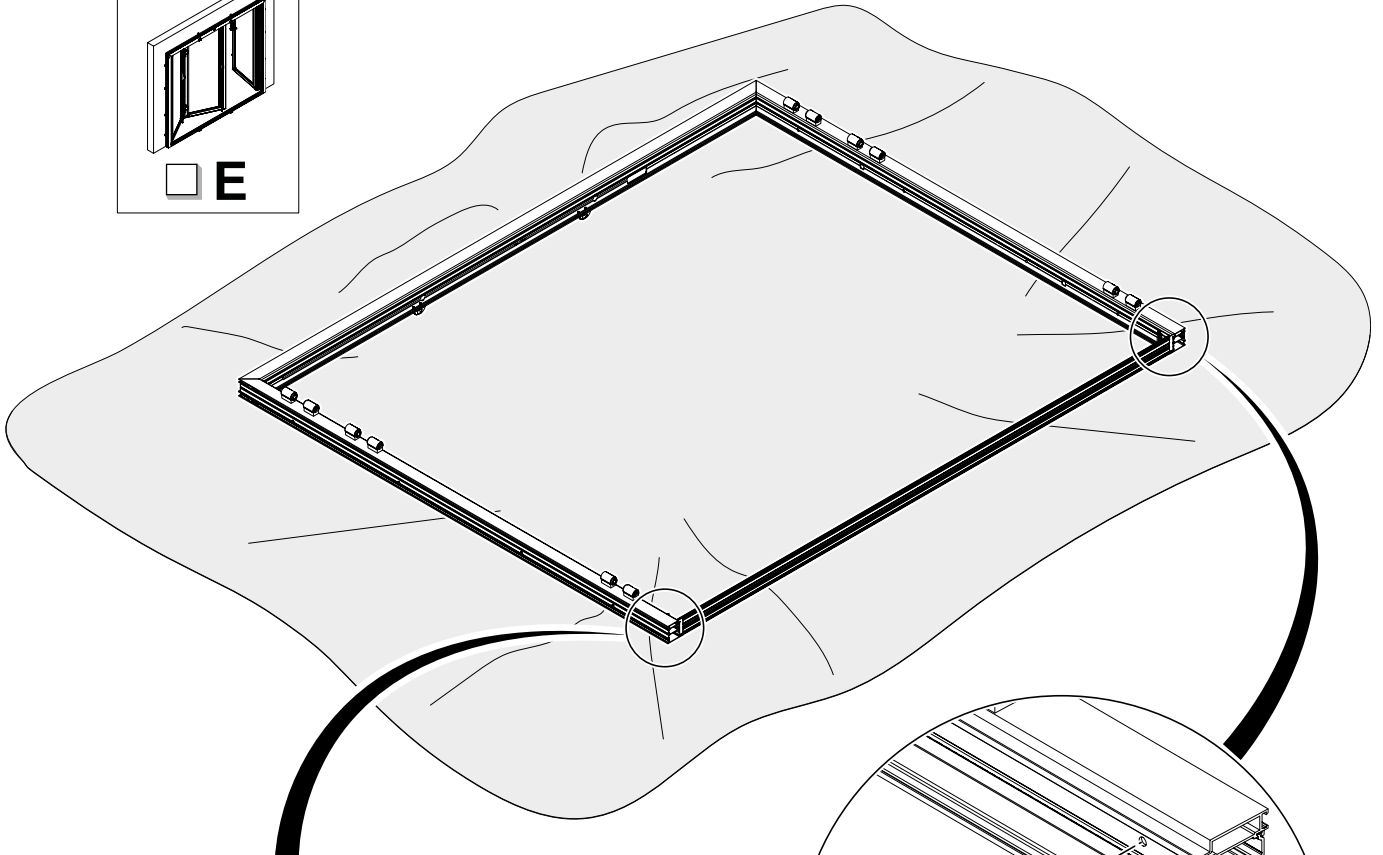

7

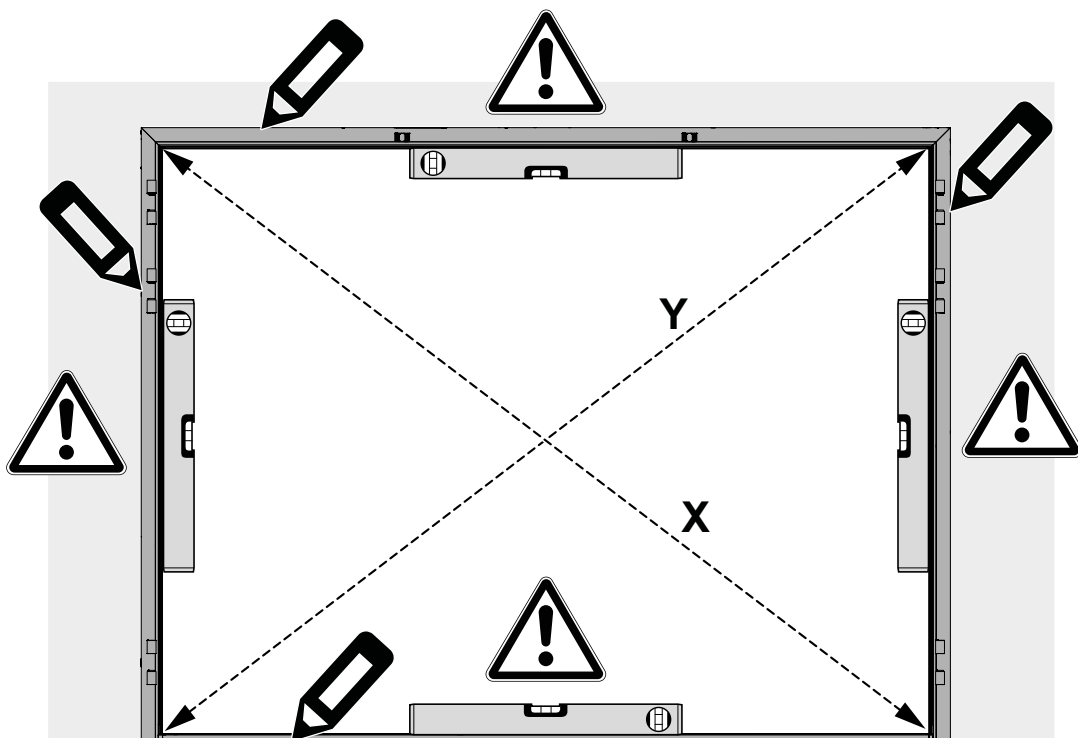

8

Applique
Hinter der Öffnung
Build on

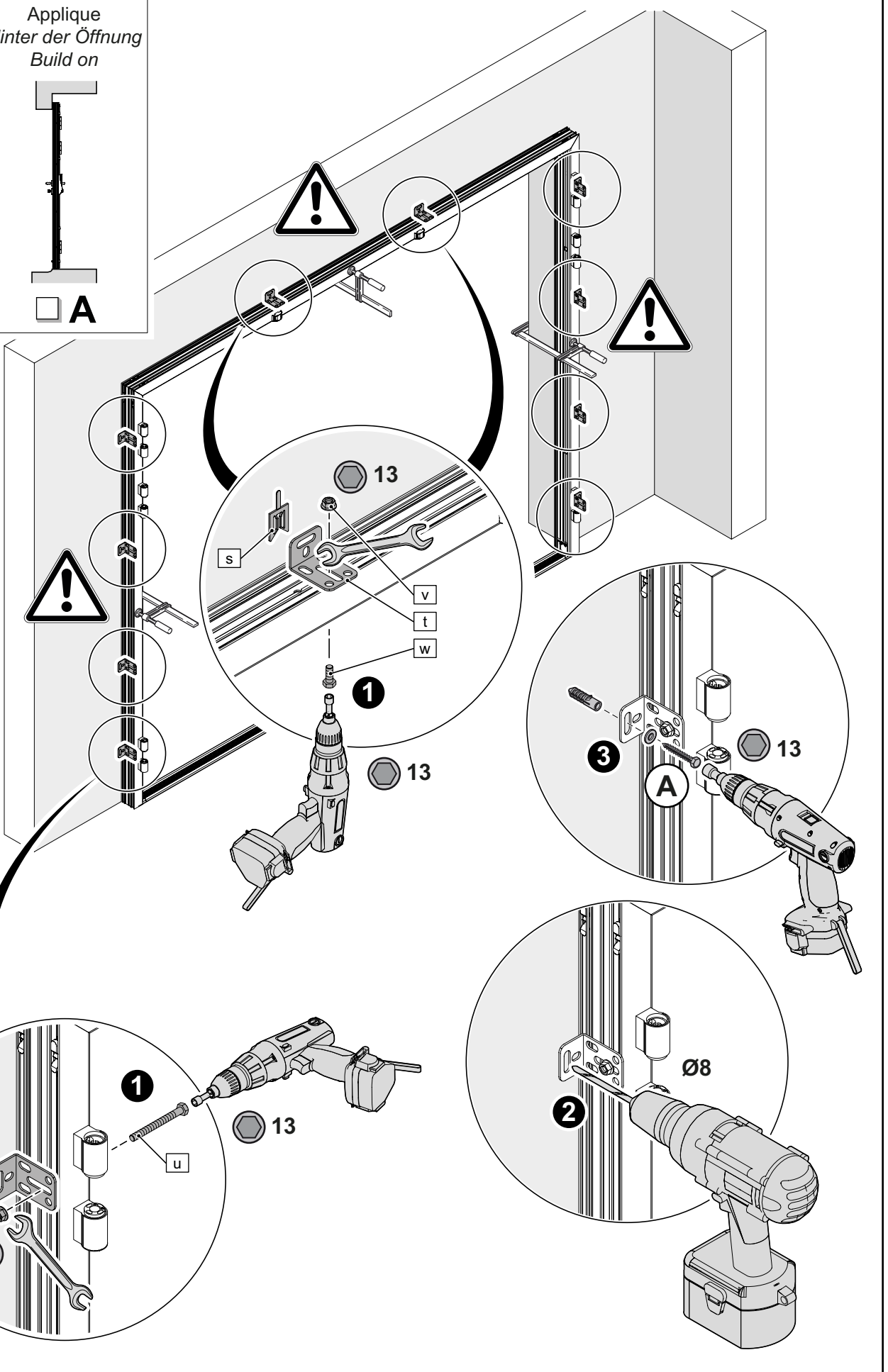
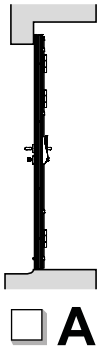



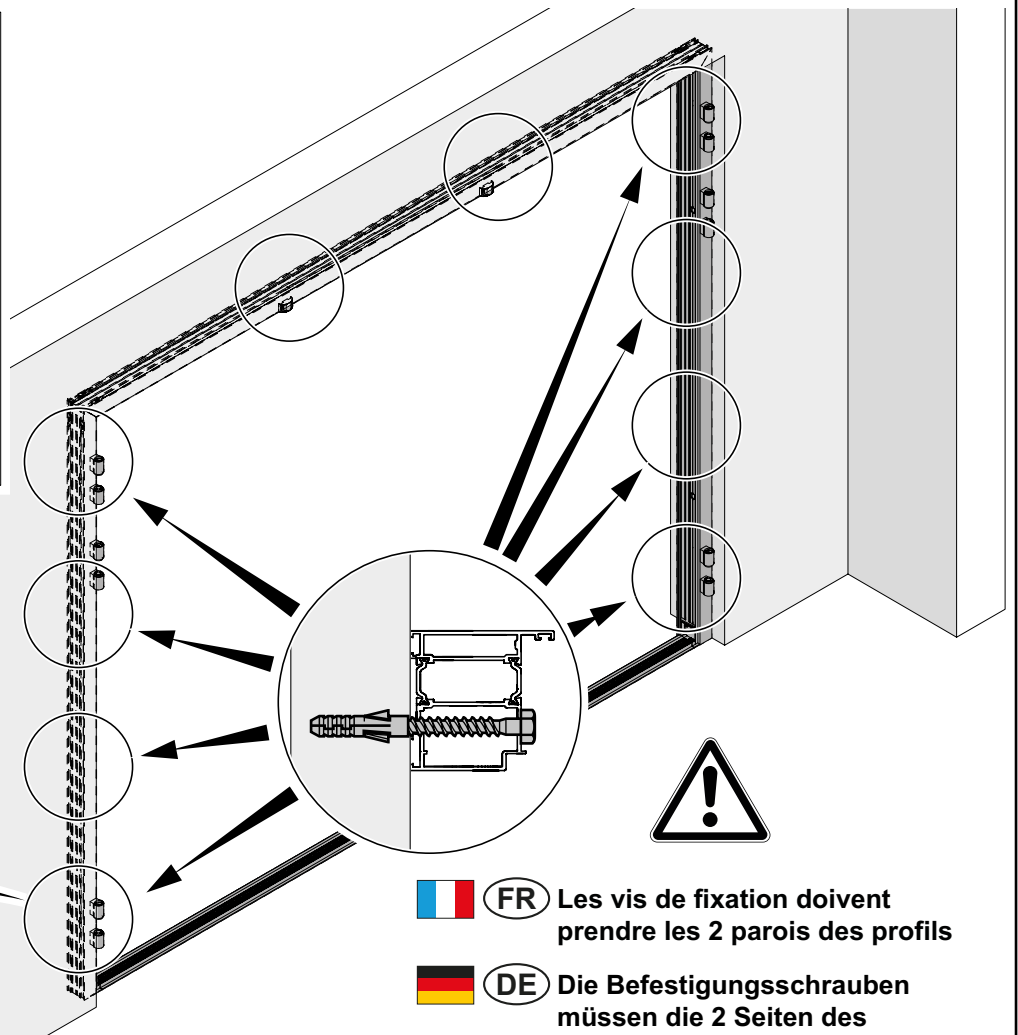
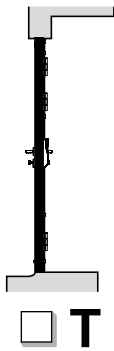

9

Tunnel
In der Öffnung
Build in

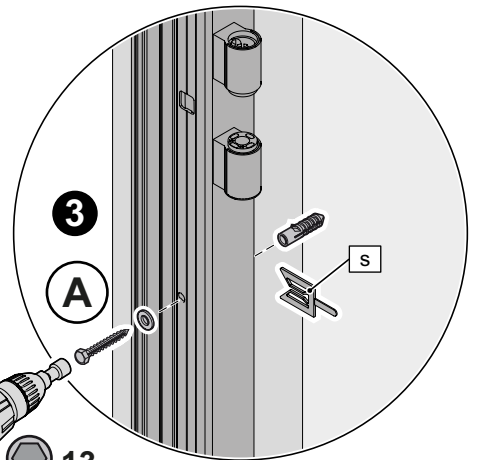
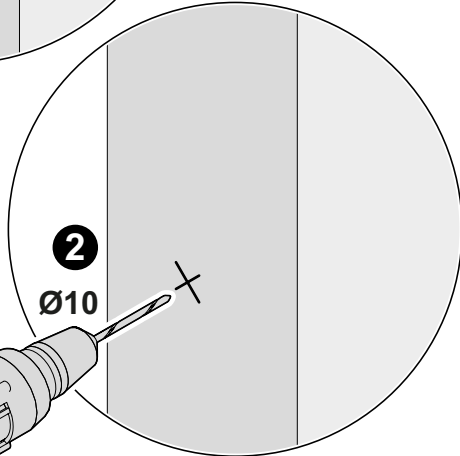
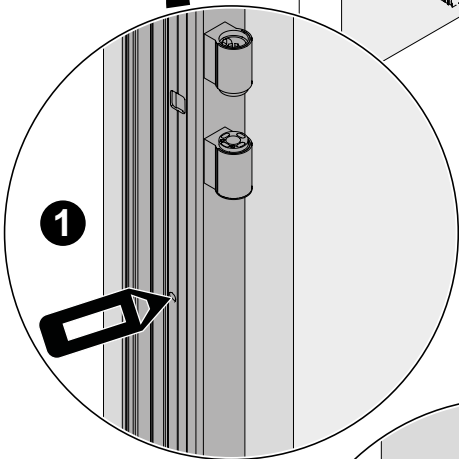

x 10



-  (FR) Les vis de fixation doivent prendre les 2 parois des profils
-  (DE) Die Befestigungsschrauben müssen die 2 Seiten des Profils greifen
-  (GB) The fixing screws must take the 2 walls of the profiles

10

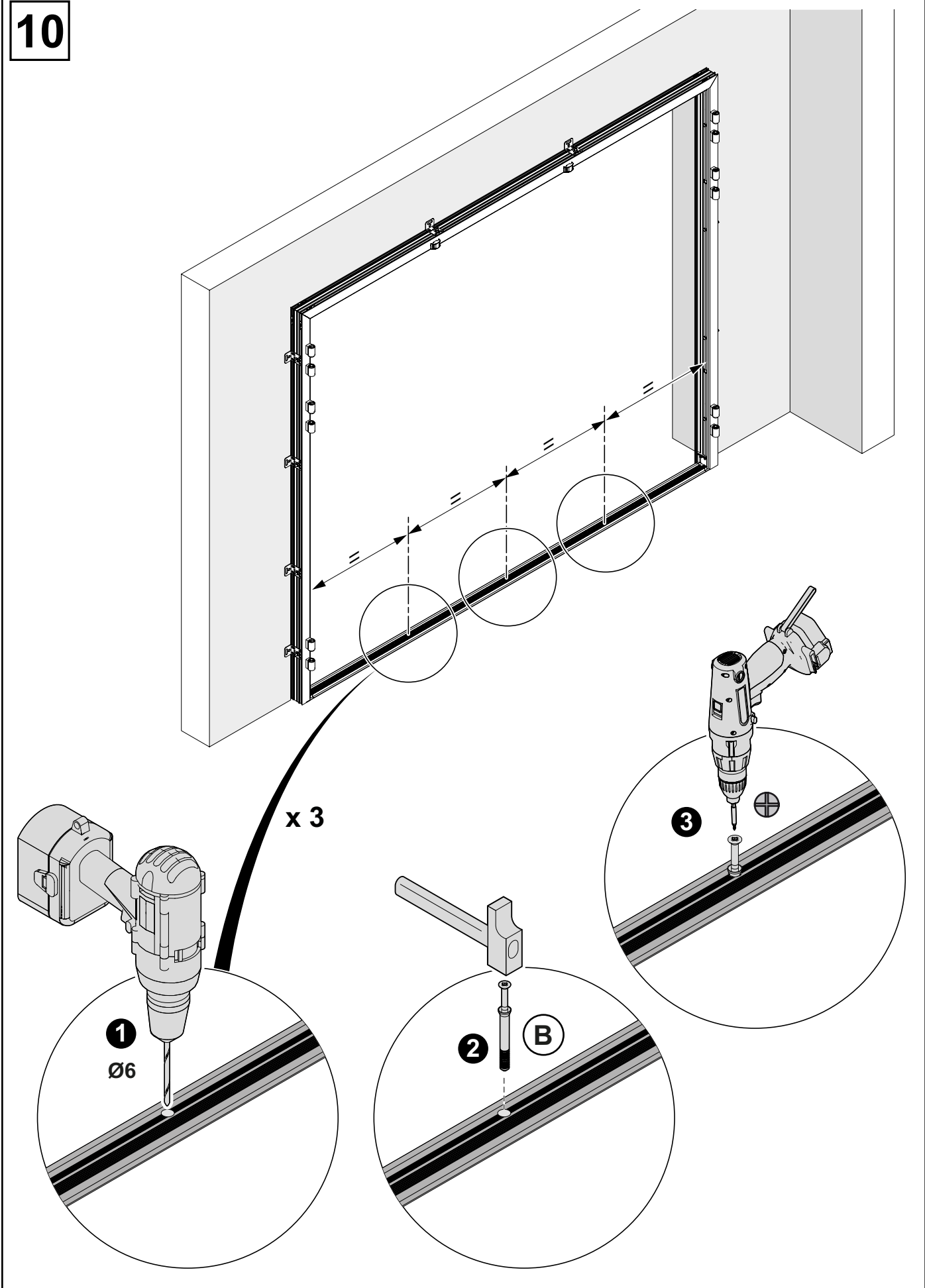

11

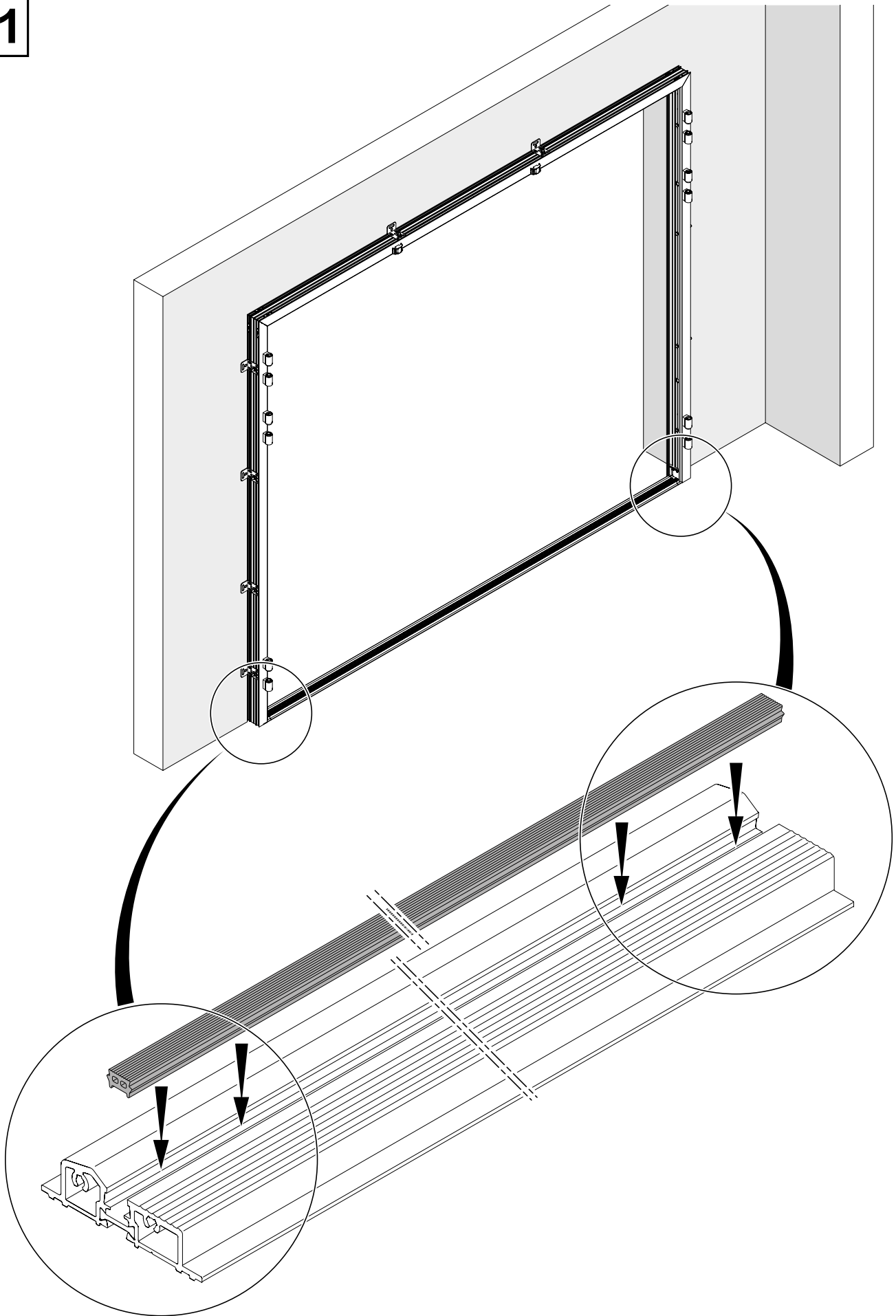

12

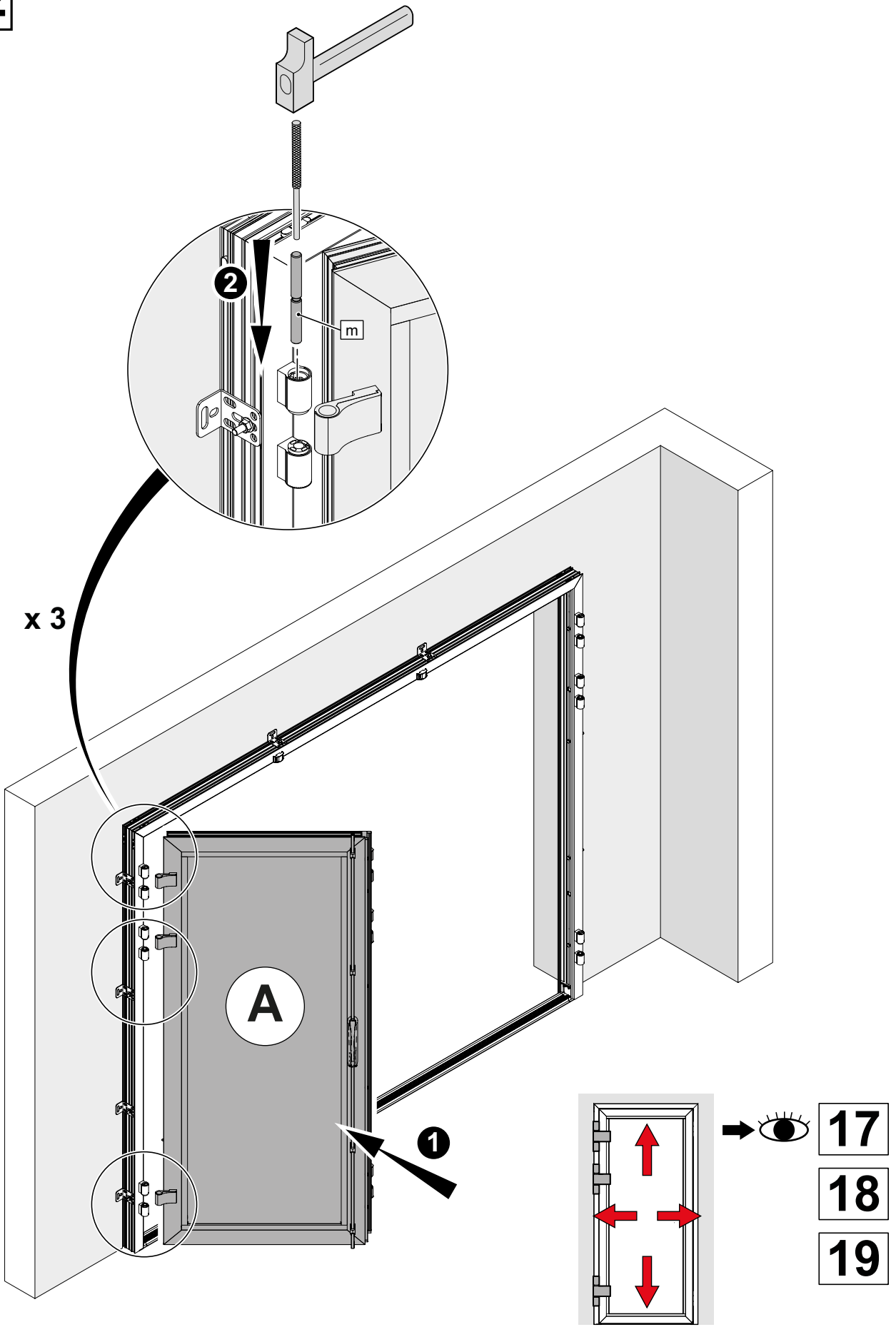

13

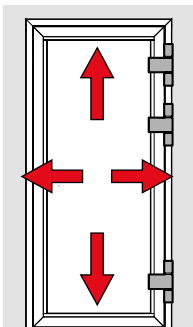
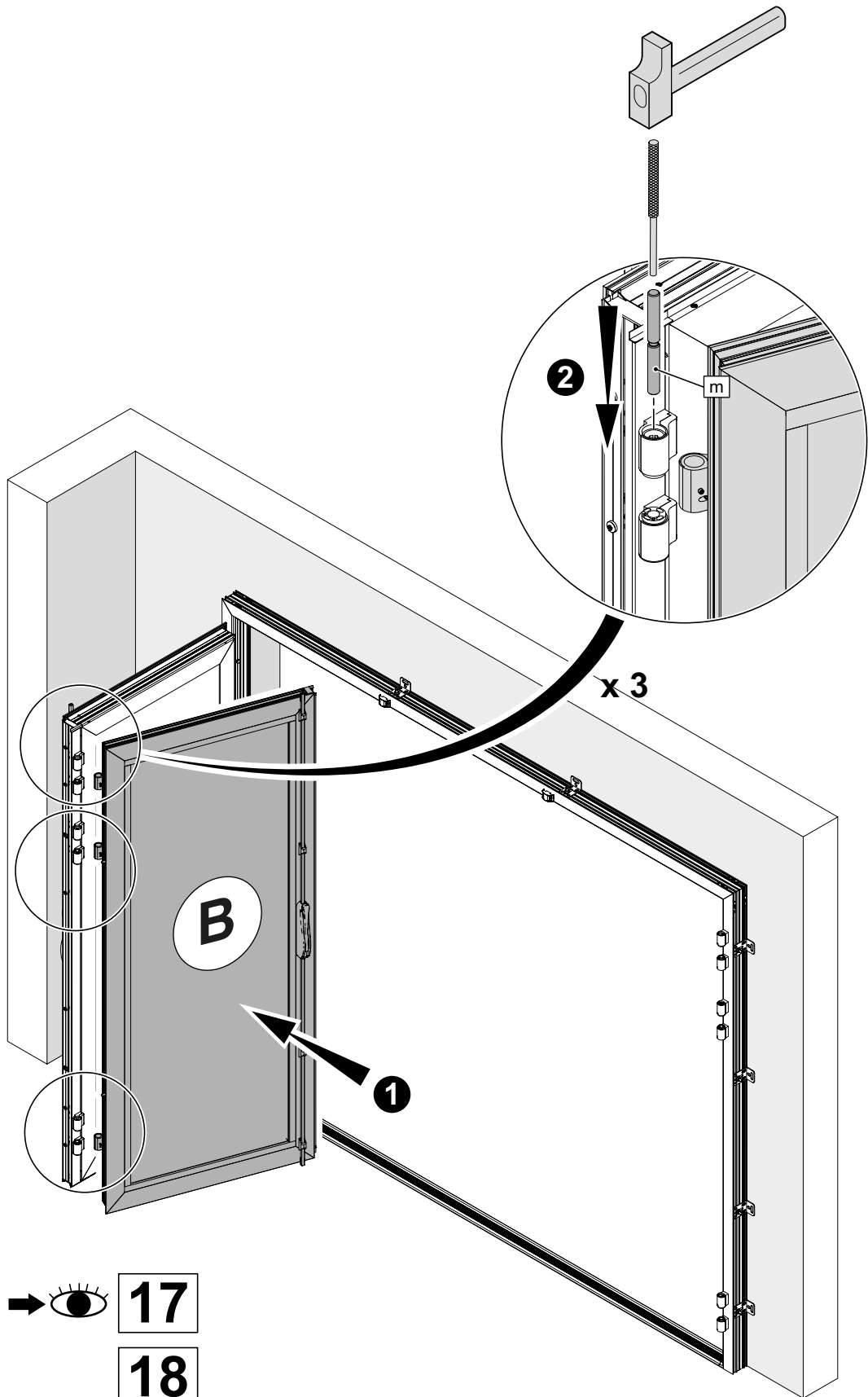

17

18

19

14

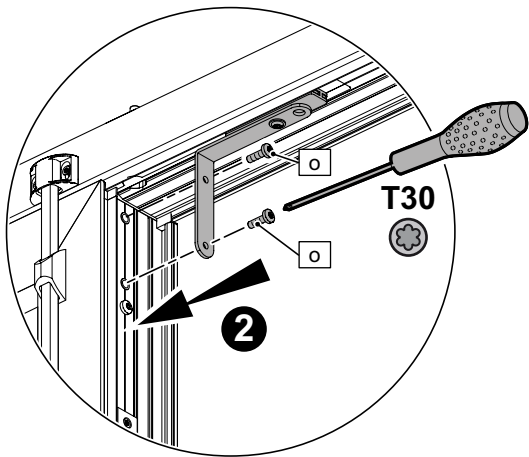

Intérieure
Nach Innen
To the inside

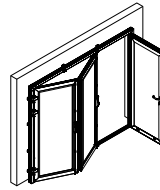

I

Extérieure
Nach Außen
To the outside

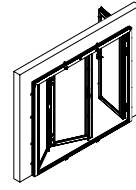

E

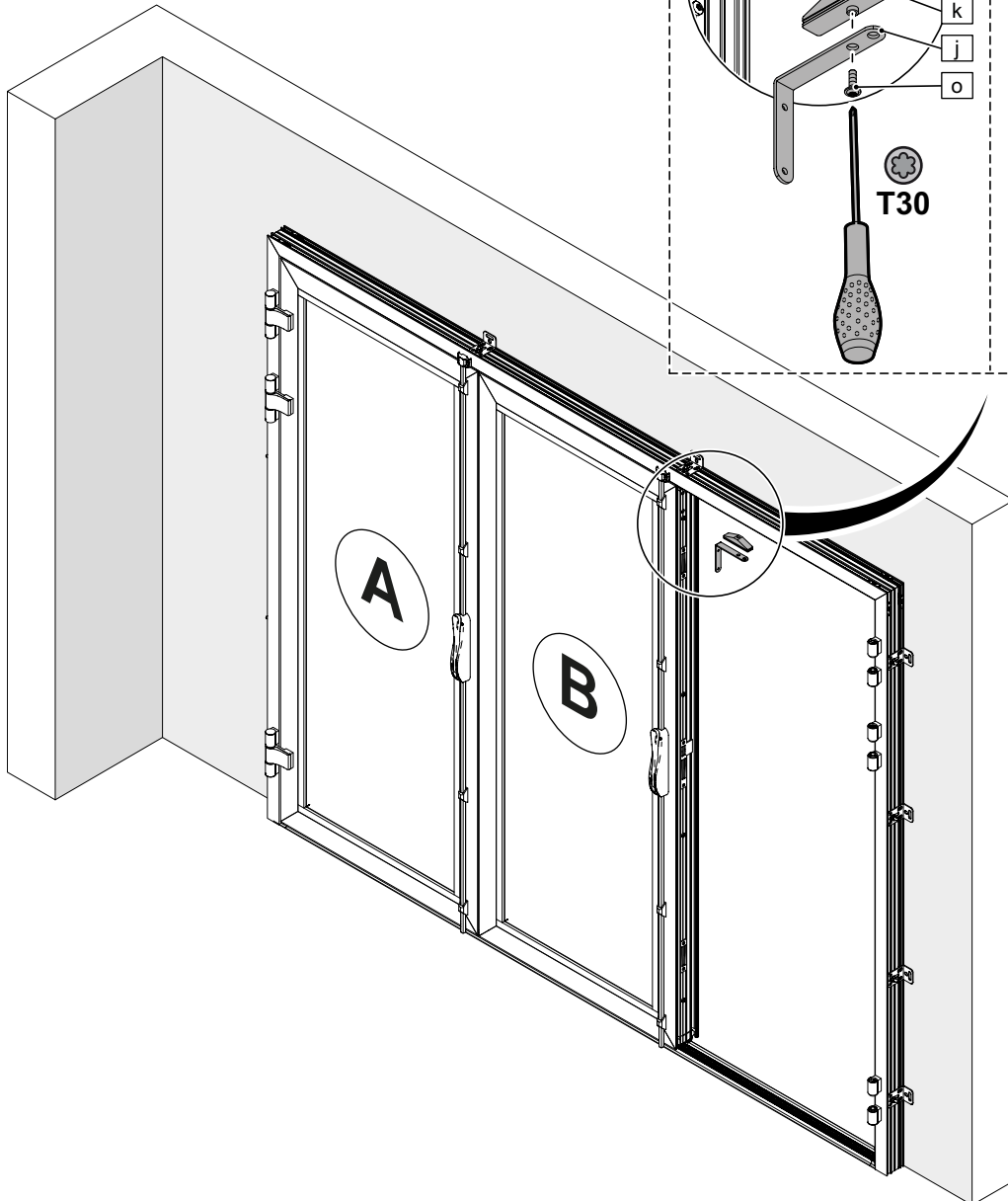
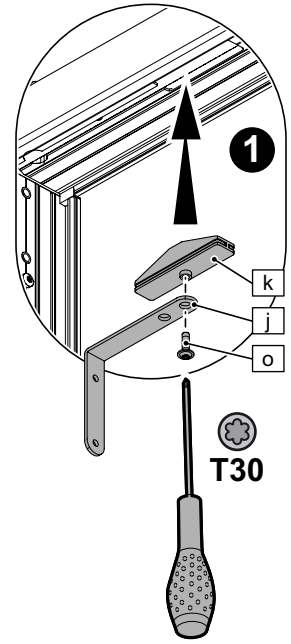
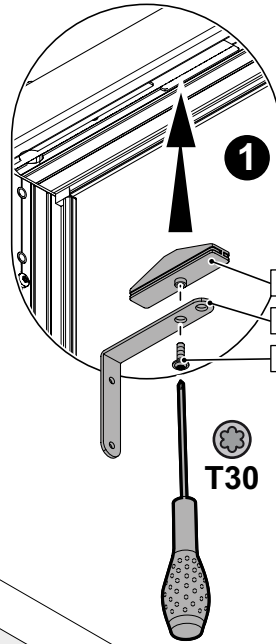

15

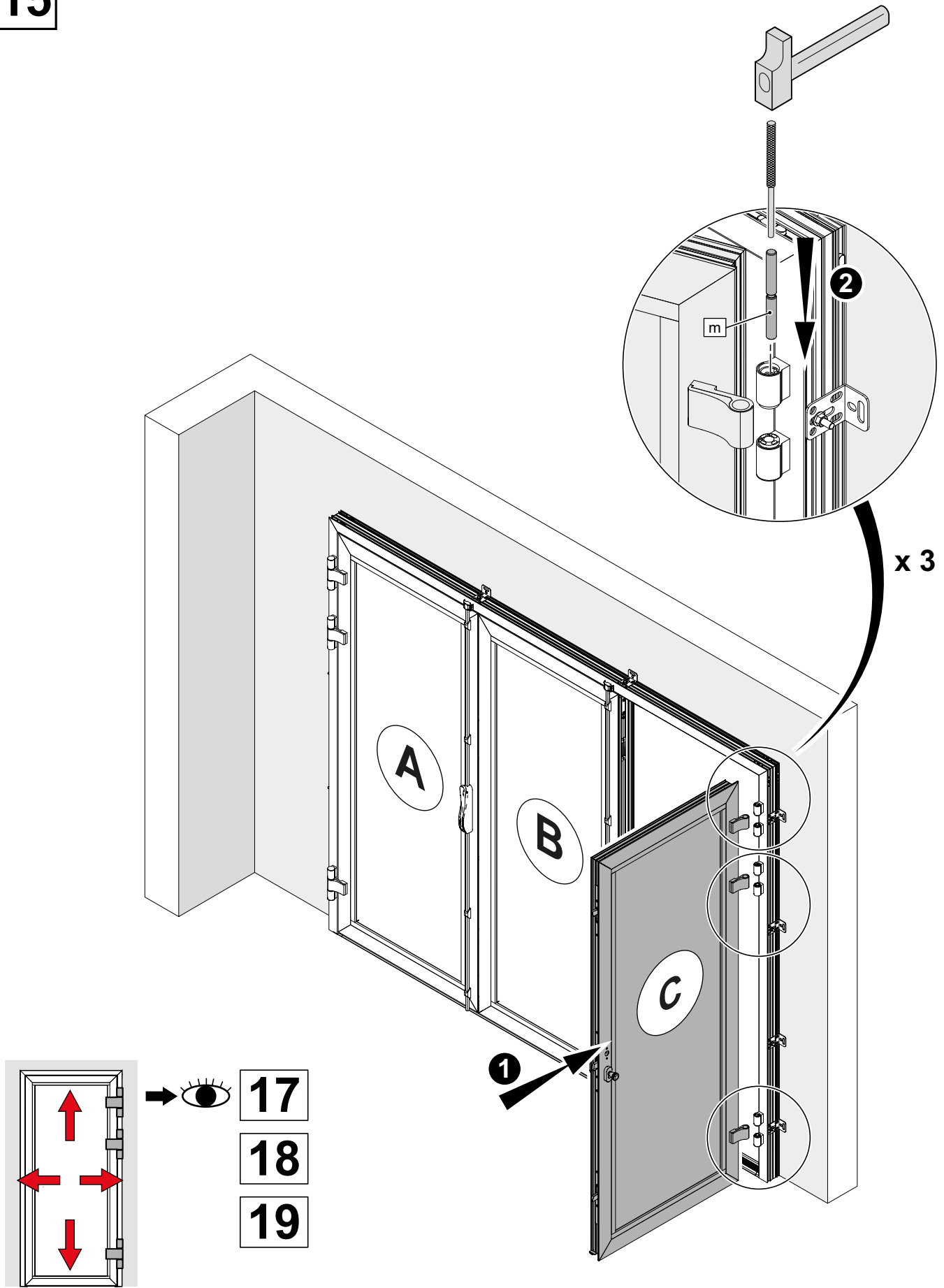

16

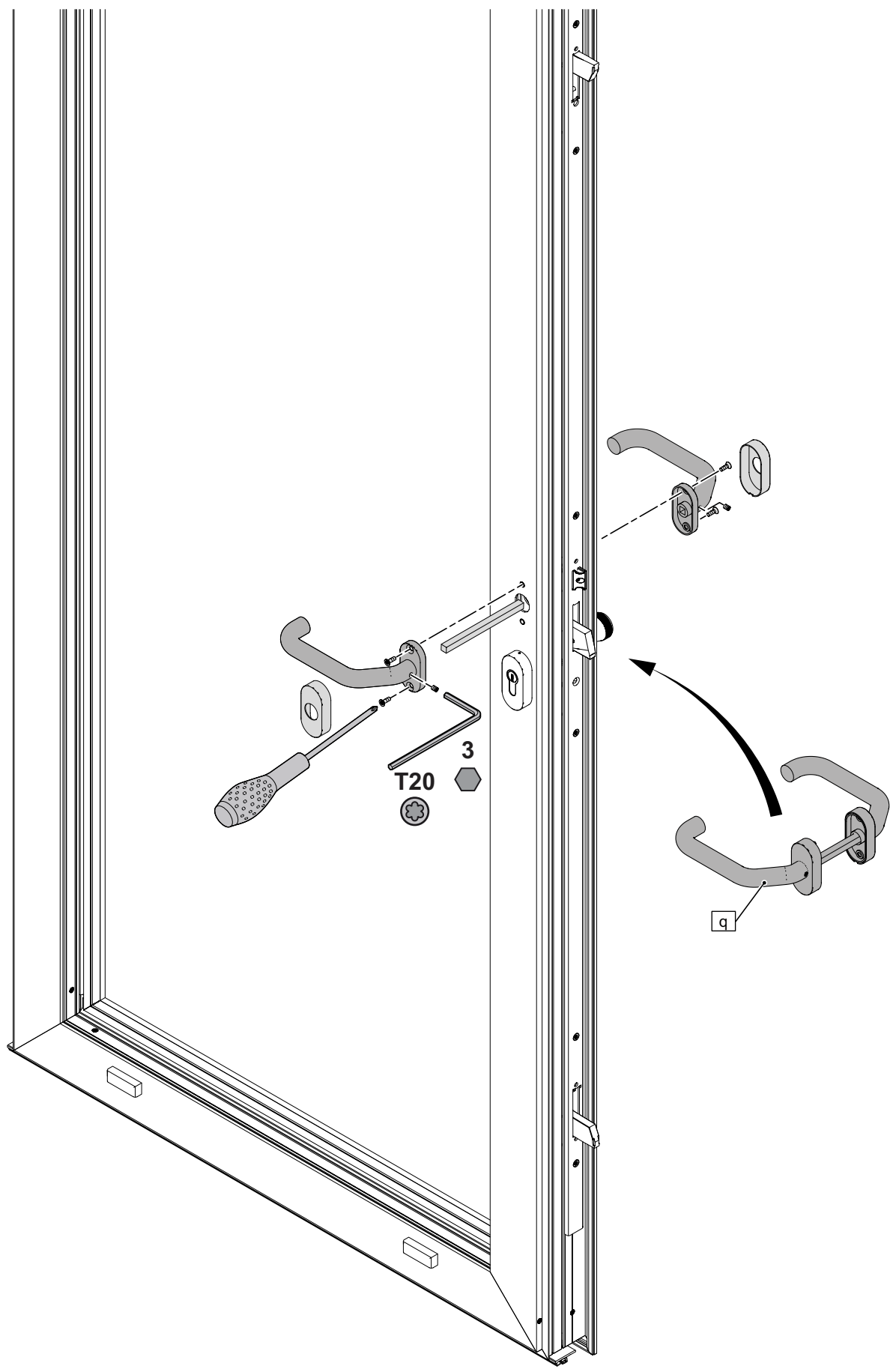

17

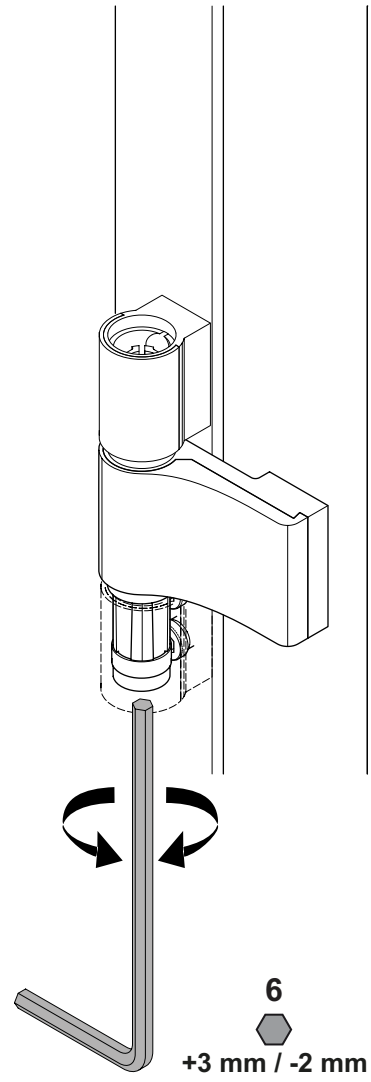
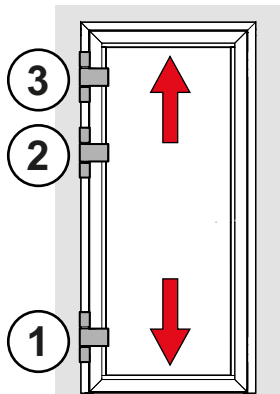

18

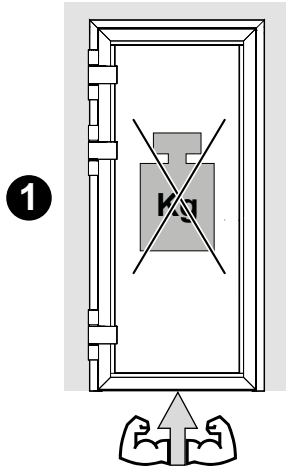
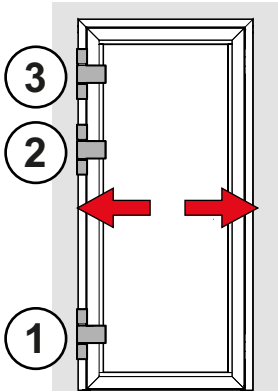

3
+2 mm / -2 mm

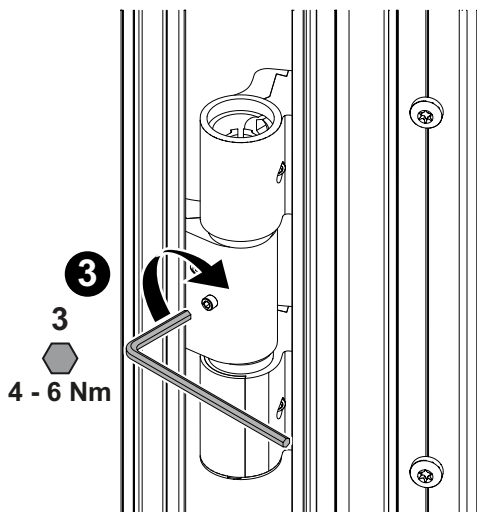
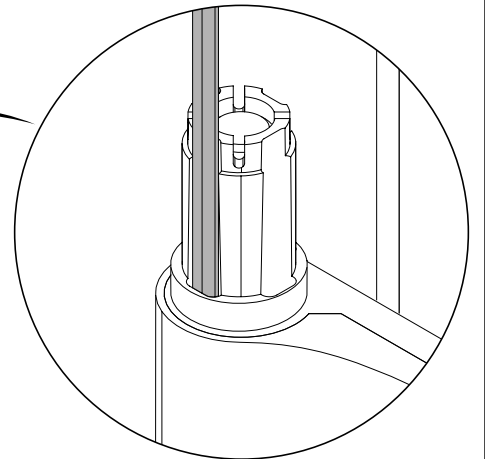
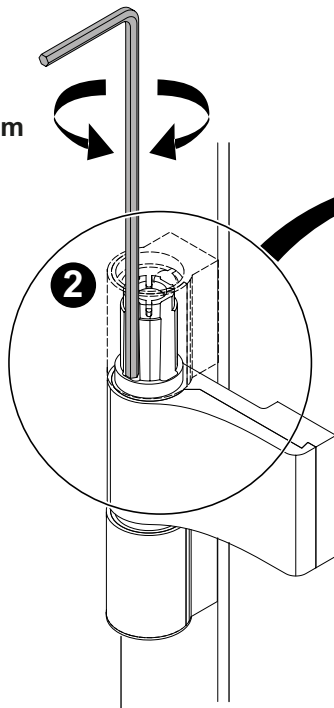

19

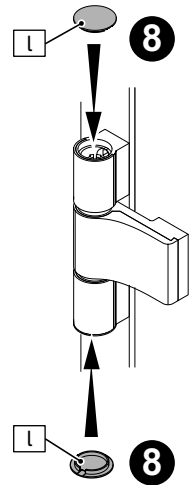
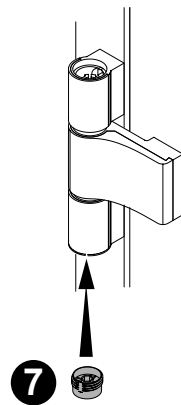
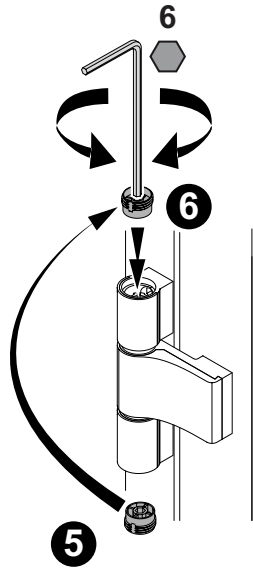
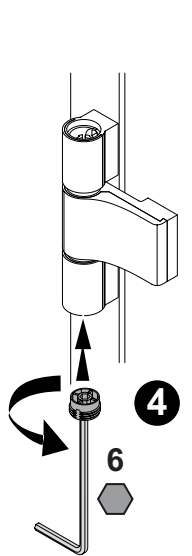
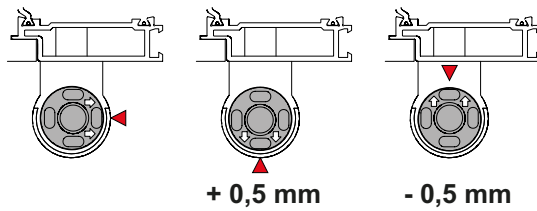
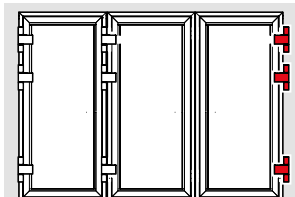
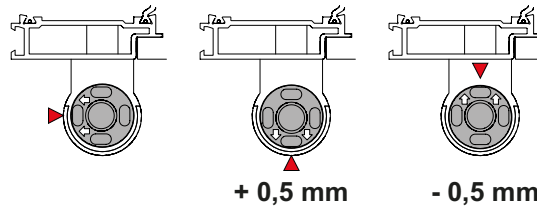
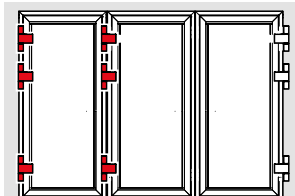
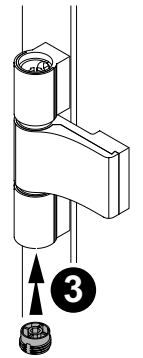
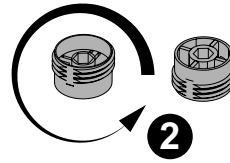
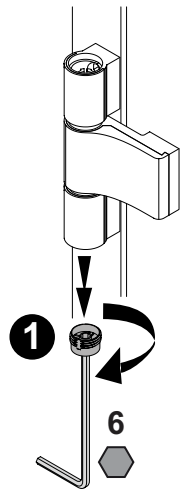
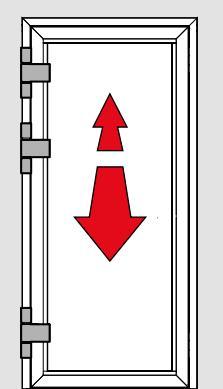

20

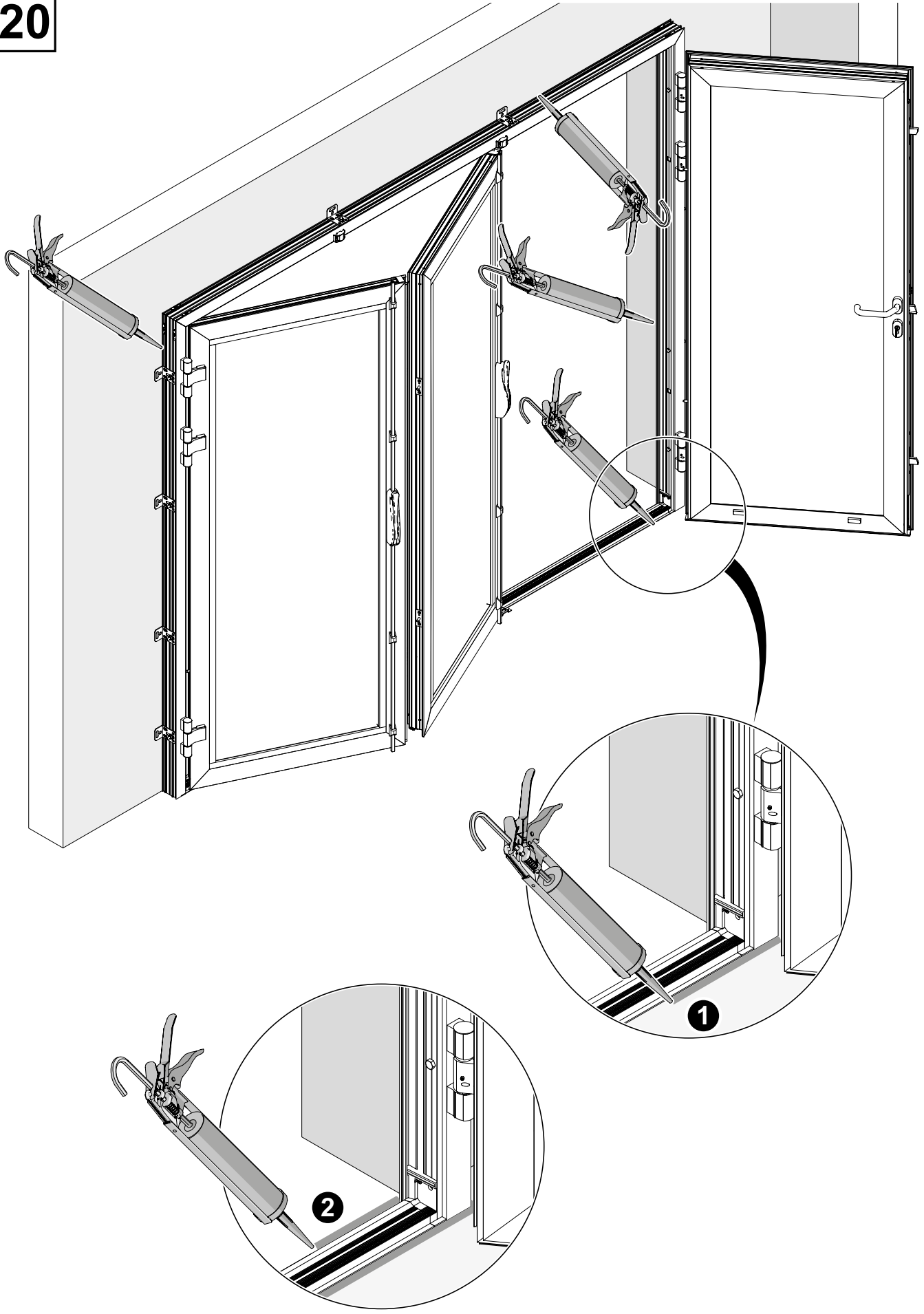

21

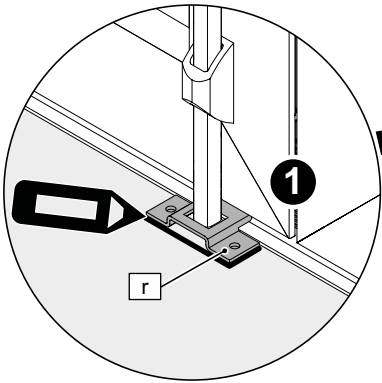

x 2

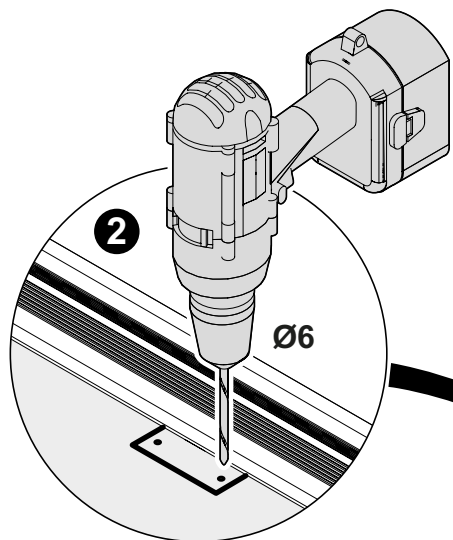
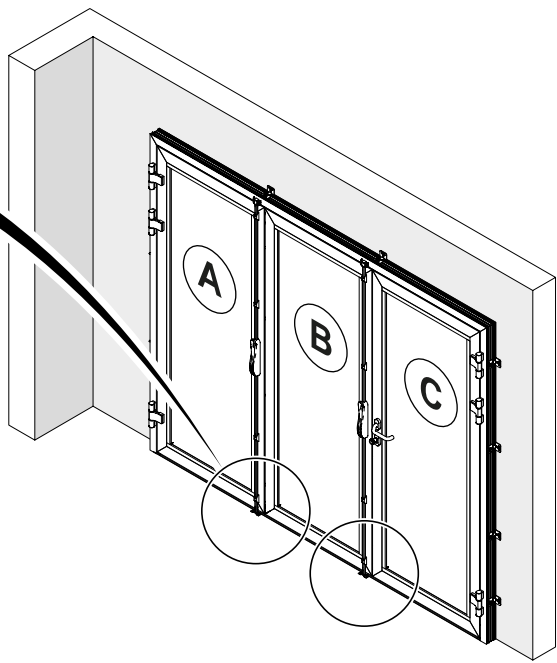

x 2

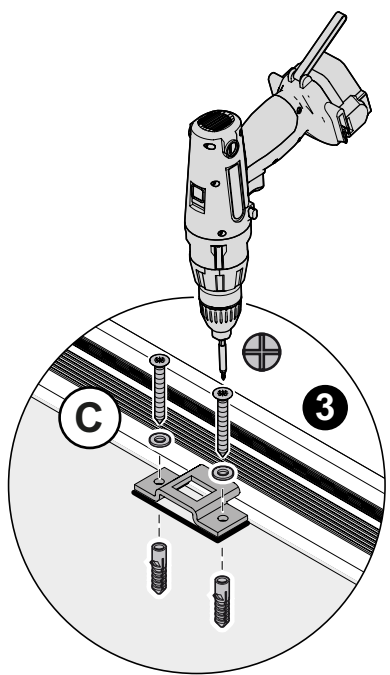
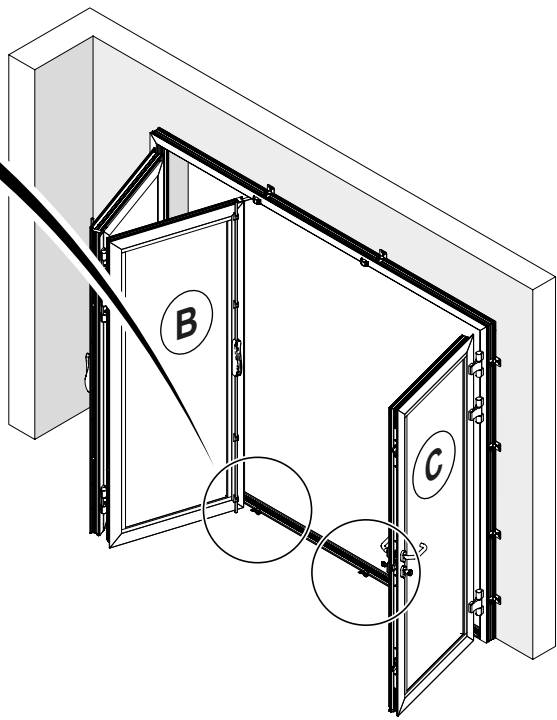

22

Extérieure
Nach Außen
To the outside

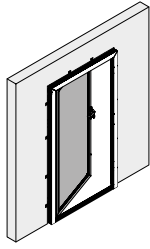

□ E

Si ferme porte
If door closer
Bei Türschliesser

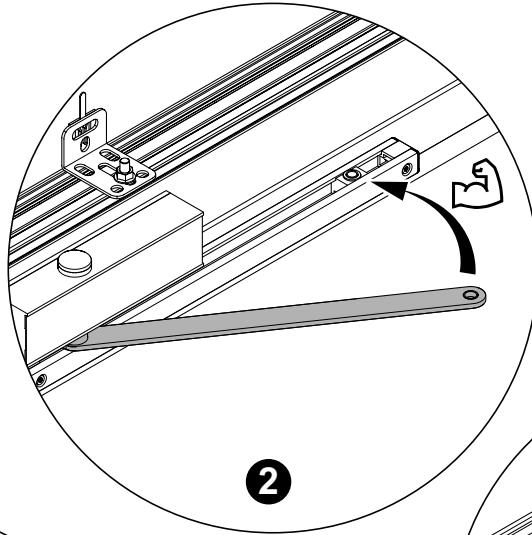

2

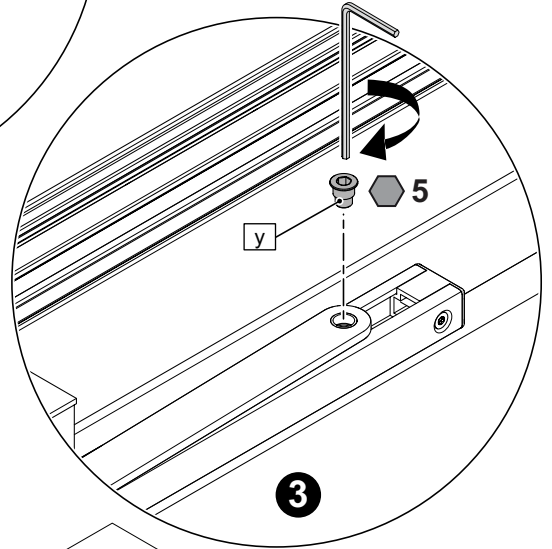

3

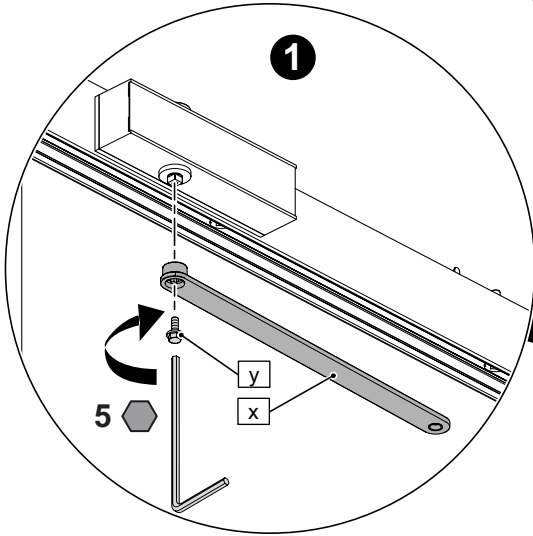

1

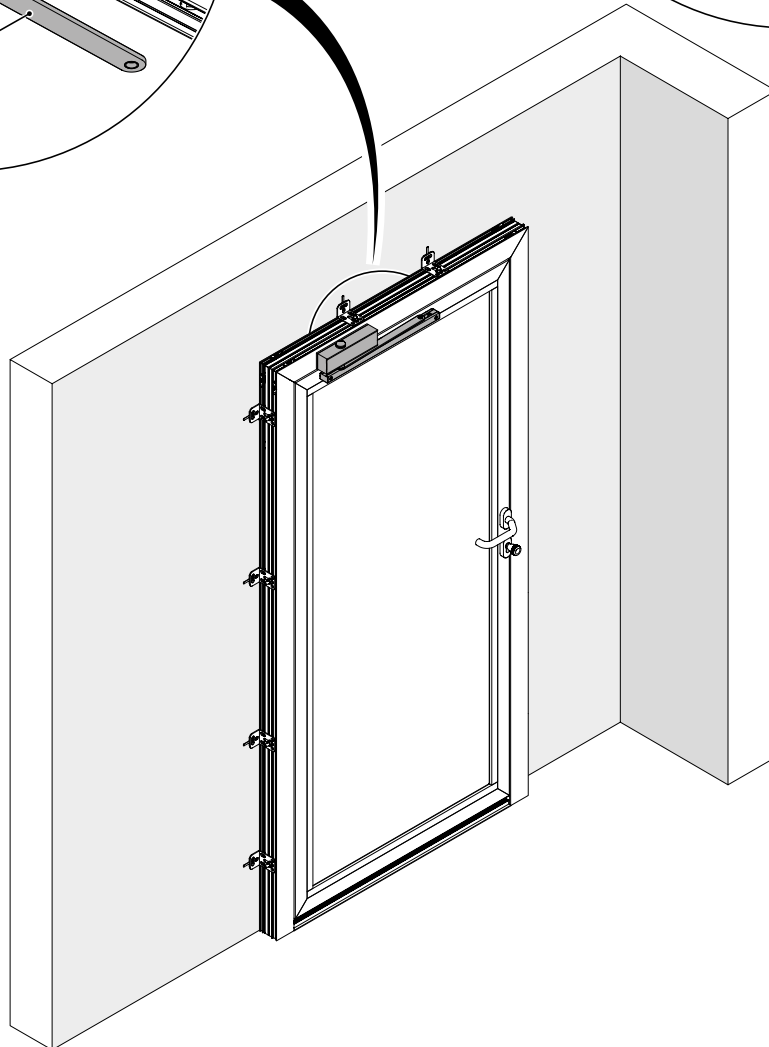

23

Intérieure
Nach Innen
To the inside

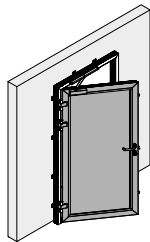

I

Si ferme porte
If door closer
Bei Türschliesser

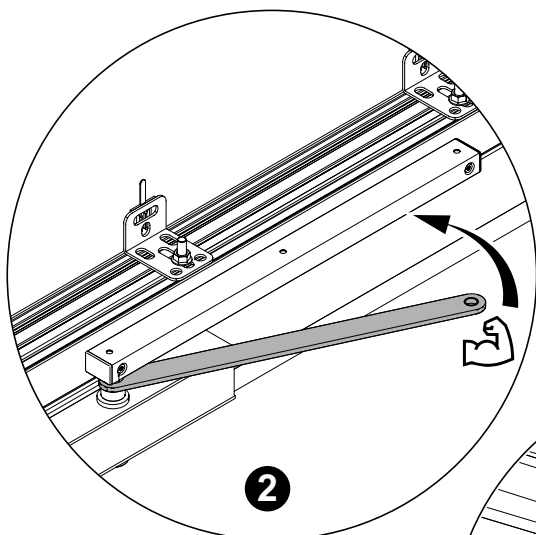

2

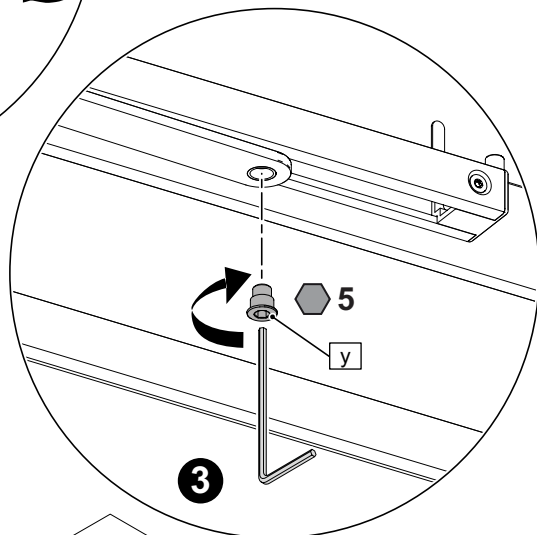

3

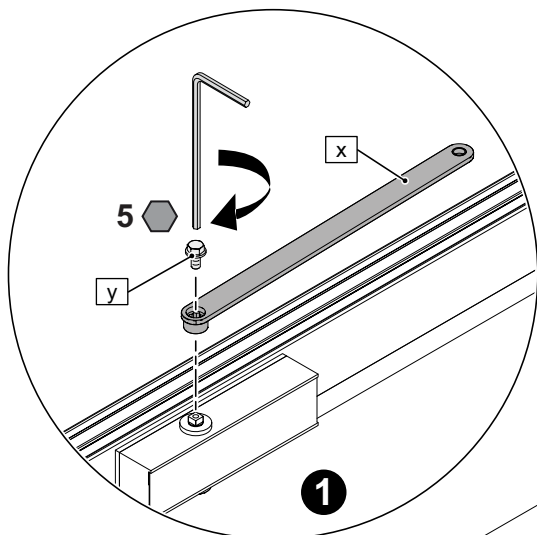

1

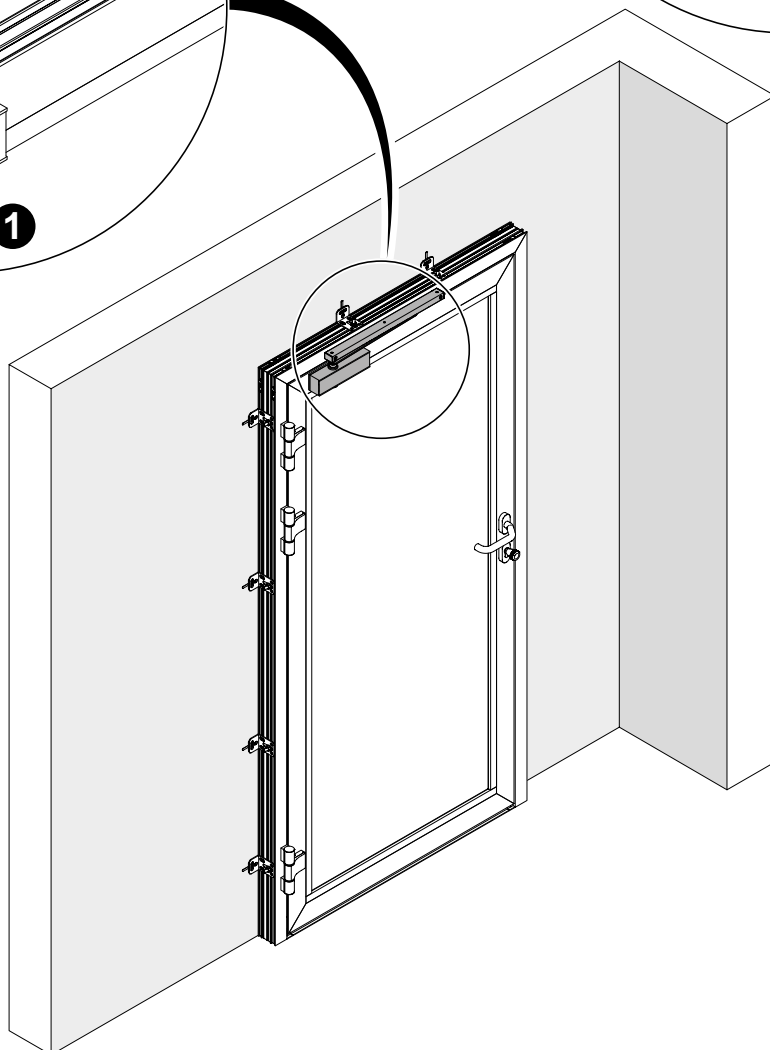

24

Si vérin
lf gas spring
Bei Gasfeder

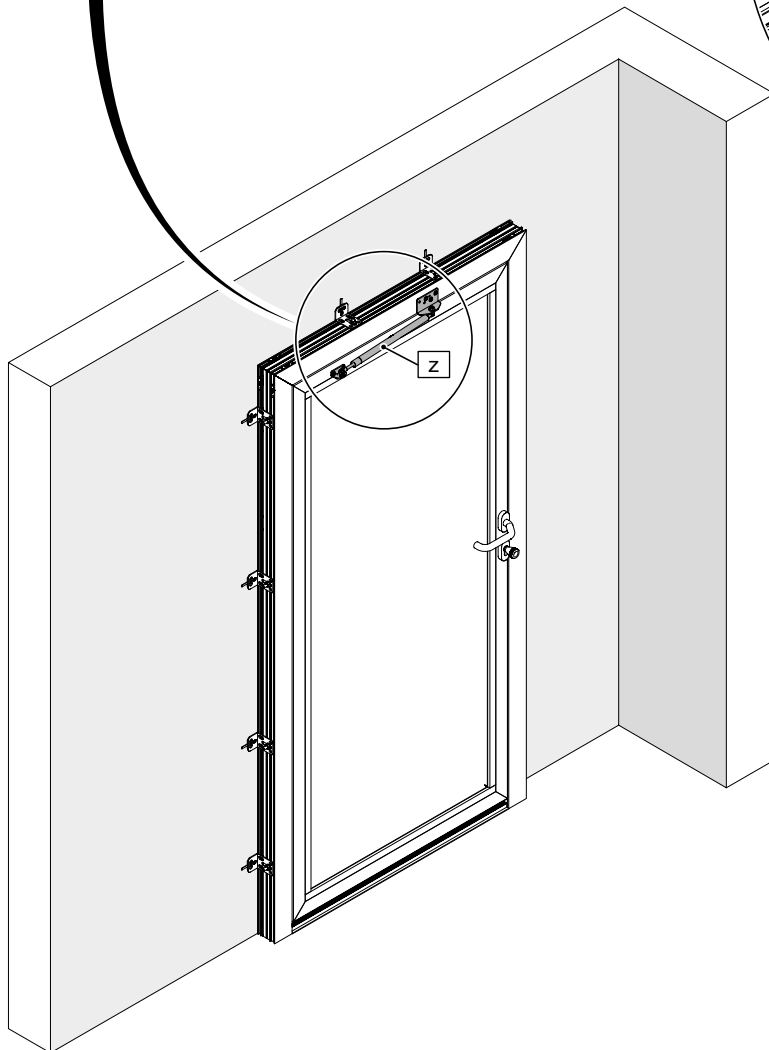
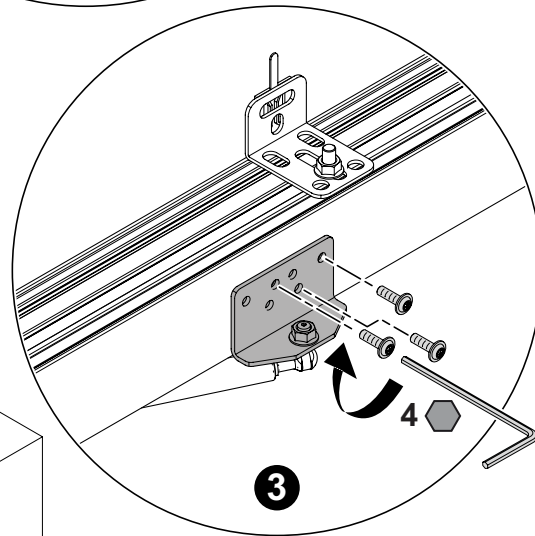
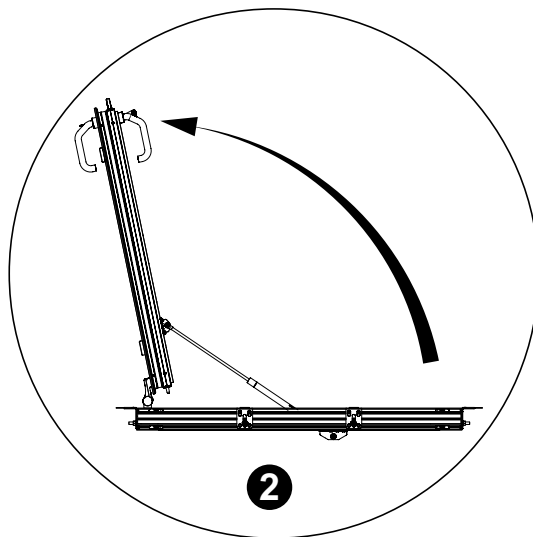
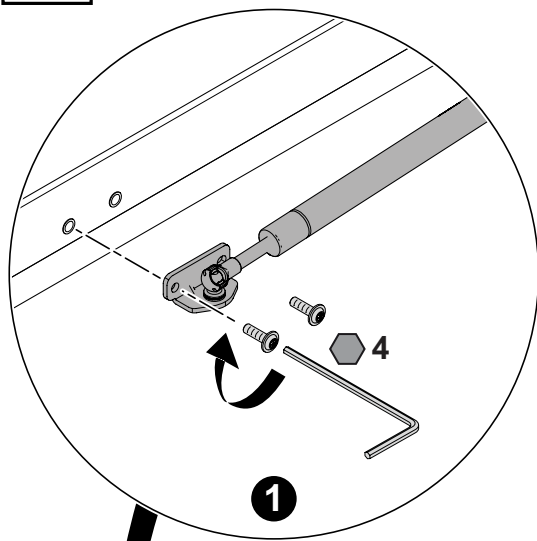

90°	>90°



L'autre entrée principale



Adresses sur quefairedemesdechets.fr