

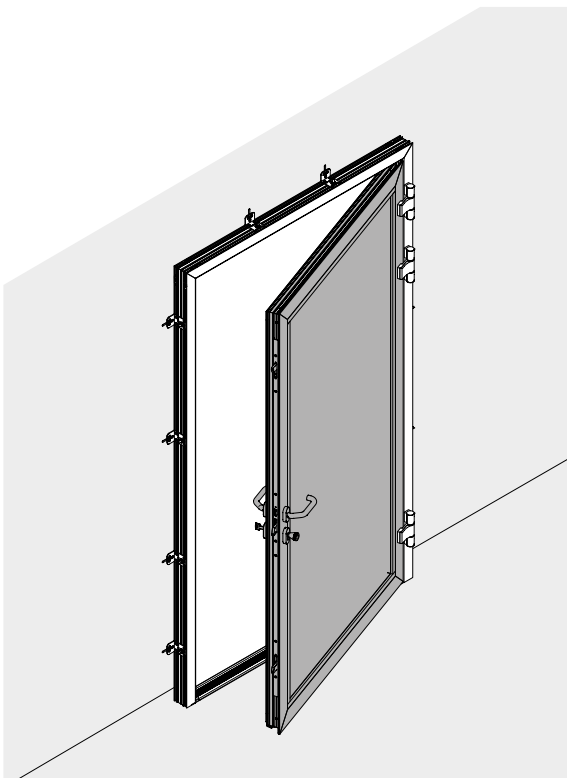

# Notice de pose porte de service

## Einbauanleitung für Nebentür

### Installation instructions for one-piece side door

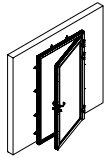
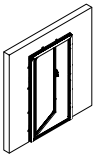
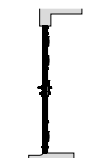
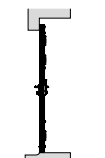
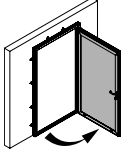
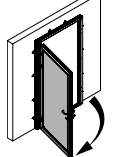

Option / Option / Variante	Oui / Ja / Yes	Non / Nein / No
Vérin Gas spring Gasfeder		
Ferme porte Door closer Türschliesser		
Arrêt de porte à visser Screw-on door stop Türfeststeller zum Anschrauben		
Arrêt de porte à sceller Door stop to seal Türfeststeller zum Versiegeln		
Bloqueur pour ferme porte Door closer blocker Türschließerblocker		

<b>Ouverture</b> <i>Öffnungsrichtung</i> <b>Opening</b>	Intérieure <i>Nach Innen</i> <i>To the inside</i>	Extérieure <i>Nach Außen</i> <i>To the outside</i>
	 <input type="checkbox"/> <b>I</b>	 <input type="checkbox"/> <b>E</b>
<b>Pose</b> <i>Montage Anschlag</i> <b>Mounting stop</b>	Tunnel <i>In der Öffnung</i> <i>Build in</i>	Applique <i>Hinter der Öffnung</i> <i>Build on</i>
	 <input type="checkbox"/> <b>T</b>	 <input type="checkbox"/> <b>A</b>
<b>Tirant</b> <i>Richtung Innen</i> <b>Pulling direction</b>	Droite <i>Rechts</i> <i>Right</i>	Gauche <i>Links</i> <i>Left</i>
	 <input type="checkbox"/> <b>D</b>	 <input type="checkbox"/> <b>G</b>
<b>Configuration / Konfiguration / Configuration :</b>		
<input type="checkbox"/> <input type="checkbox"/> <input type="checkbox"/> →  <b>Pages / Seiten / Pages 2-3</b>		

**IAD**

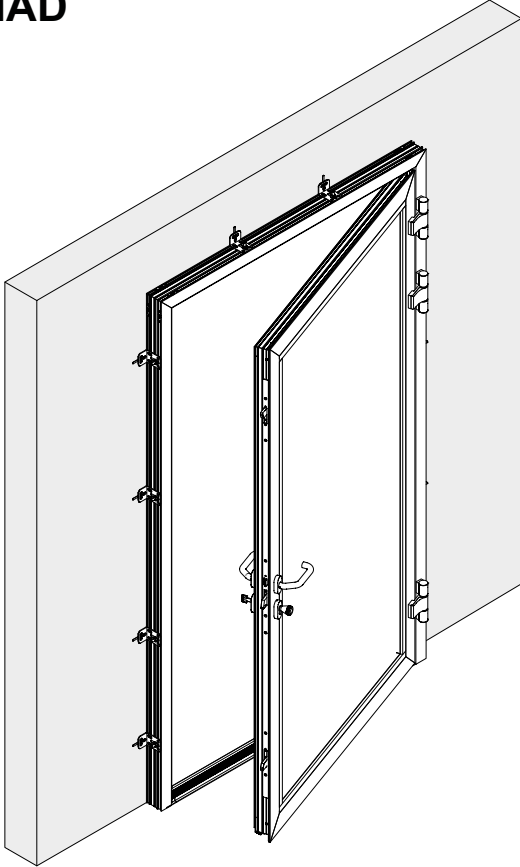

**ITD**

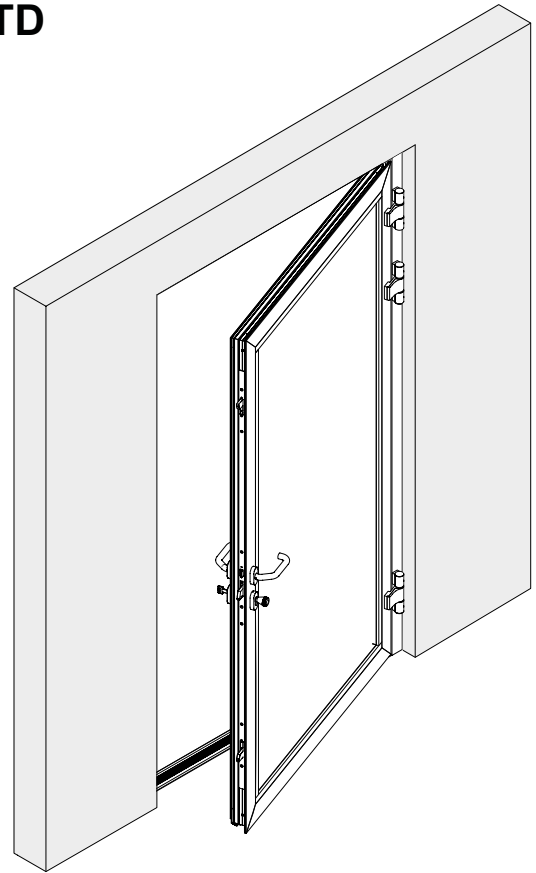

**IAG**

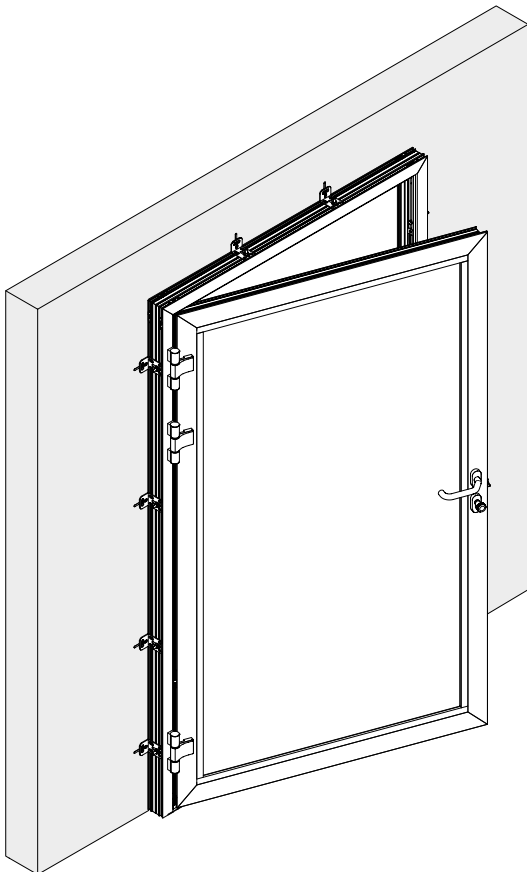

**ITG**

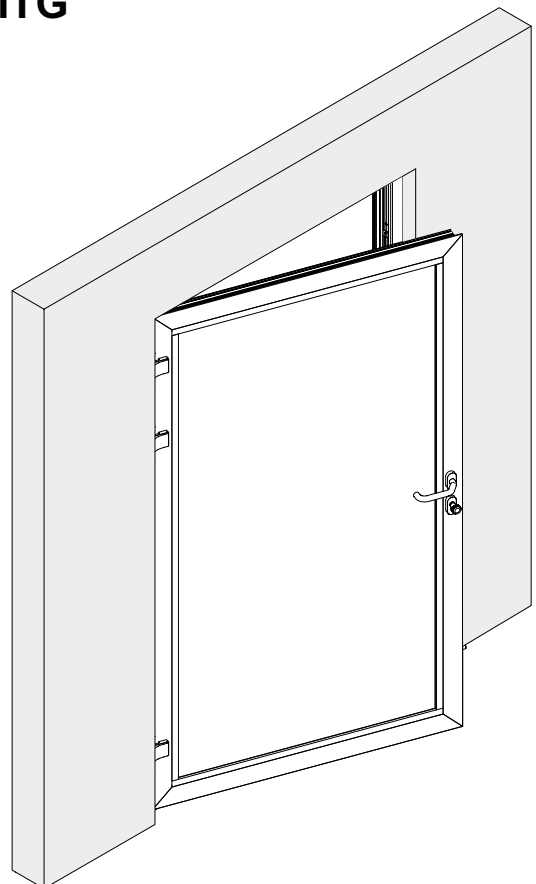

**EAD**

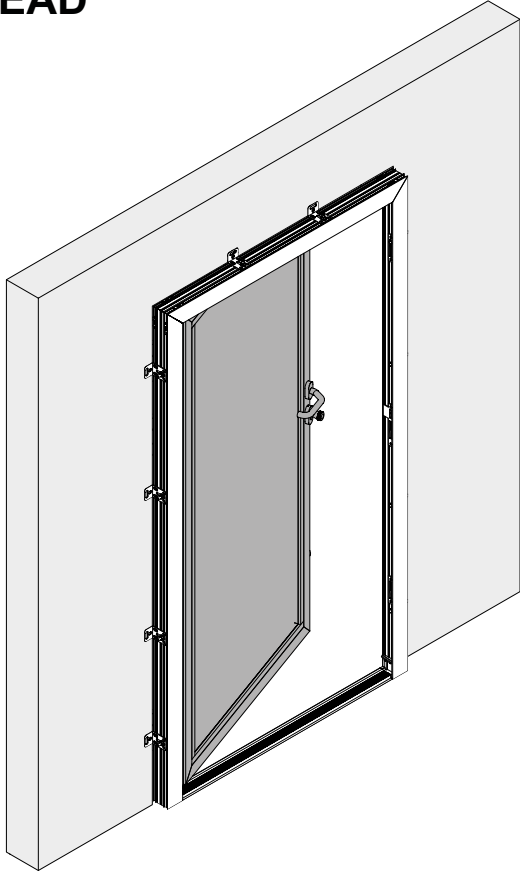

**ETD**

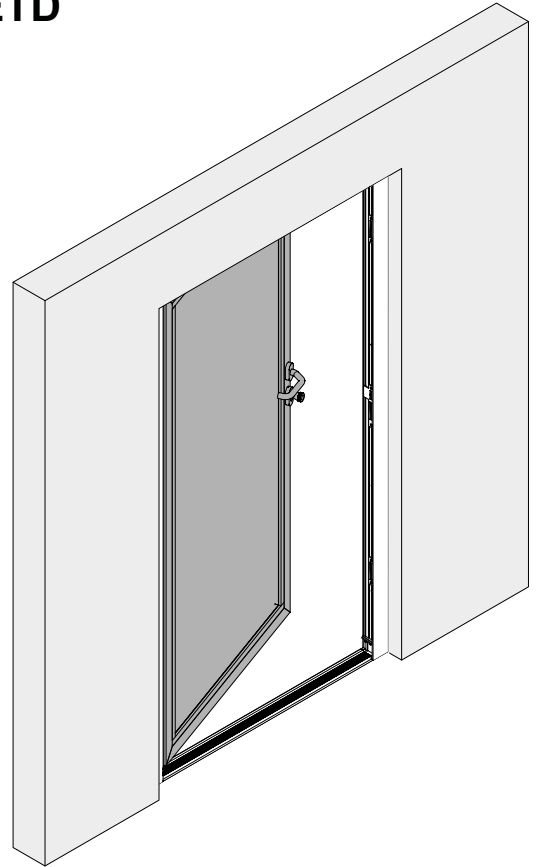







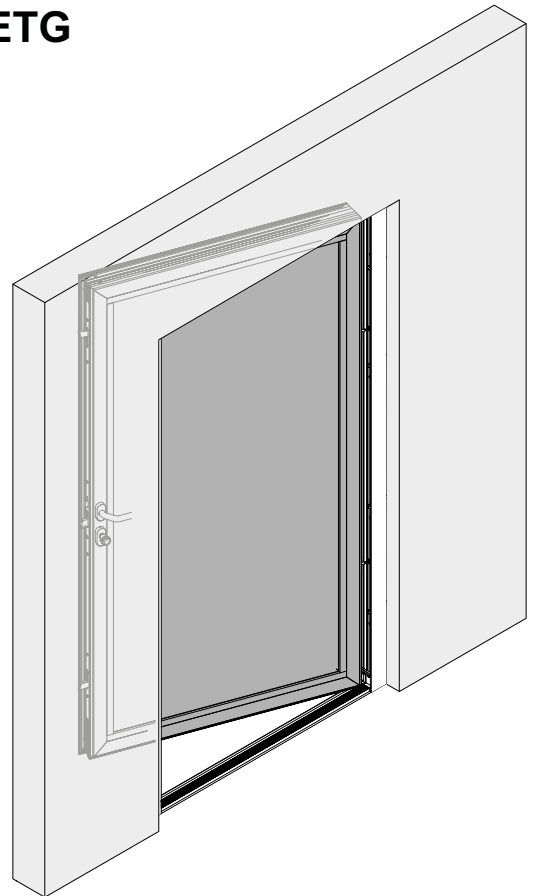



**EAG**

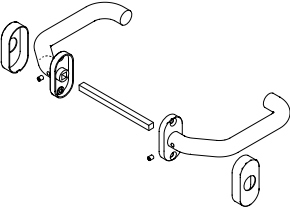

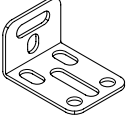
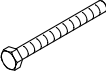
**ETG**

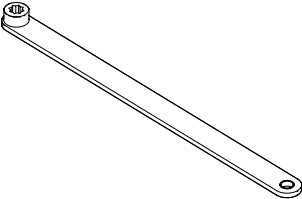

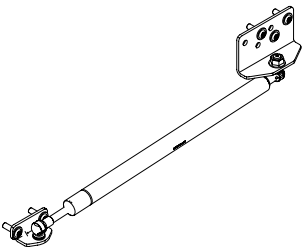
Pièces fournies / Parts supplied / Gelieferte Teile			
<b>l</b>			<b>x6</b>
<b>m</b>			<b>x3</b>
<b>n</b>			<b>x5</b>
<b>p</b>	 M4 x 16		<b>x8</b>
<b>q</b>			<b>x1</b>
<b>s</b>			<b>x10</b>
<b>t</b>		Si fixation applique If build in Bei Option hinter der Öffnung	<b>x10</b>
<b>u</b>	 M8 x 80	Si fixation applique If build in Bei Option hinter der Öffnung	<b>x8</b>
<b>v</b>	 M8	Si fixation applique If build in Bei Option hinter der Öffnung	<b>x10</b>
<b>w</b>	 M8 x 20	Si fixation applique If build in Bei Option hinter der Öffnung	<b>x2</b>
<b>x</b>		Si option ferme porte If door closer option Bei Option Türschliesser	<b>x1</b>
<b>y</b>		Si option ferme porte If door closer option Bei Option Türschliesser	<b>x1</b>
<b>z</b>		Si option vérin If gas spring option Bei Option Gasfeder	<b>x1</b>

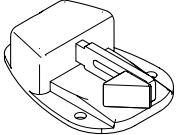
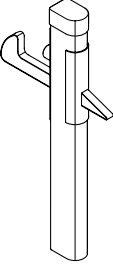
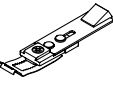
Pièces fournies / Parts supplied / Gelieferte Teile			
<b>aa</b>		Si option arrêt de porte à visser If screw-on door stop option Bei Option Türfeststeller zum Anschrauben	<b>x1</b>
<b>bb</b>		Si option arrêt de porte à sceller If door stop to seal option Bei Option Türstopper zum Versiegeln	<b>x1</b>
<b>cc</b>		Si option bloqueur pour ferme porte If door closer blocker option Bei Option Türschließerblocker	<b>x1</b>
<b>dd</b>	<b>Notice de montage Installation instruction Montageanleitung</b>	<b>NFF16596_C</b>	<b>x1</b>









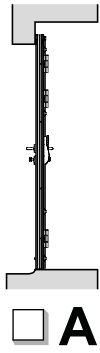

1

Applique  
Hinter der Öffnung  
Build on





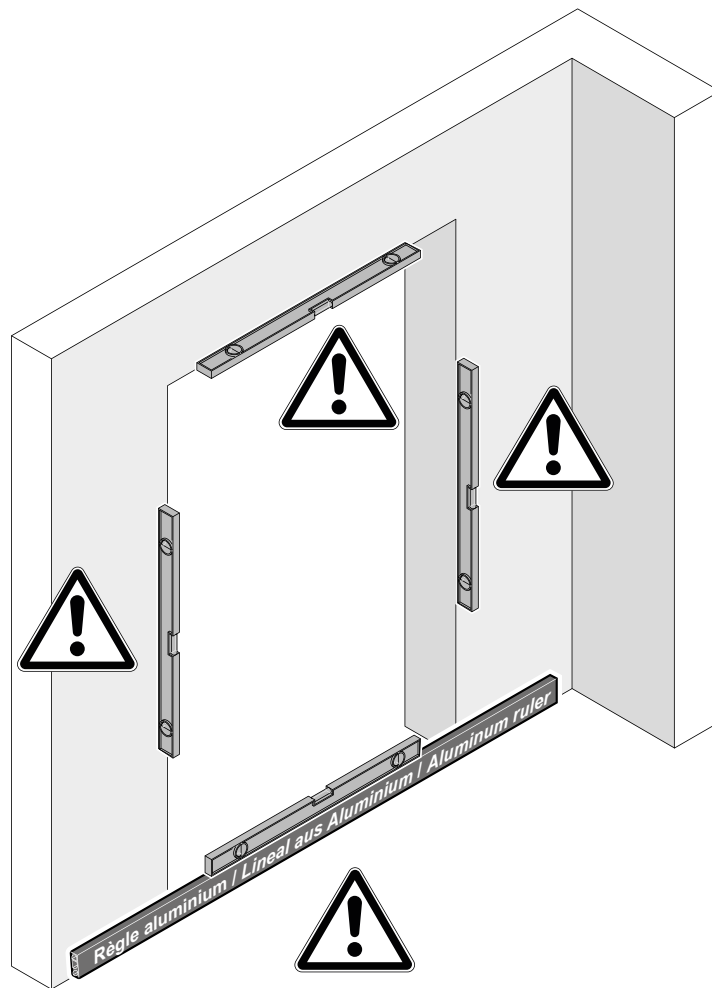

-  (FR) Surfaces planes, de niveau et d'aplomb
-  (DE) Flächen müssen eben und lotrecht sein
-  (GB) Surfaces must be flat and plumb

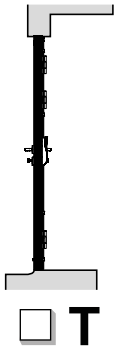

2

Tunnel  
In der Öffnung  
Build in



-  **FR** Surfaces planes,  
de niveau et d'aplomb
-  **DE** Flächen müssen eben  
und lotrecht sein
-  **GB** Surfaces must be flat  
and plumb

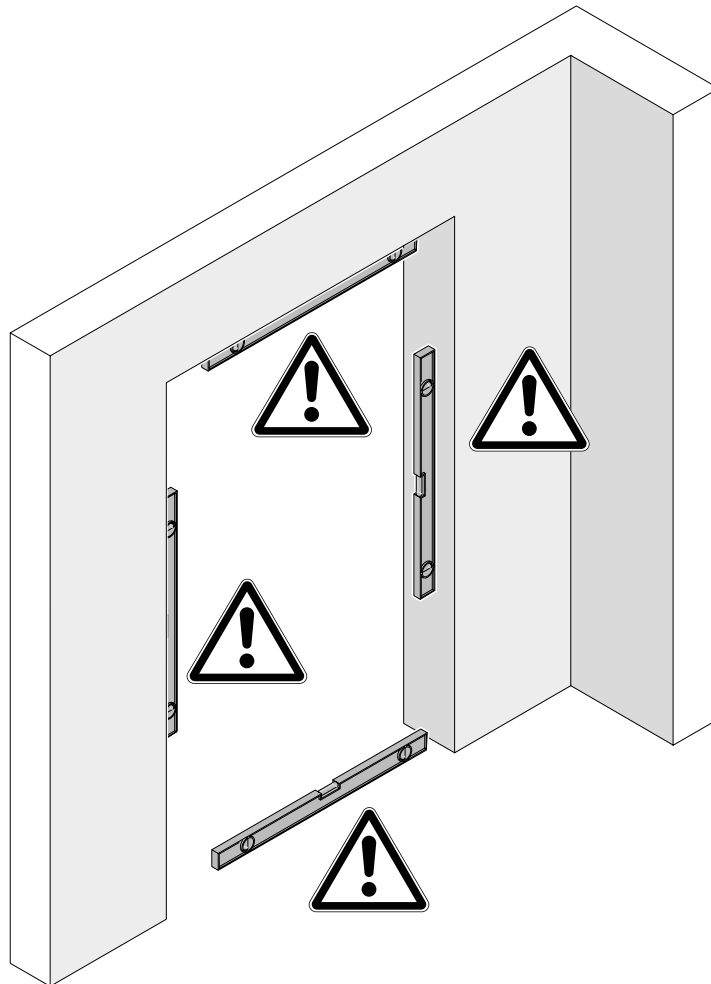

**3**

Applique  
Hinter der Öffnung  
Build on

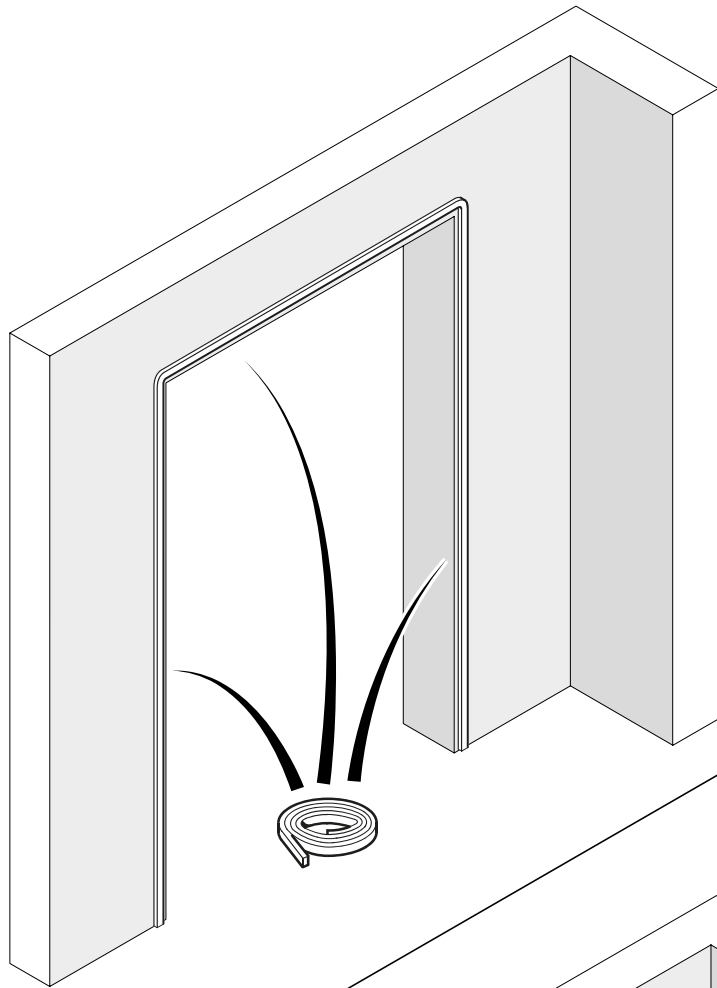
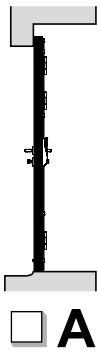

Tunnel  
In der Öffnung  
Build in

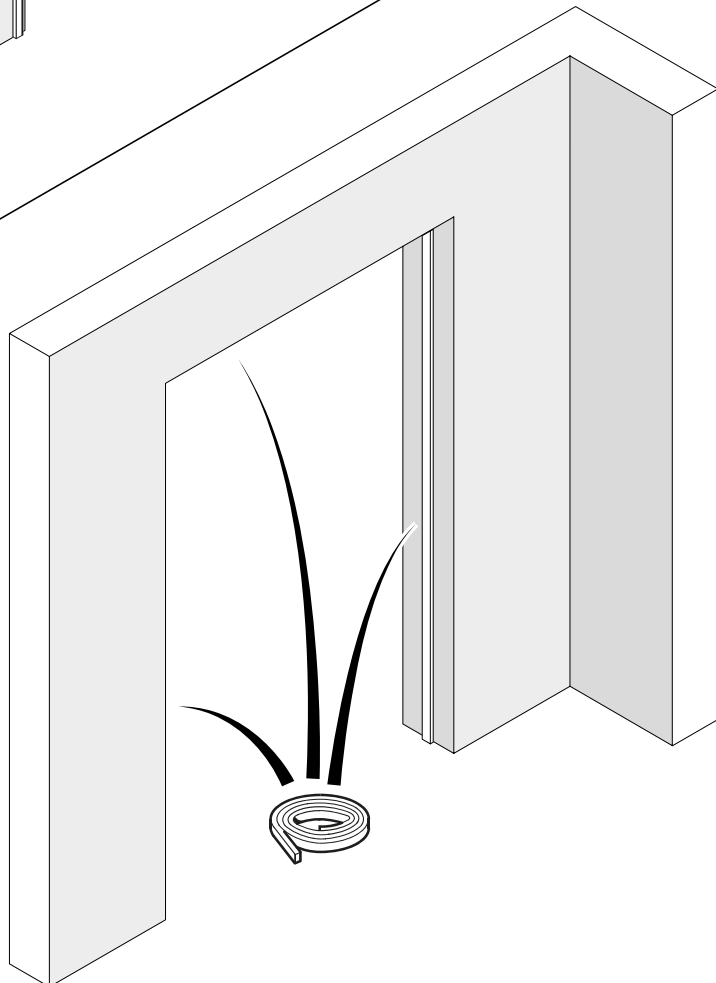
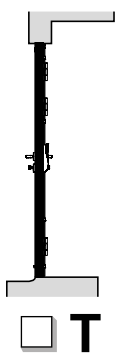

4

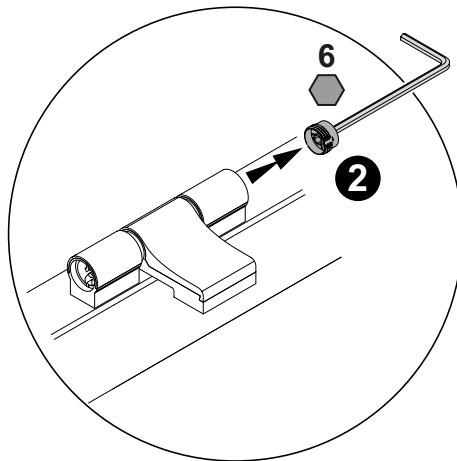
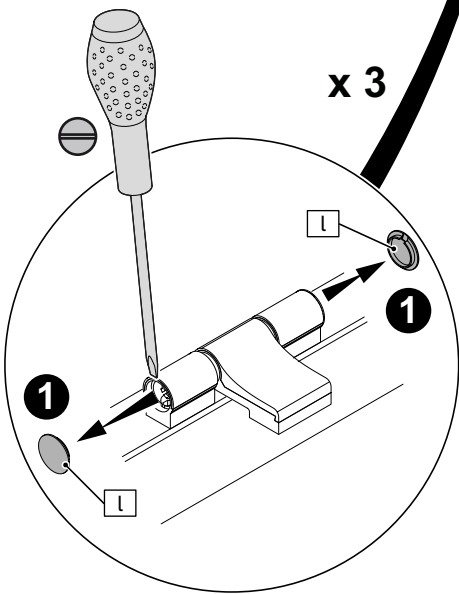
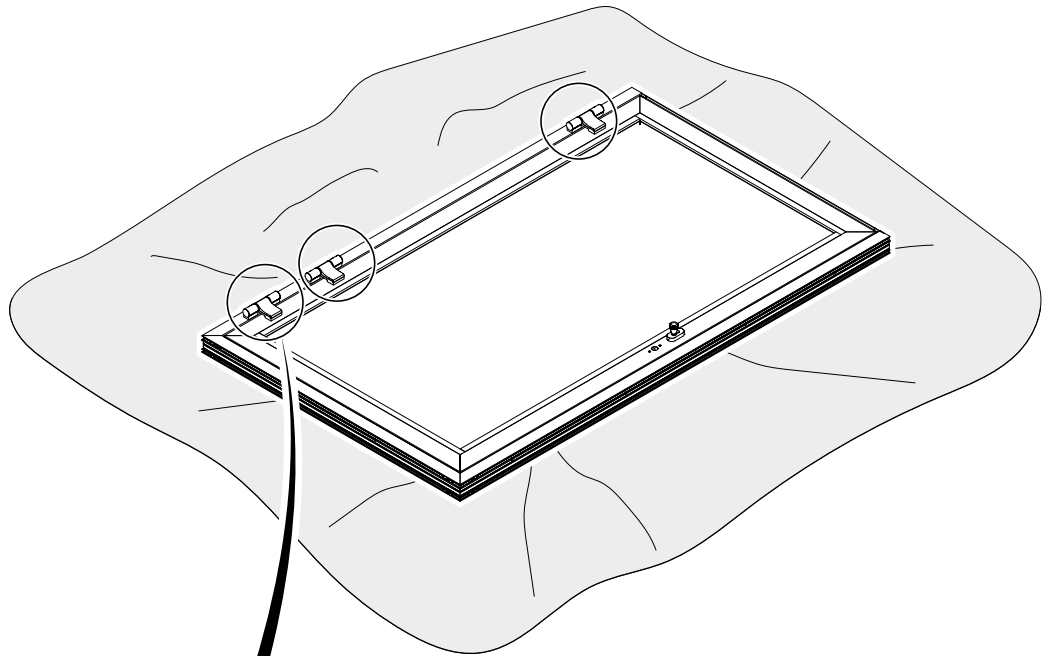

5

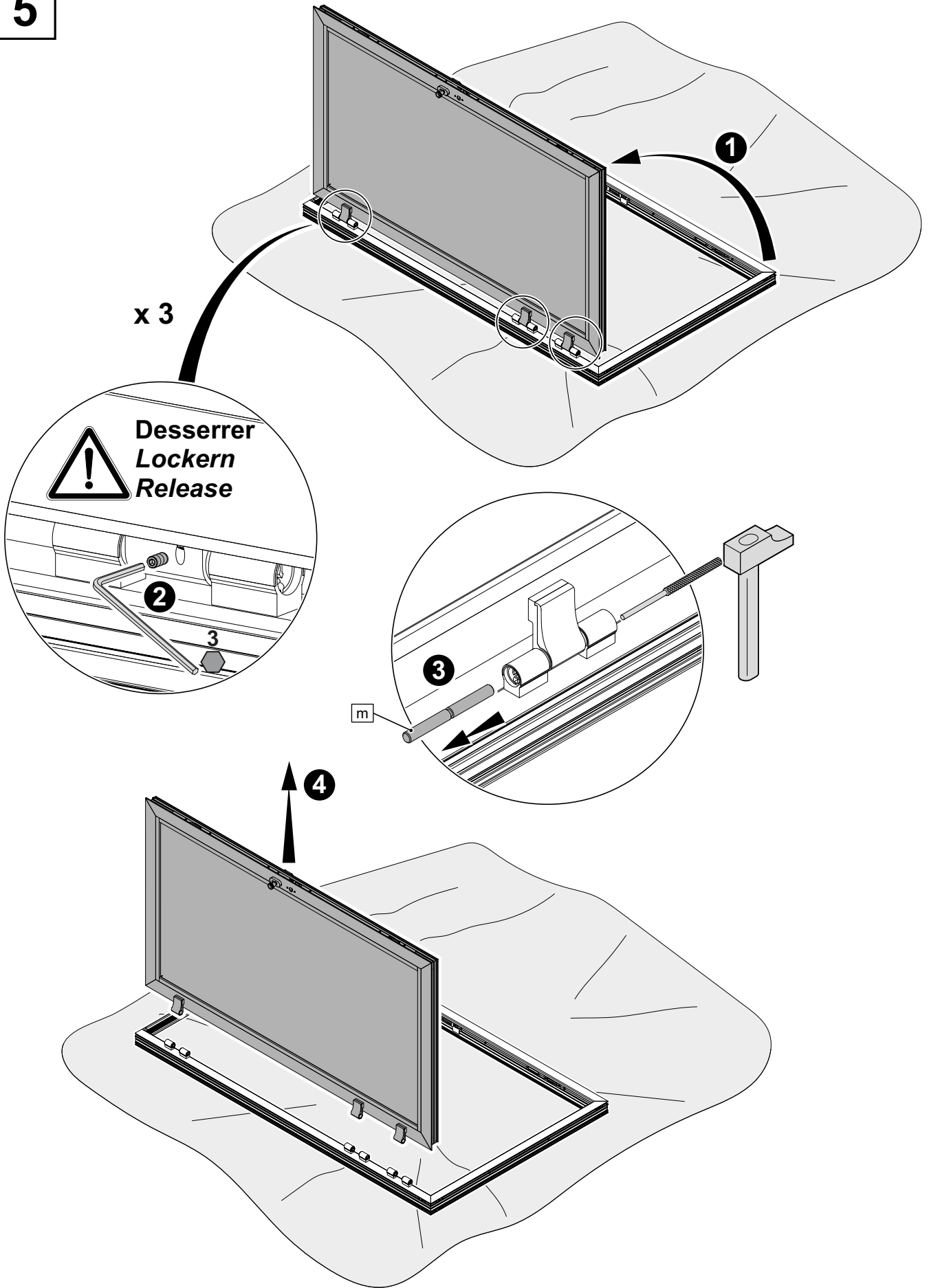

**6**

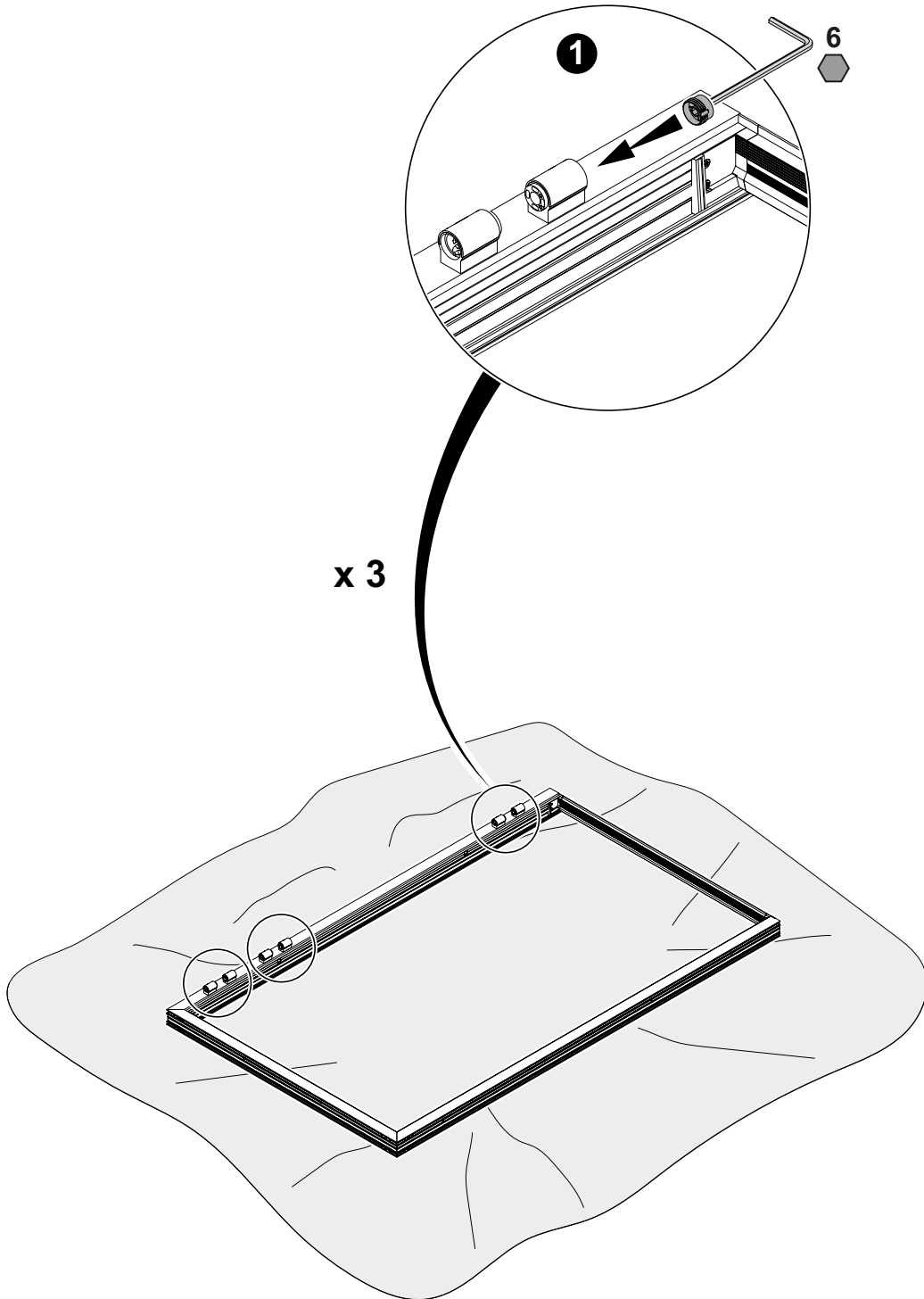

7

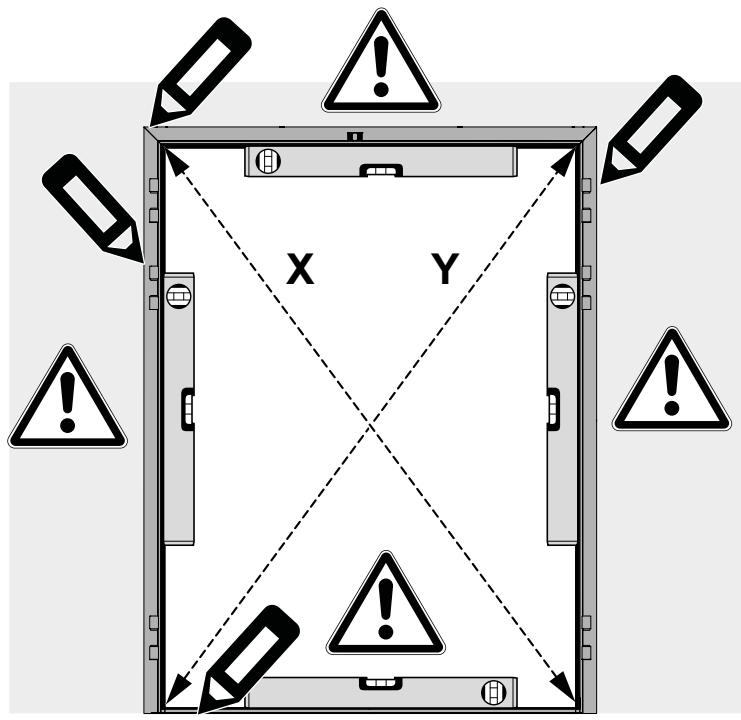

  $X=Y$



8

Applique  
Hinter der Öffnung  
Build on

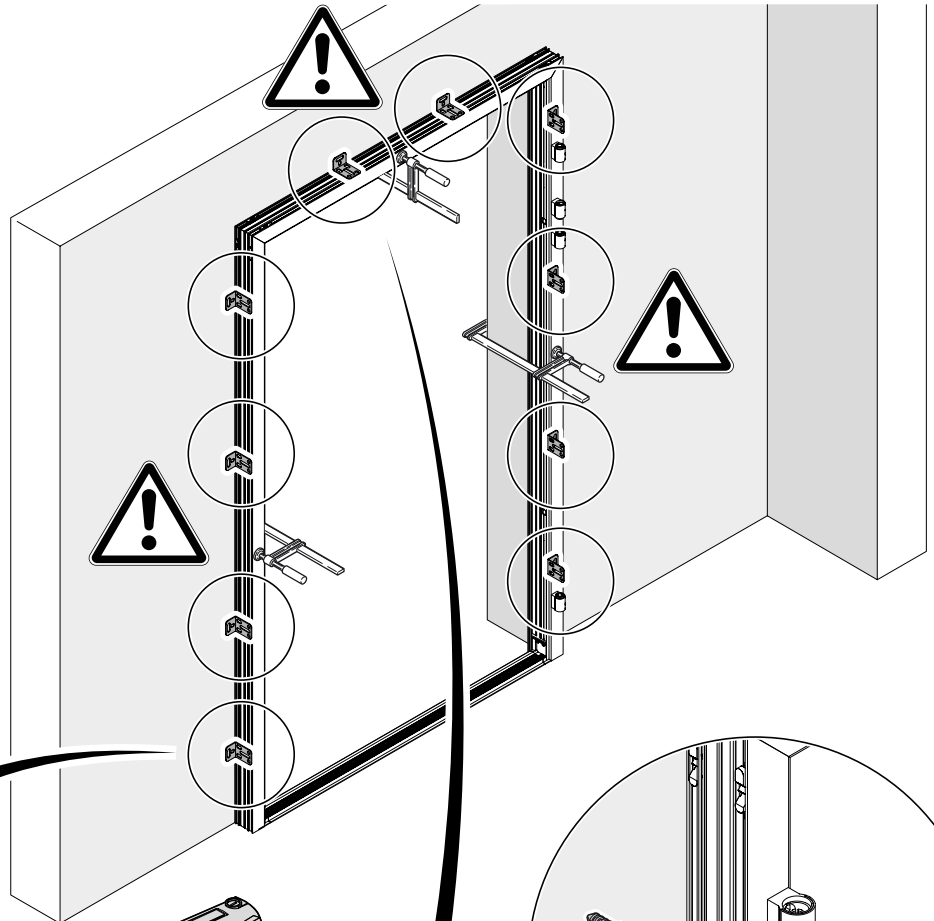
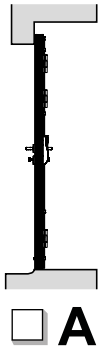

x 8

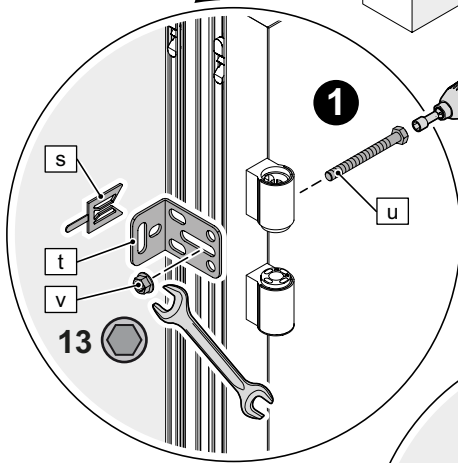

1

13

x 2

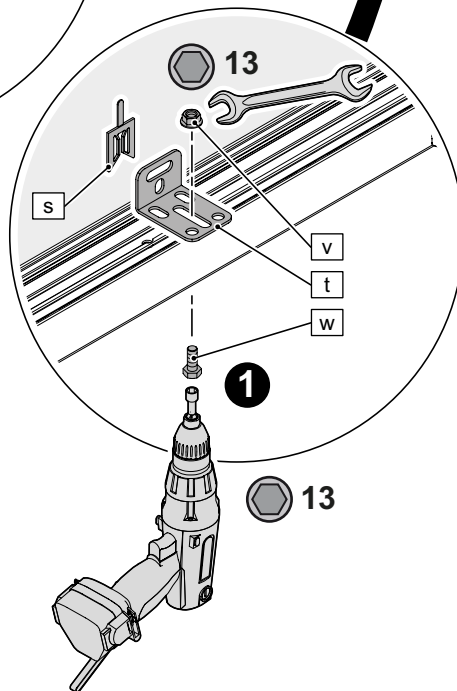

1

13

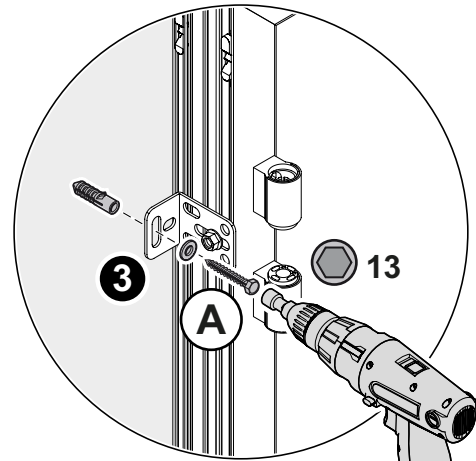

3

A

13

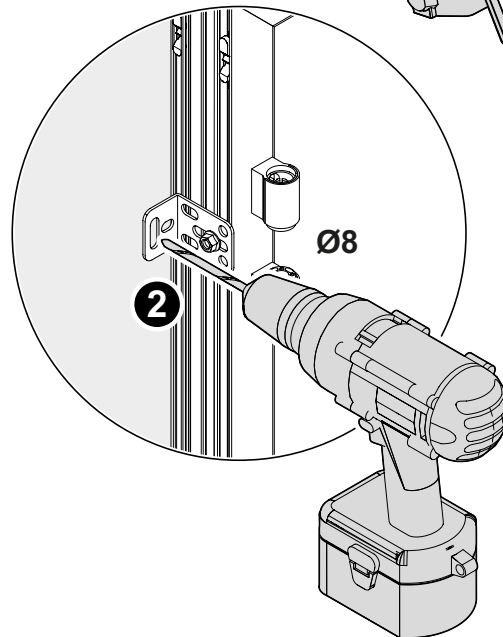

2

Ø8

9

Tunnel  
In der Öffnung  
Build in

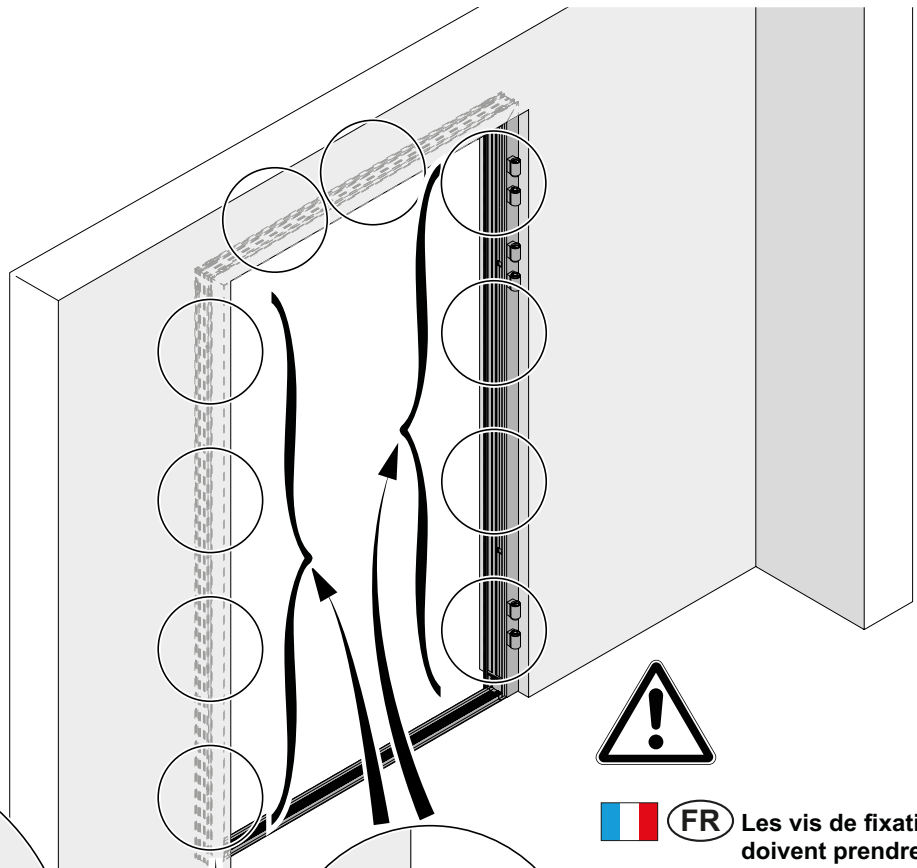
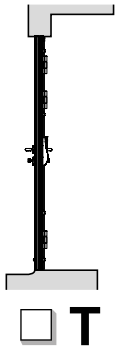

 (FR) Les vis de fixation doivent prendre les 2 parois des profils

 (DE) Die Befestigungsschrauben müssen die 2 Seiten des Profils greifen

 (GB) The fixing screws must take the 2 walls of the profiles

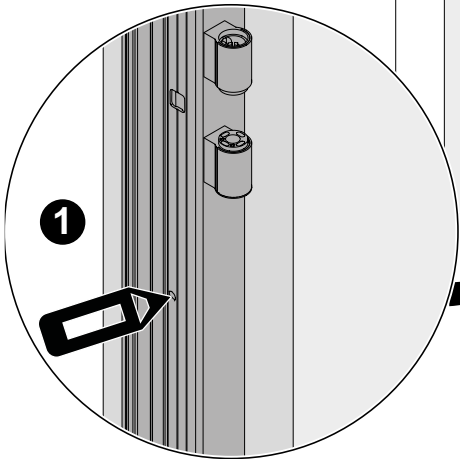

x 10

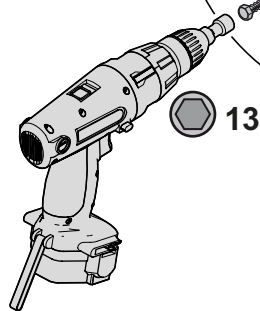
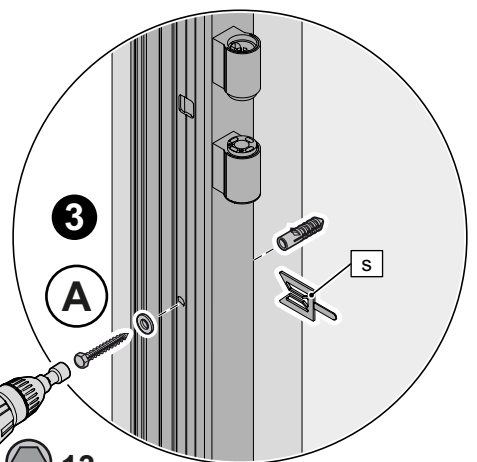
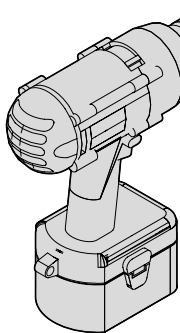
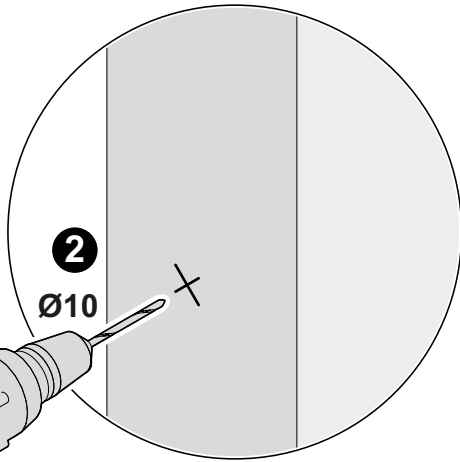
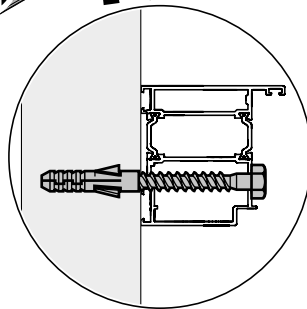

10

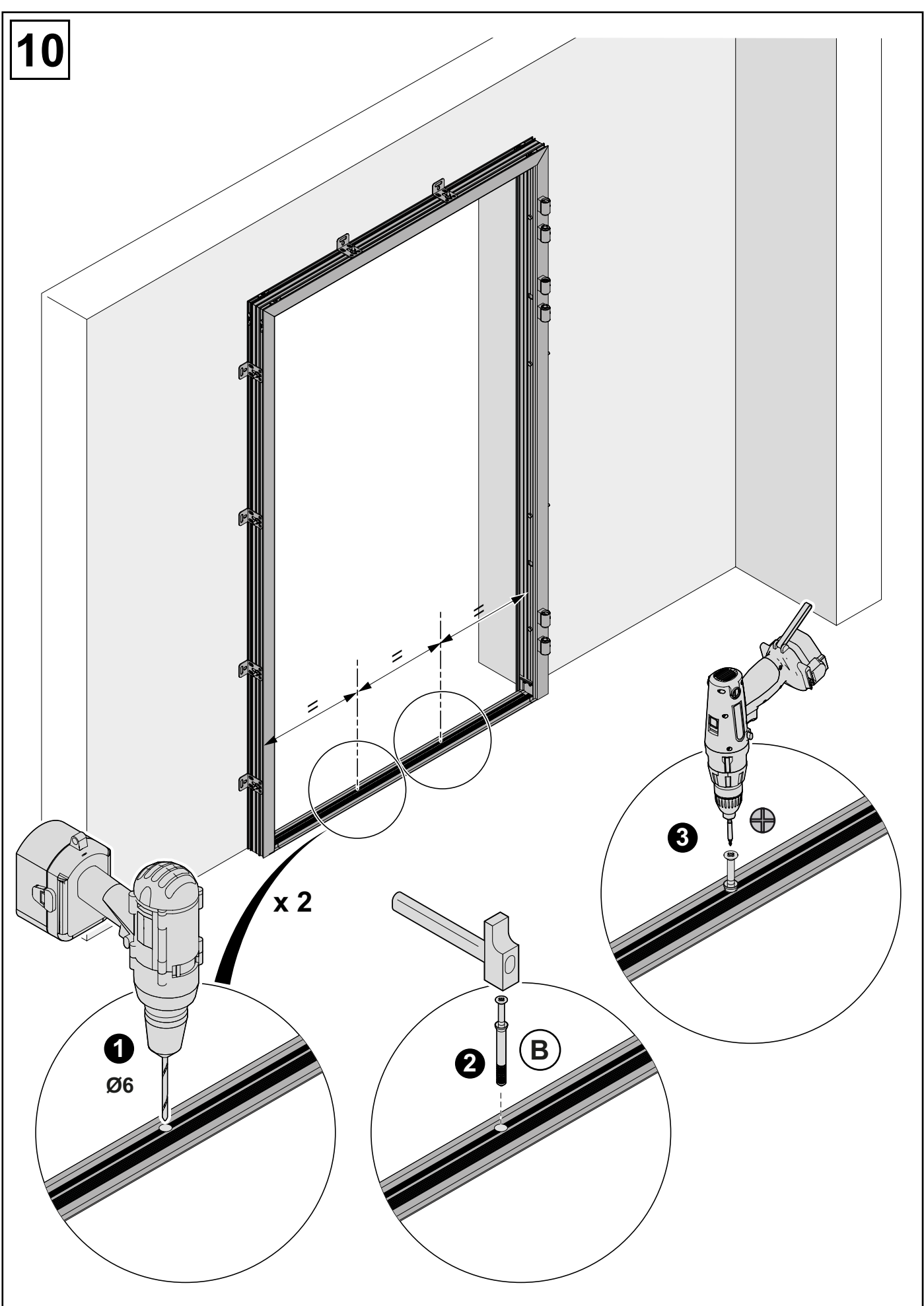

11

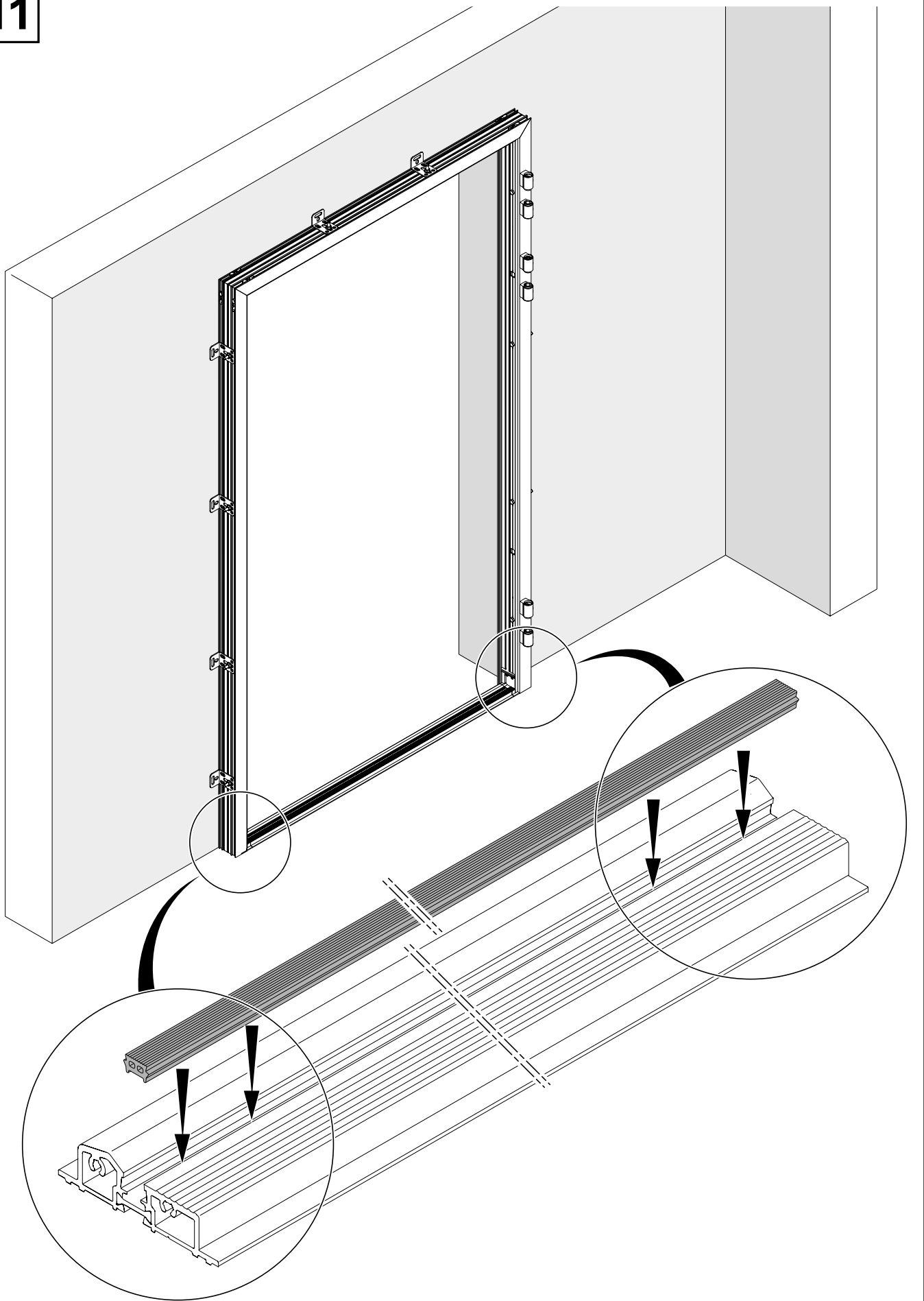

**12**

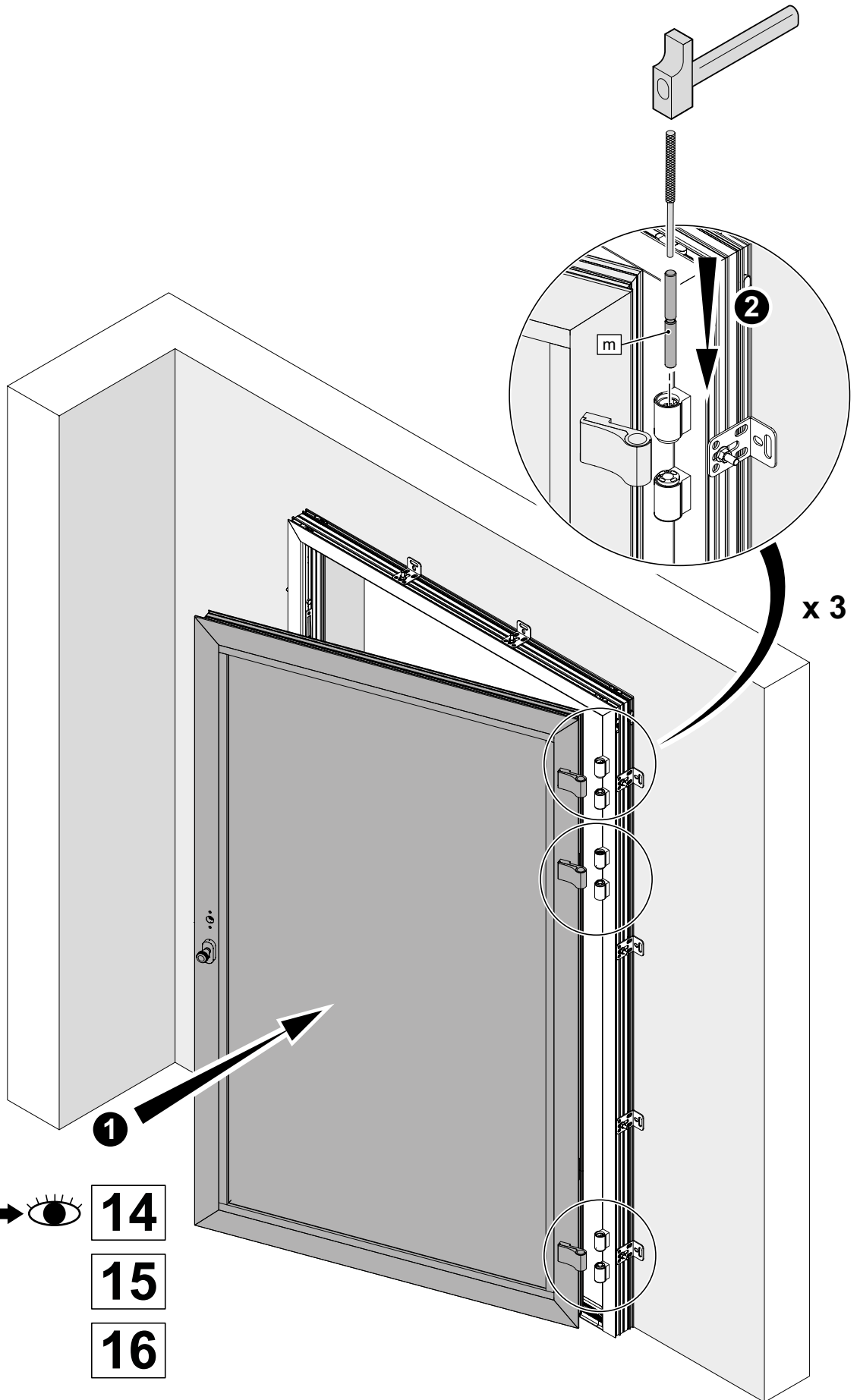

13

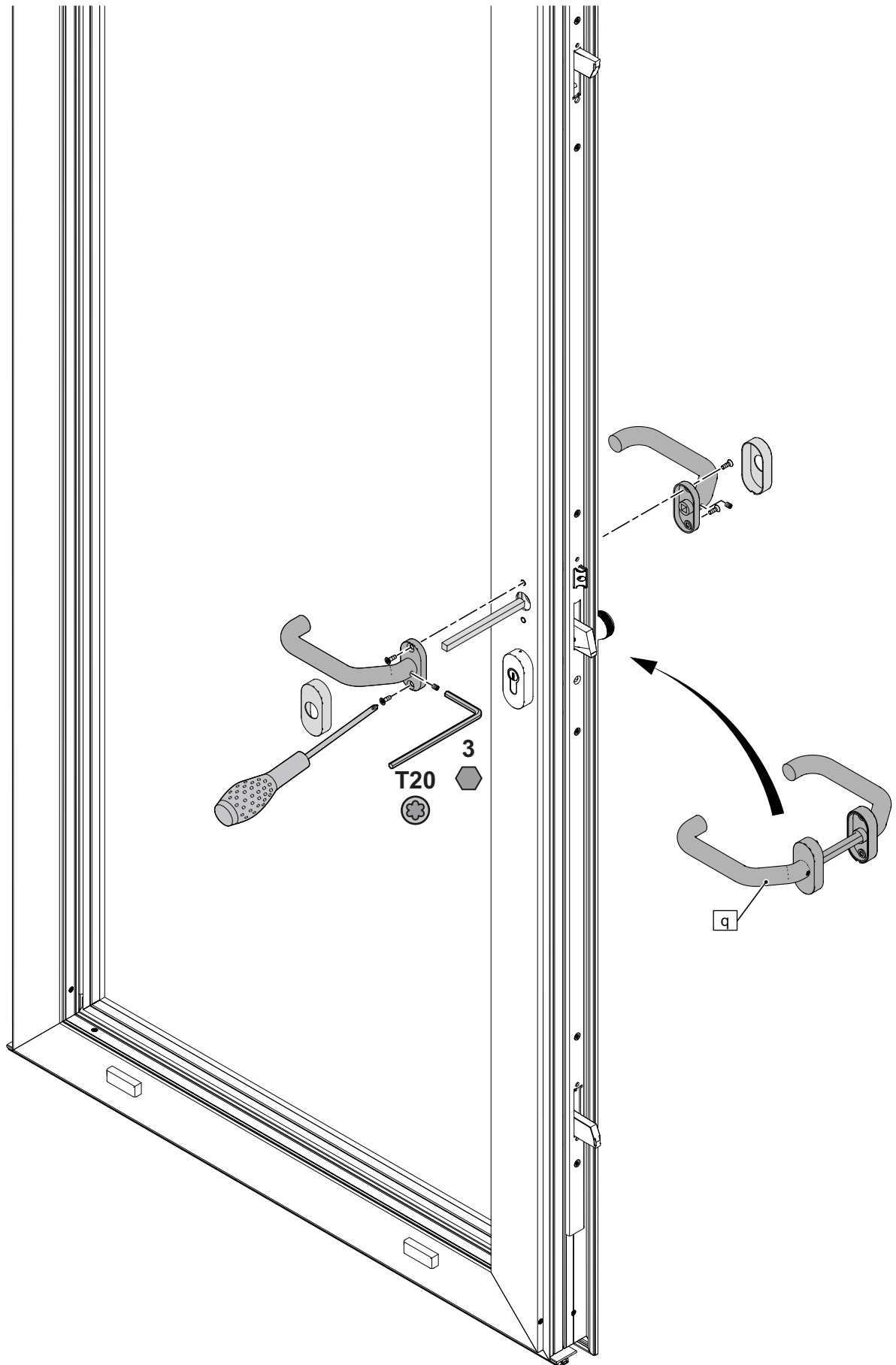

14

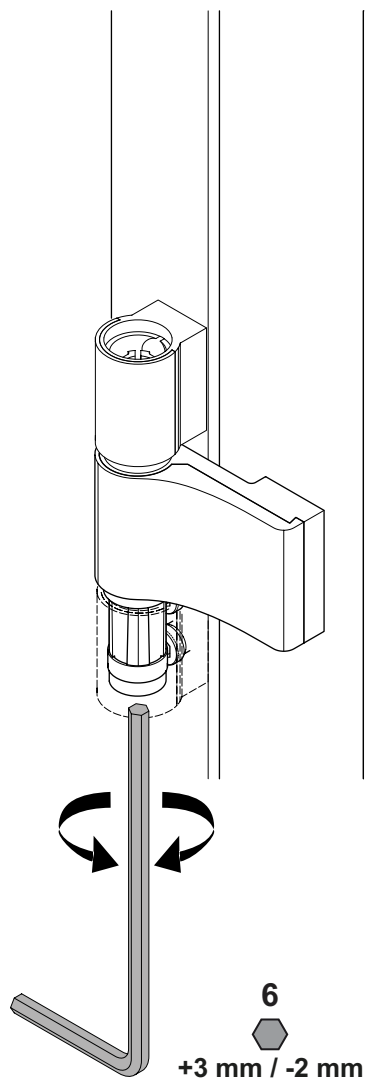
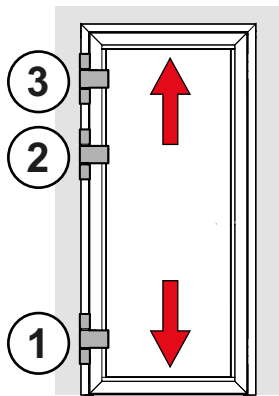

# 15

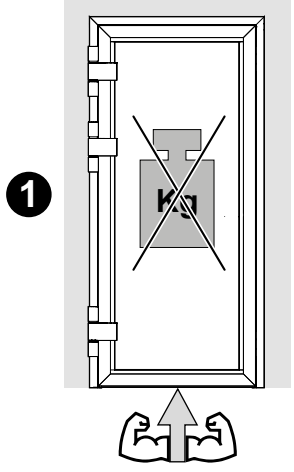
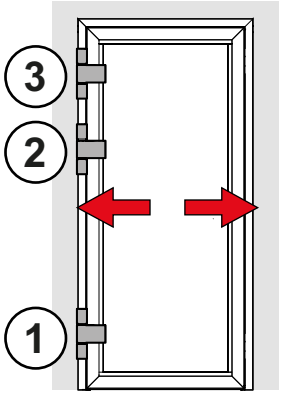

3  
+2 mm / -2 mm

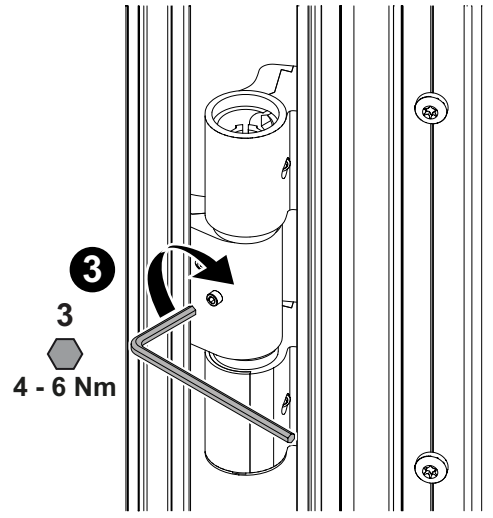
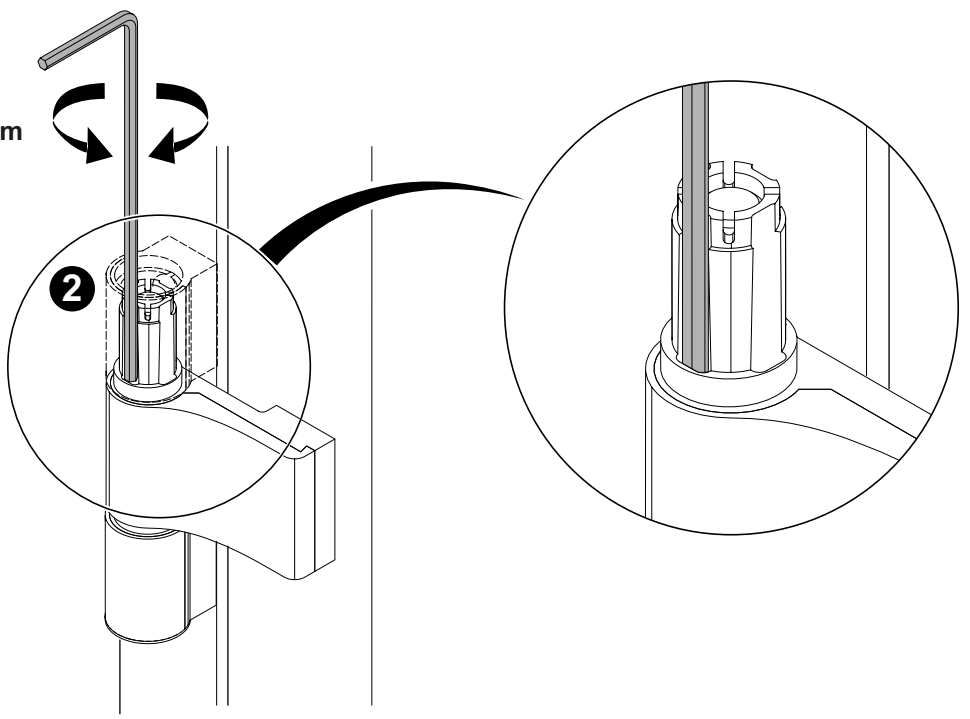



16

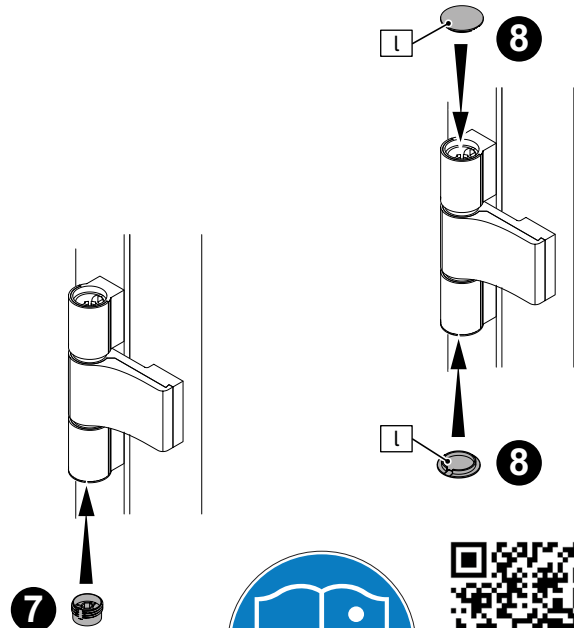
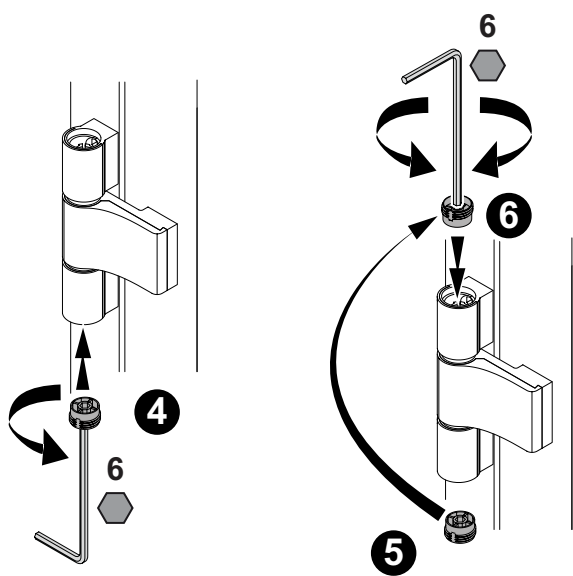
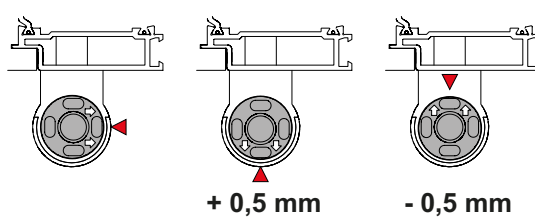
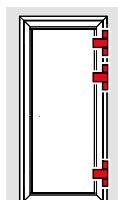
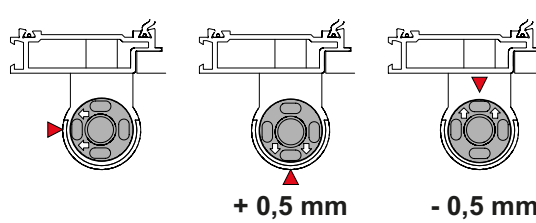
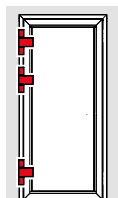
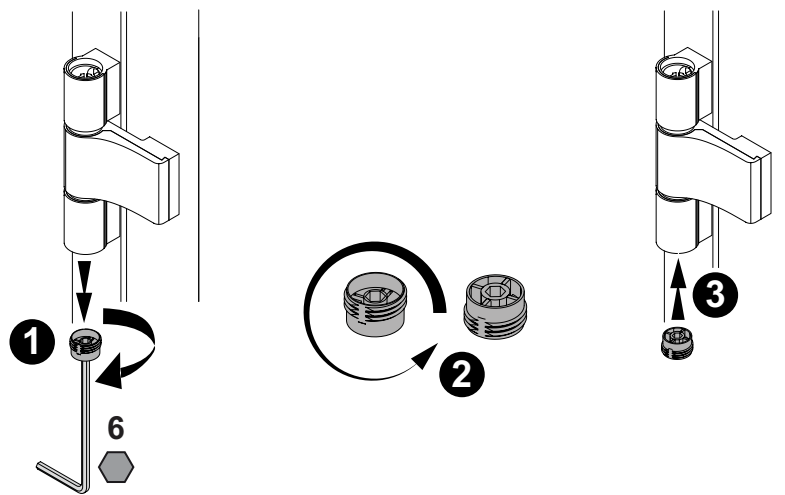
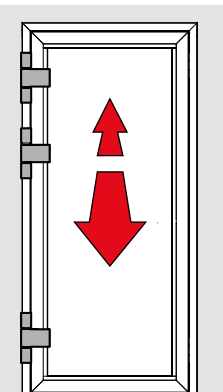

17

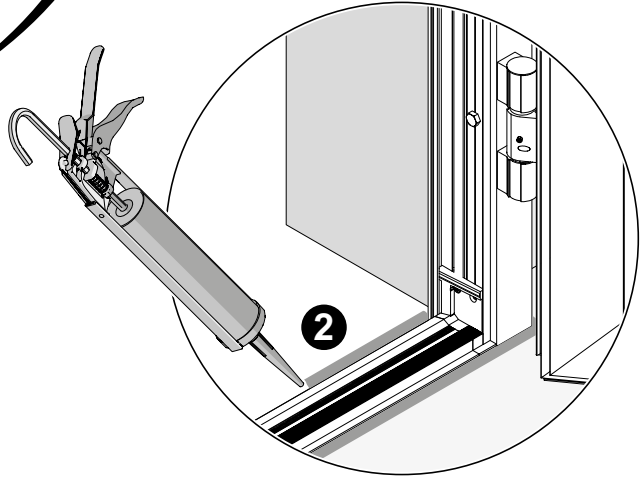
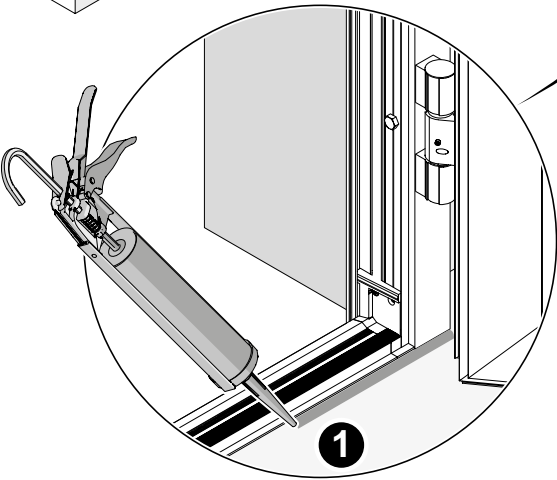
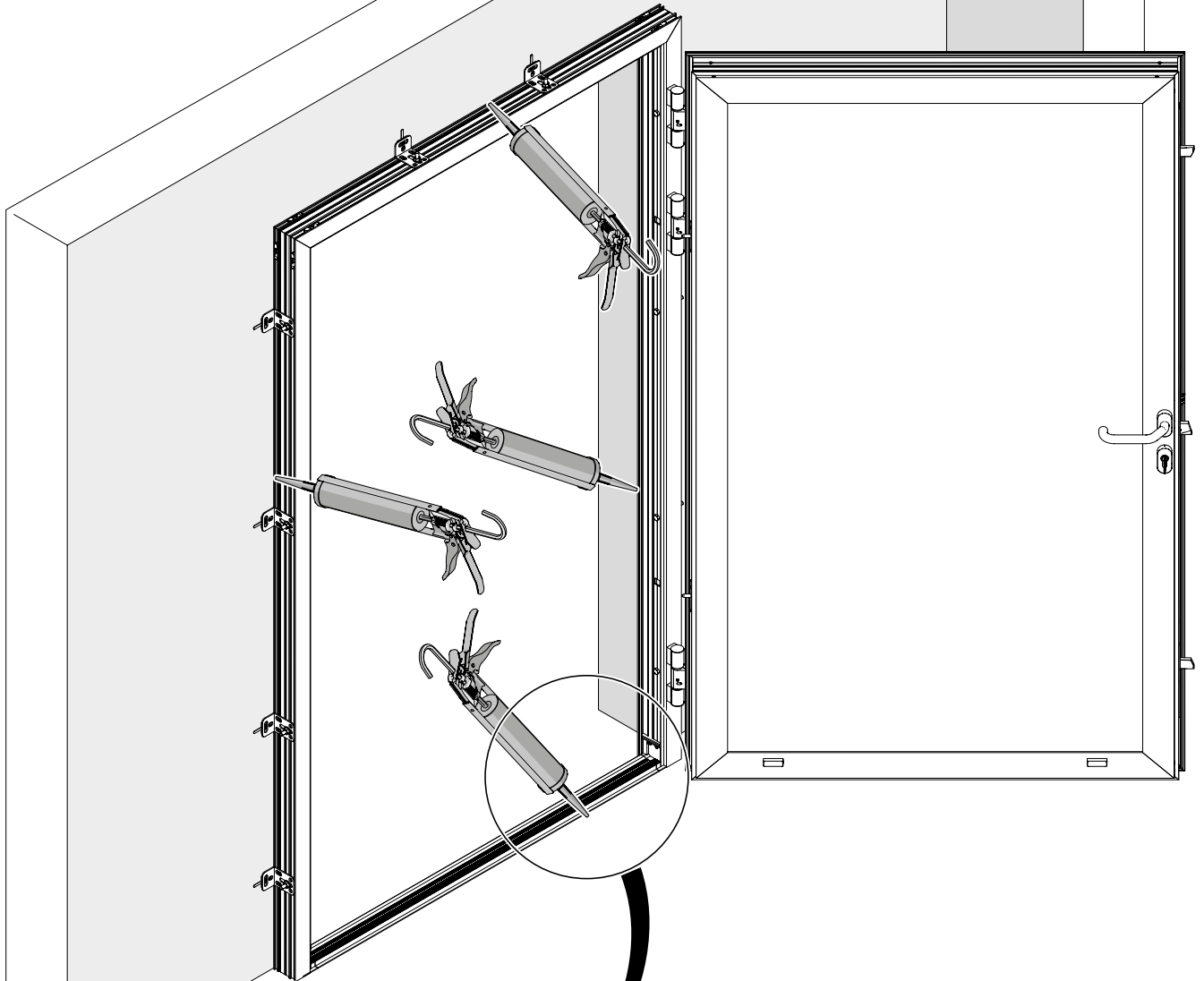

**18**

Extérieure  
Nach Außen  
To the outside

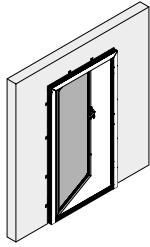

E

Si ferme porte  
If door closer  
Bei Türschliesser

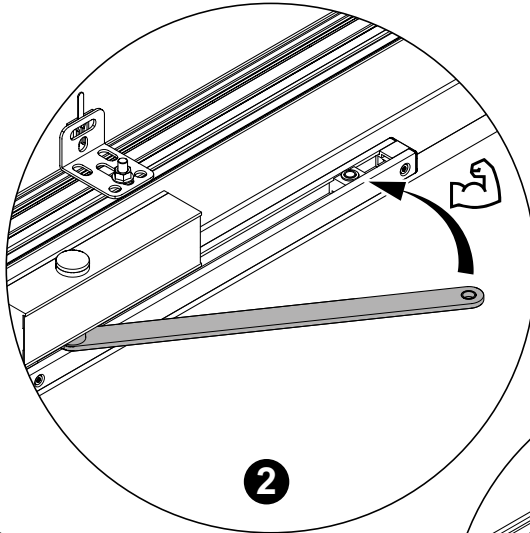

**2**

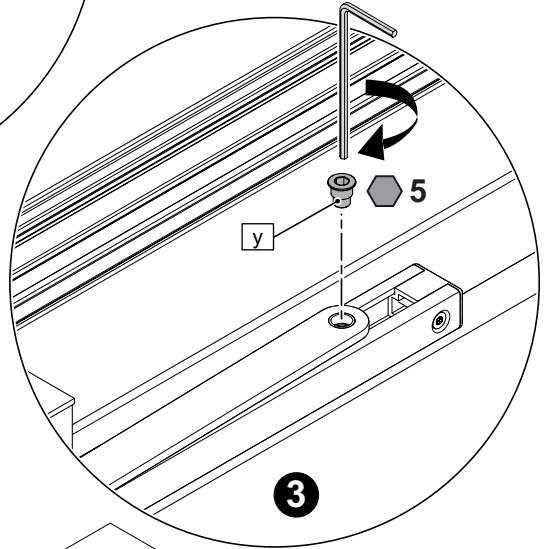

**3**

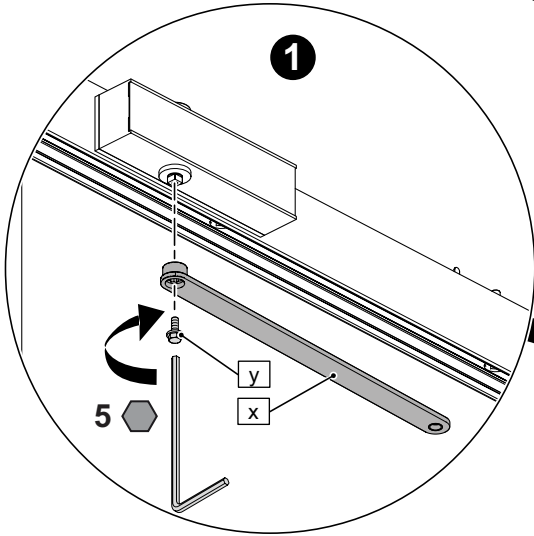

**1**

5

y

x

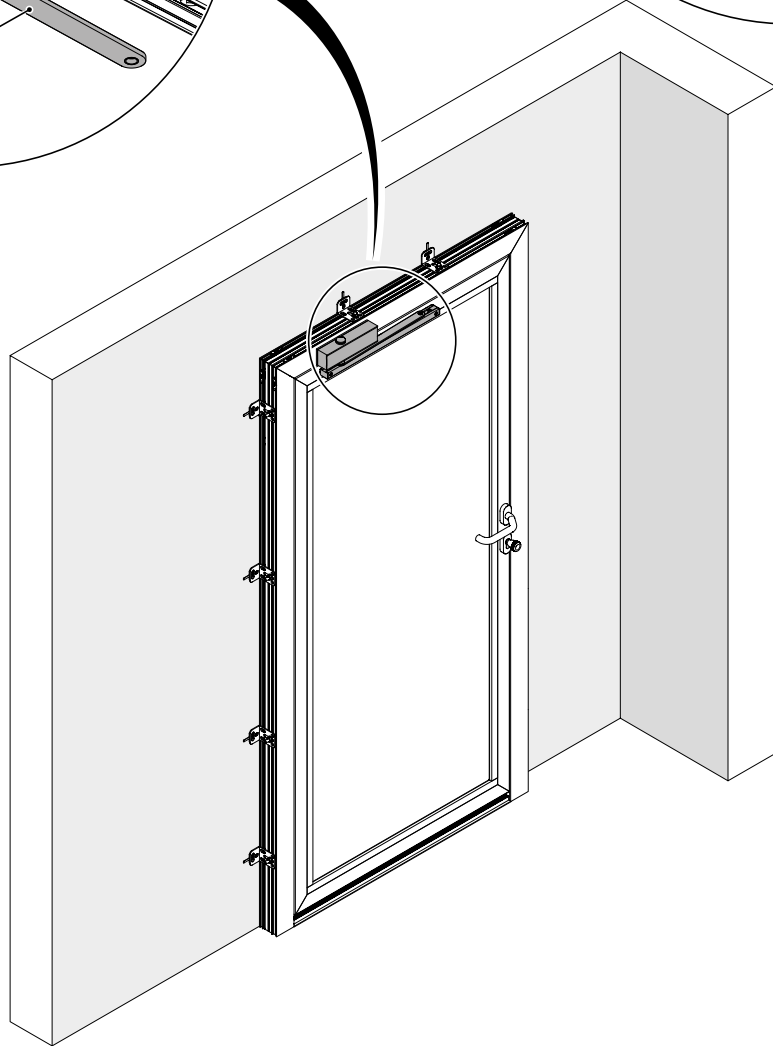

**19**

Intérieure  
Nach Innen  
To the inside

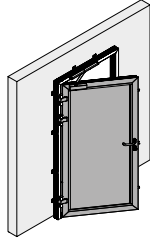

**I**

Si ferme porte  
If door closer  
Bei Türschliesser

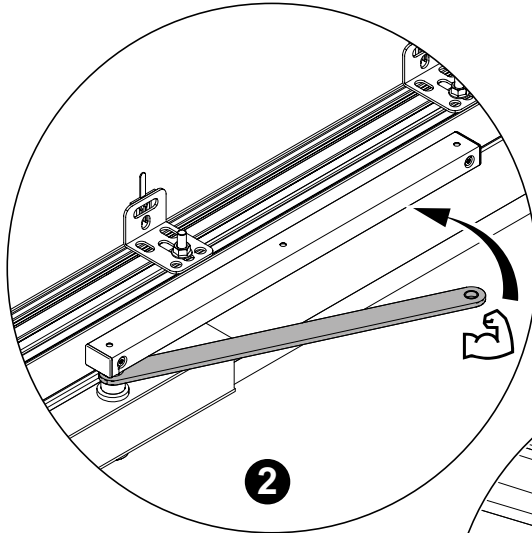

**2**

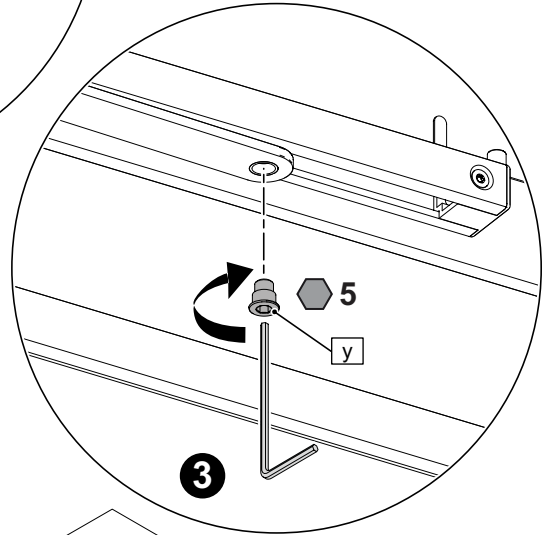

**3**

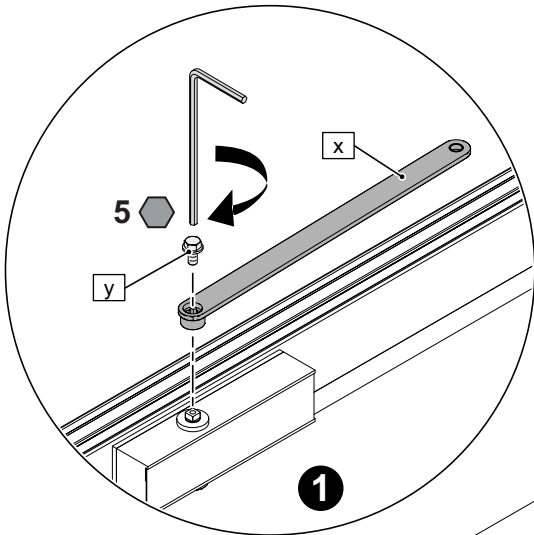

**1**

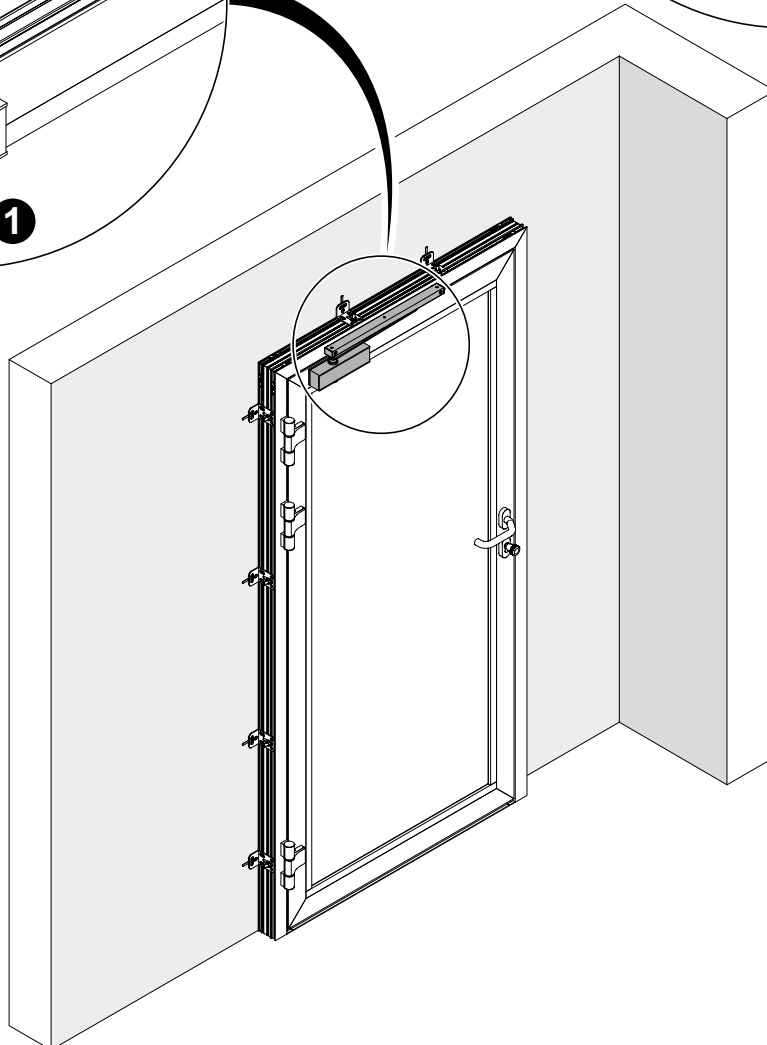

20

Si vérin  
lf gas spring  
Bei Gasfeder

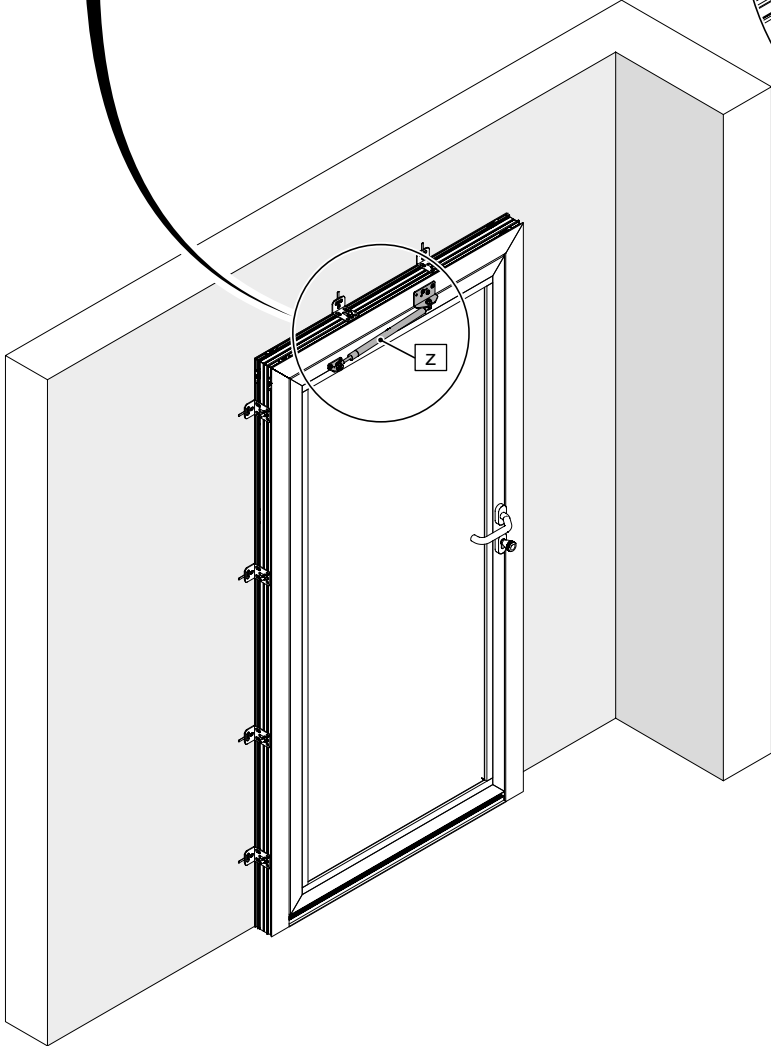
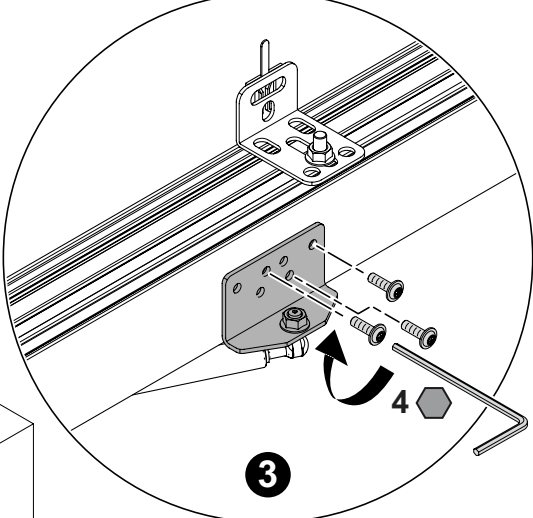
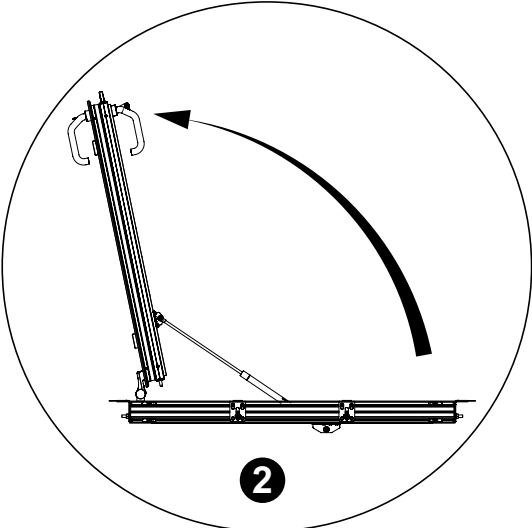
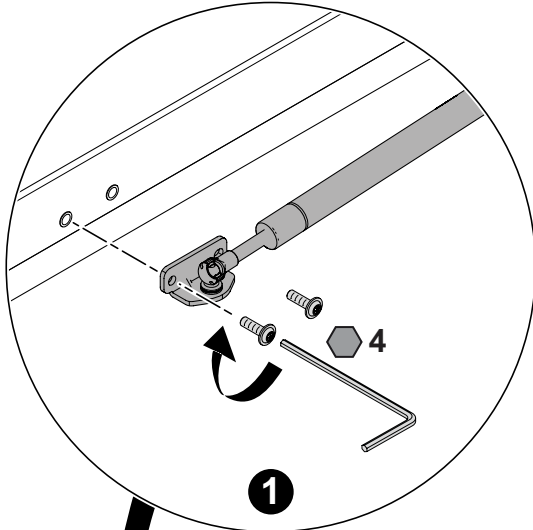

90°	>90°







*L'autre entrée principale*



Adresses sur [quefairedemesdechets.fr](http://quefairedemesdechets.fr)