

T 400 DS

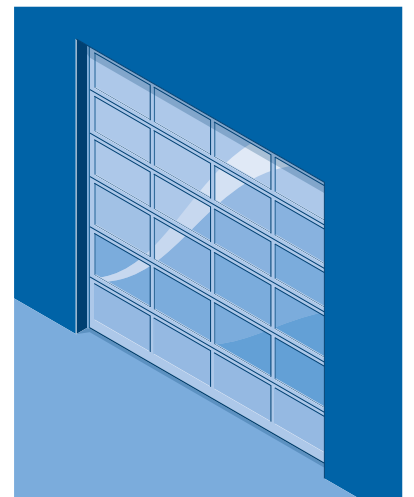

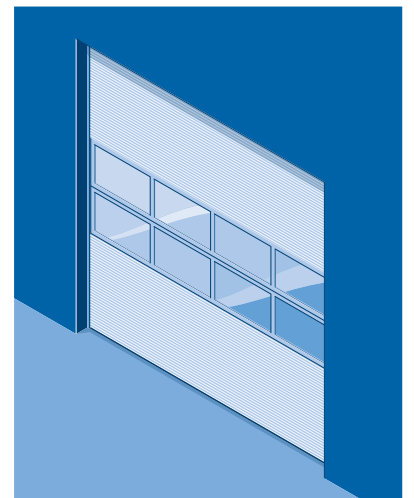

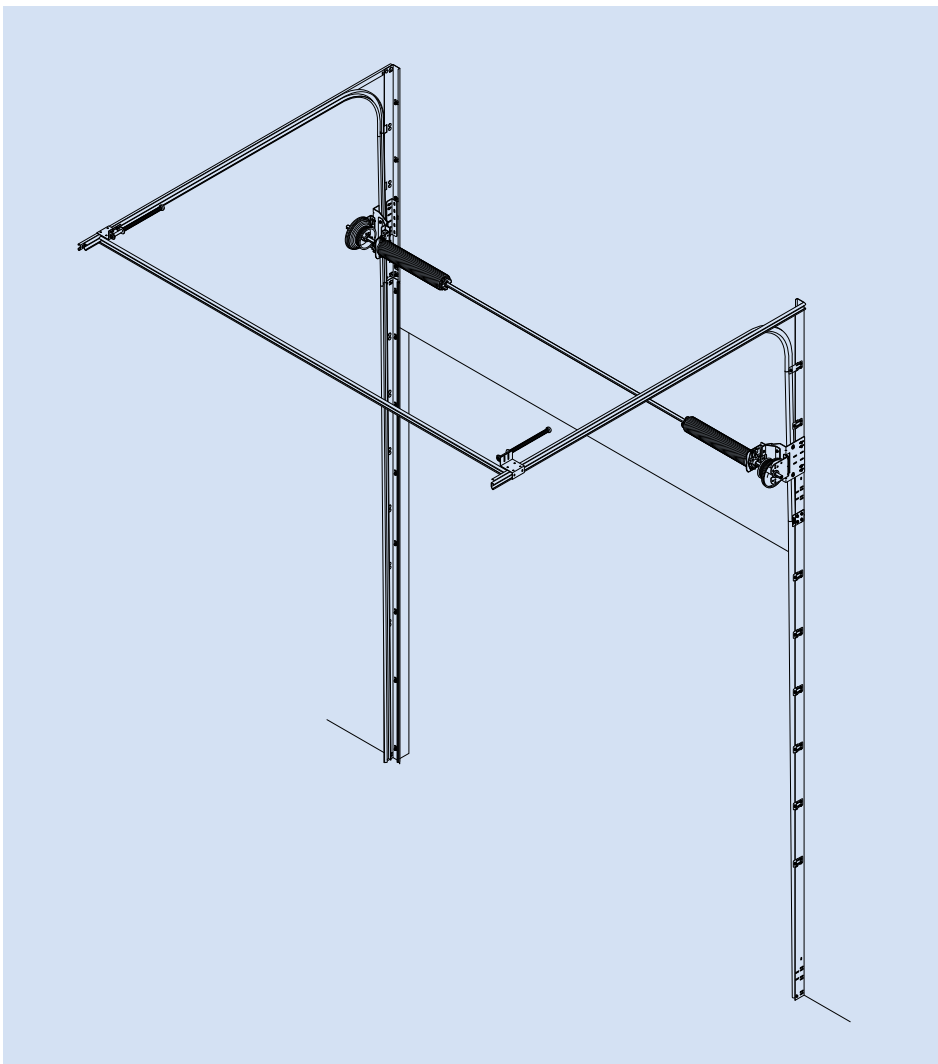
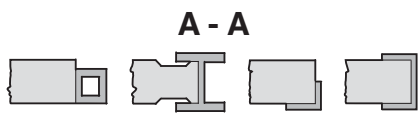
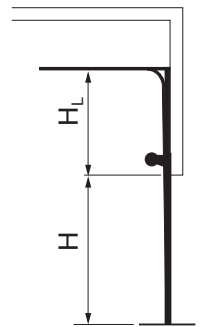
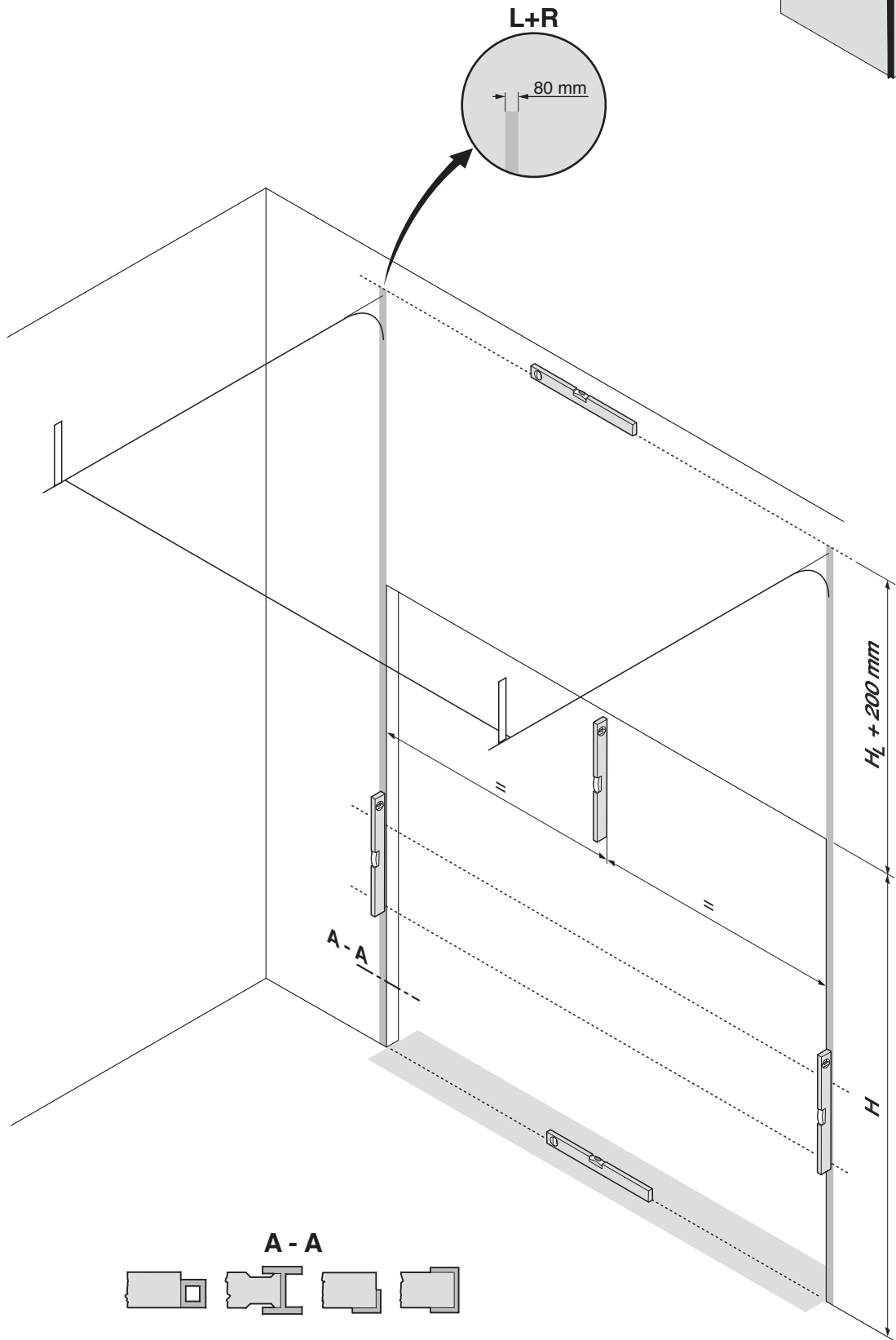
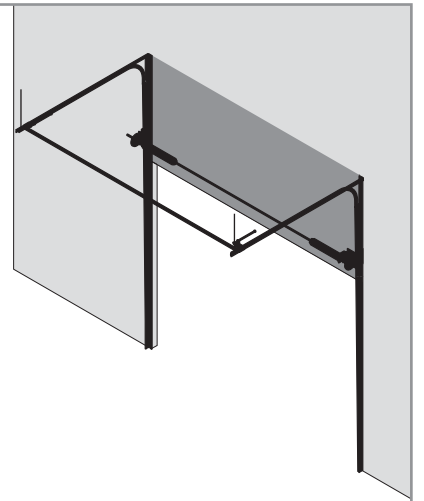
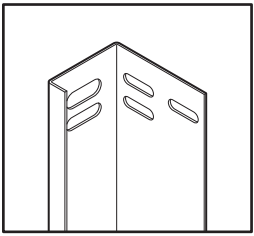
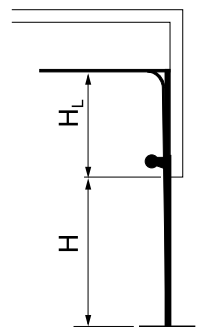
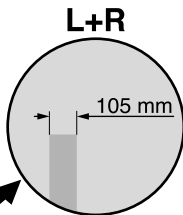
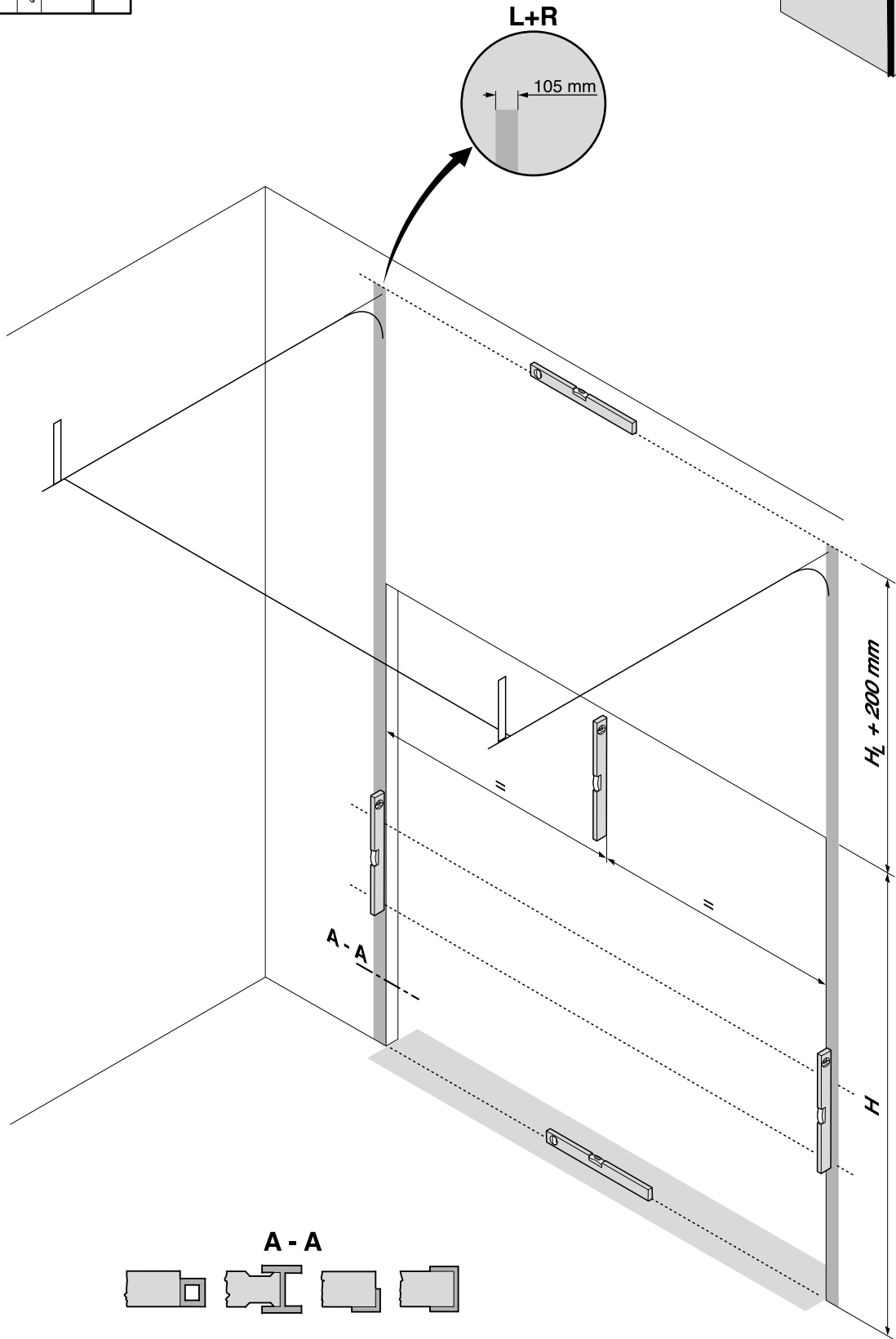
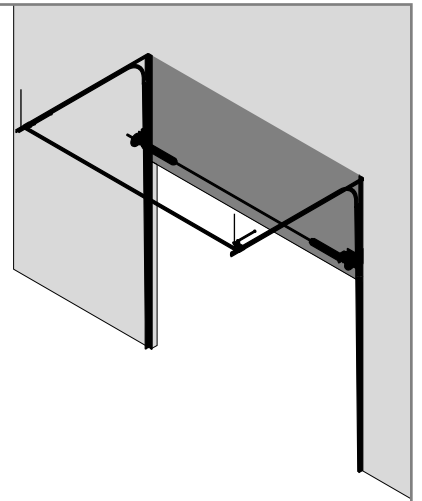
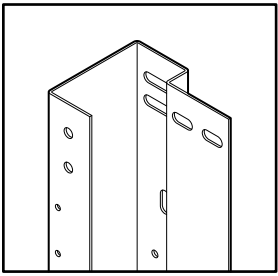

A - A

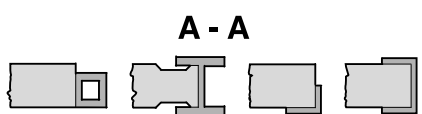

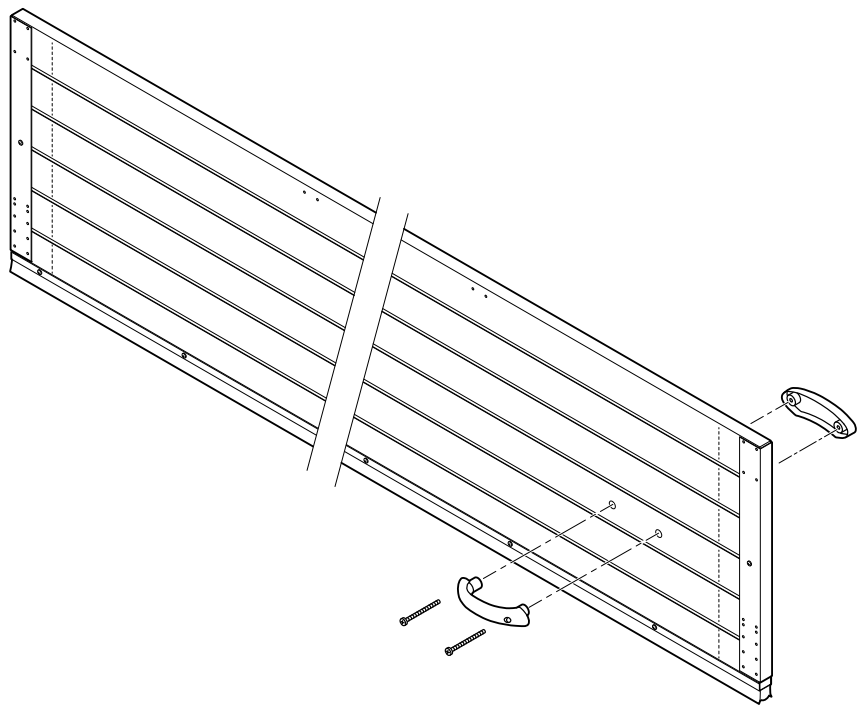
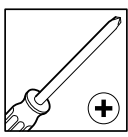
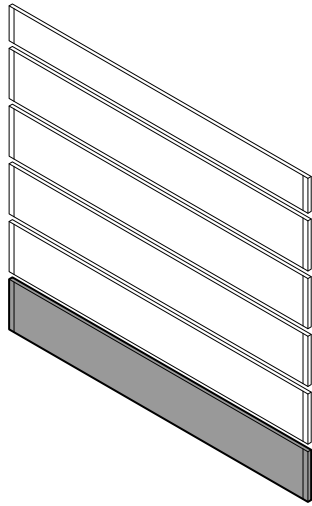

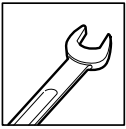

2x
⚠ 6,3x35mm
3Nm

2x
⚠ 6,3x13mm
3Nm

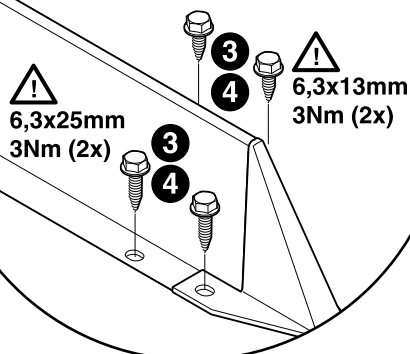
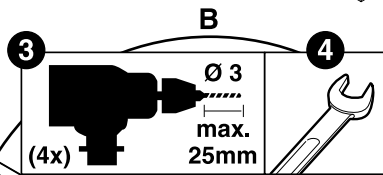
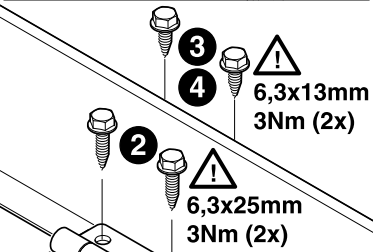
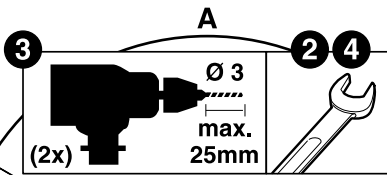
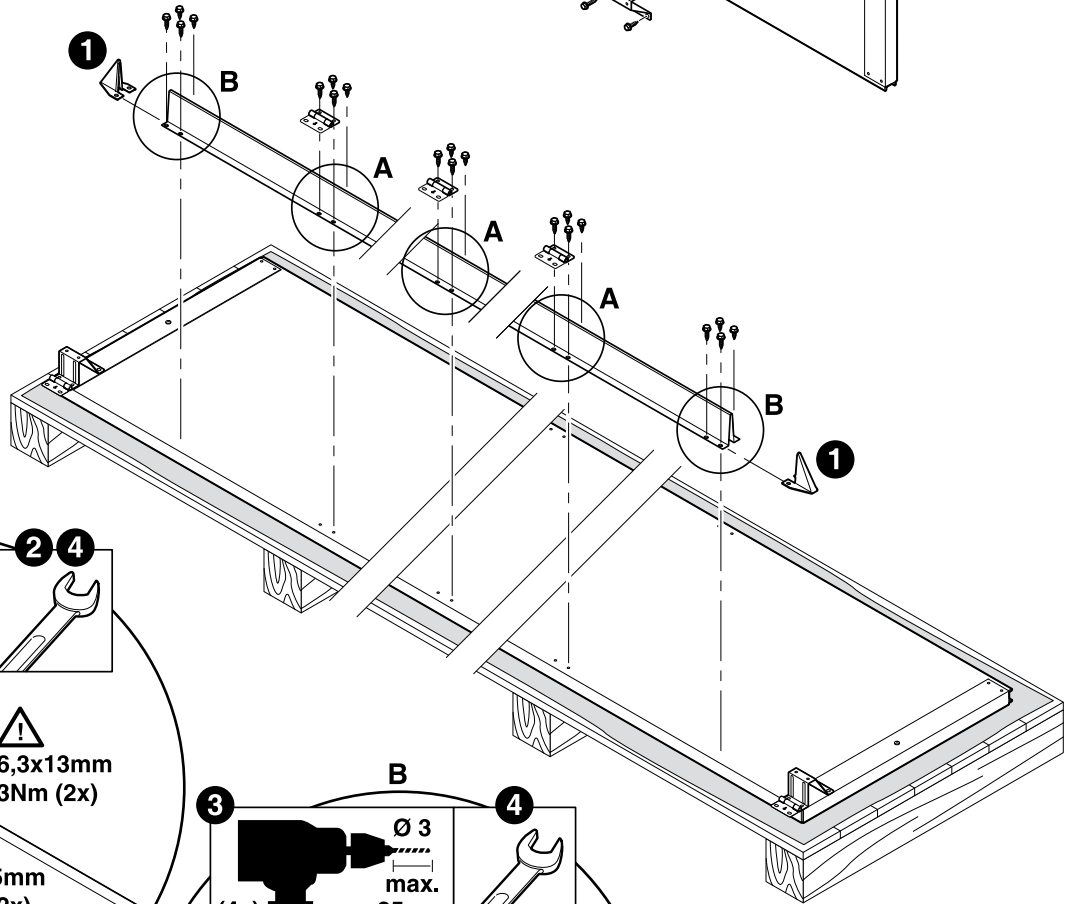
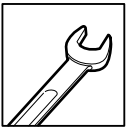
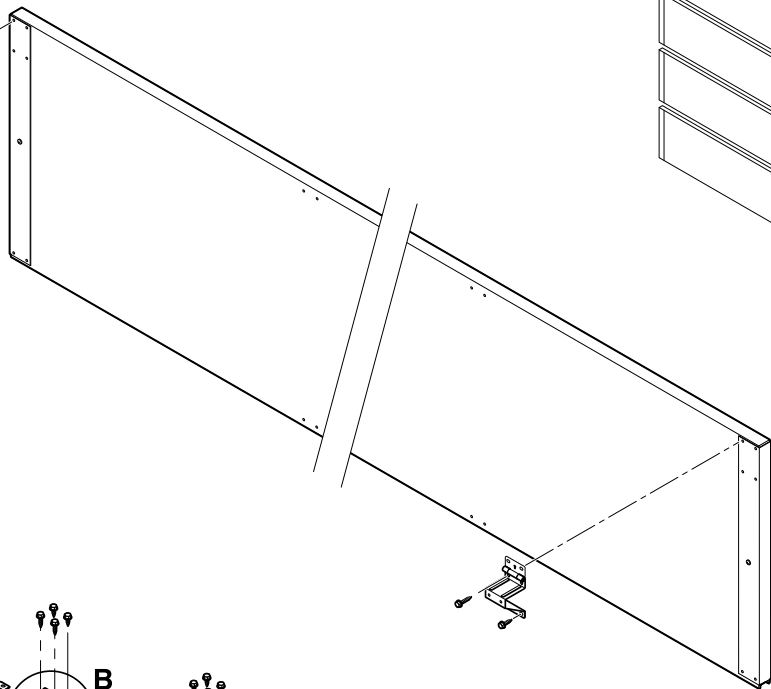
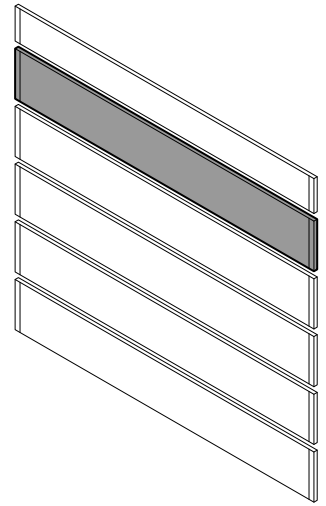

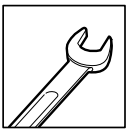
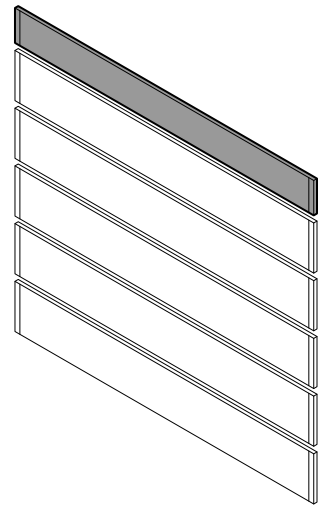

2x
⚠ 6,3x35mm
3Nm

2x
⚠ 6,3x13mm
3Nm

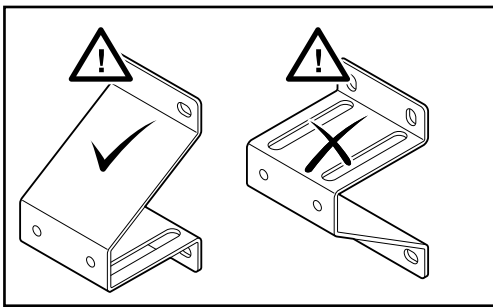
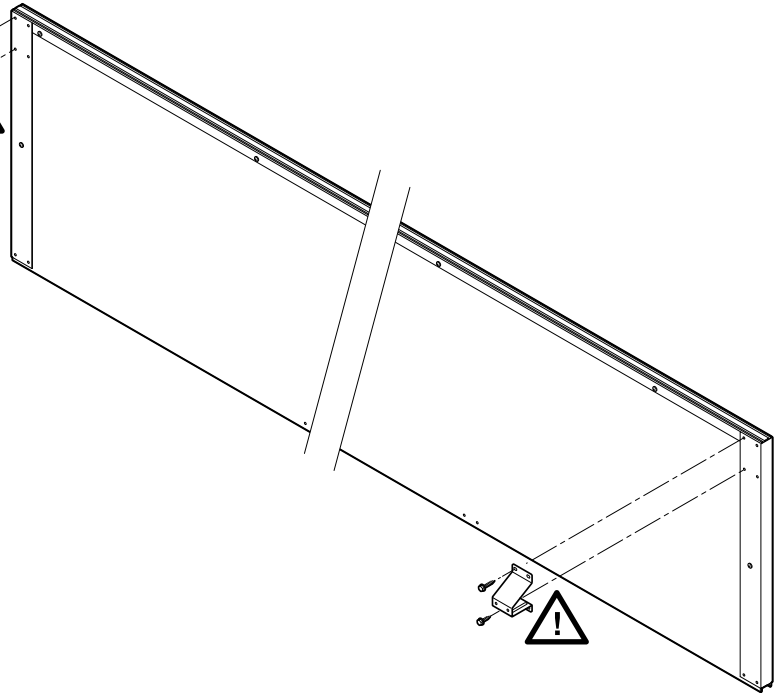

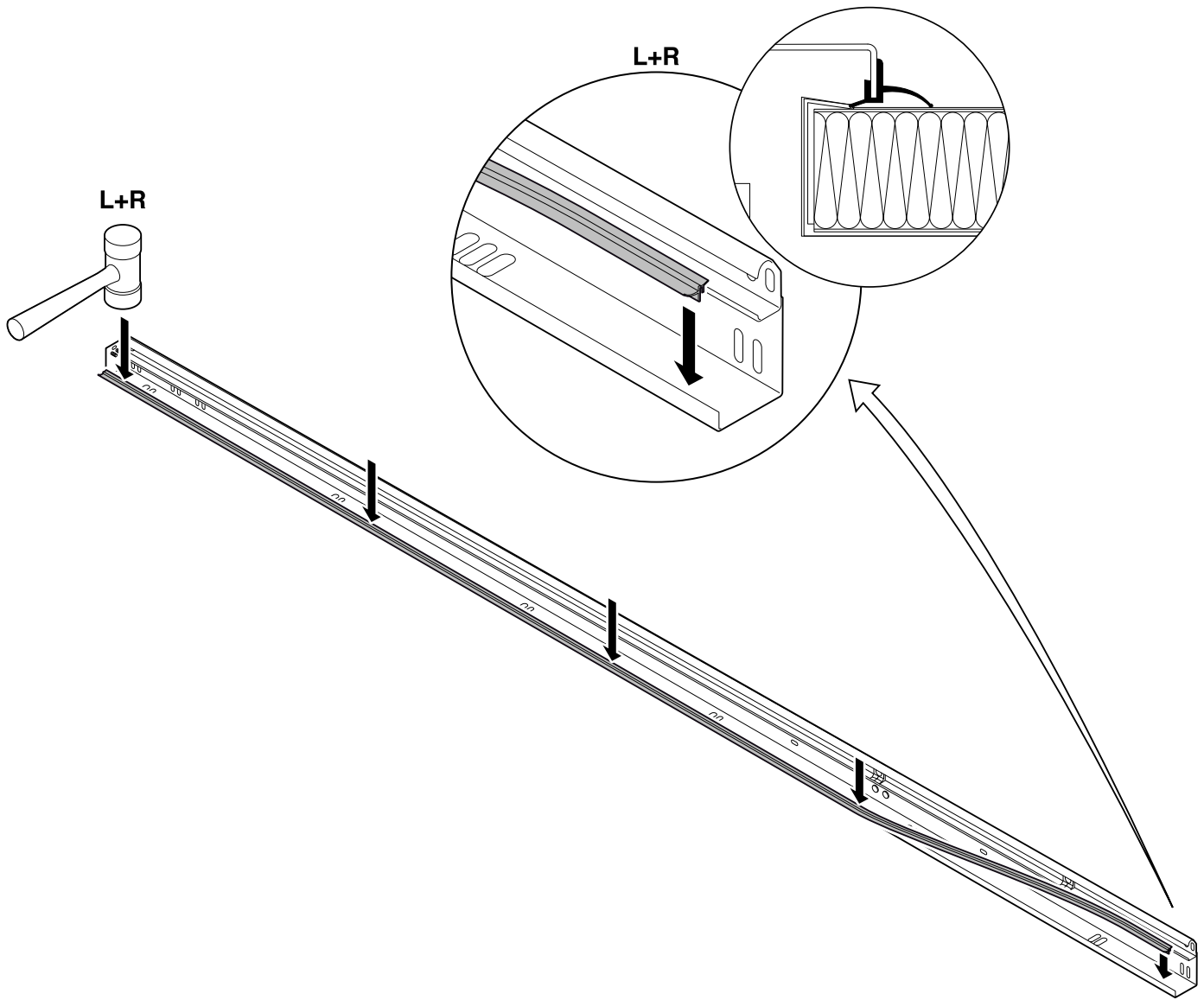

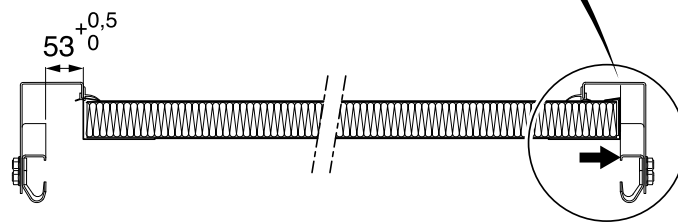
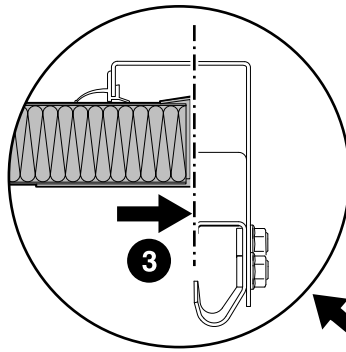
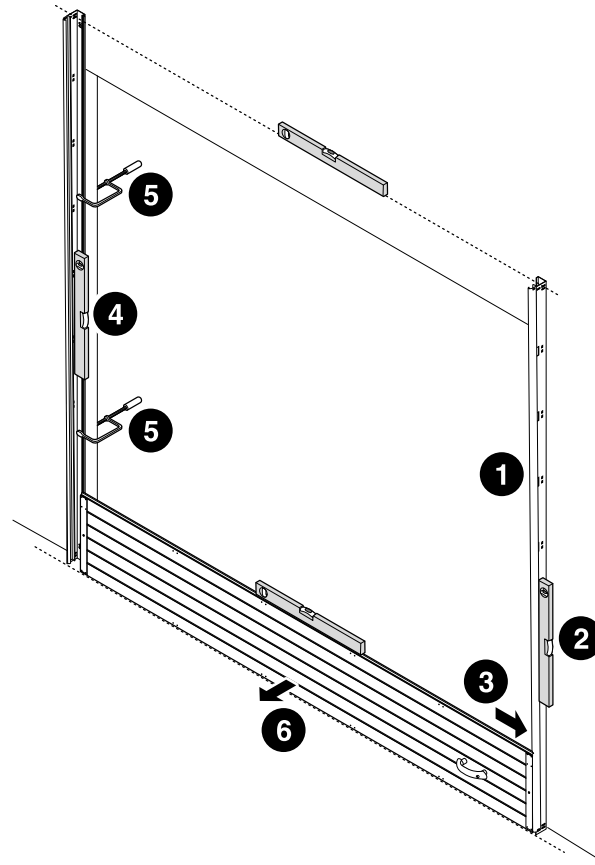
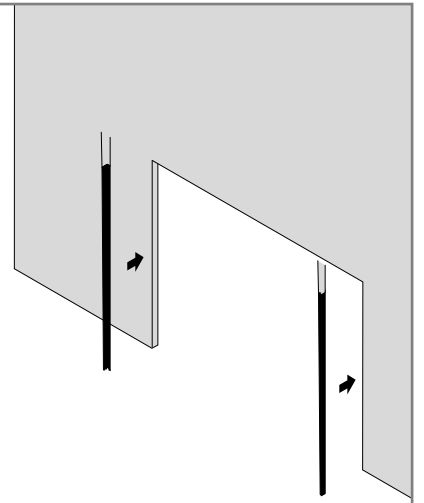
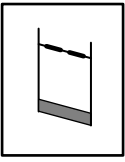

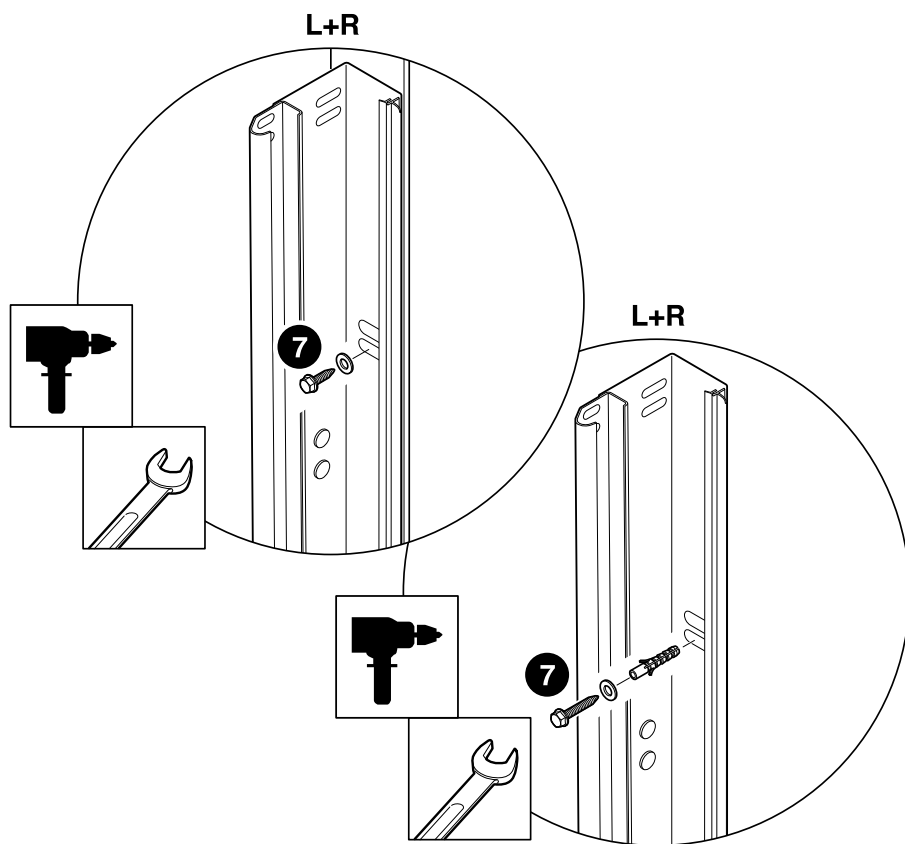
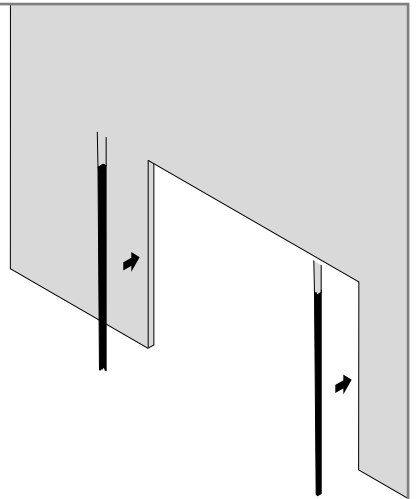
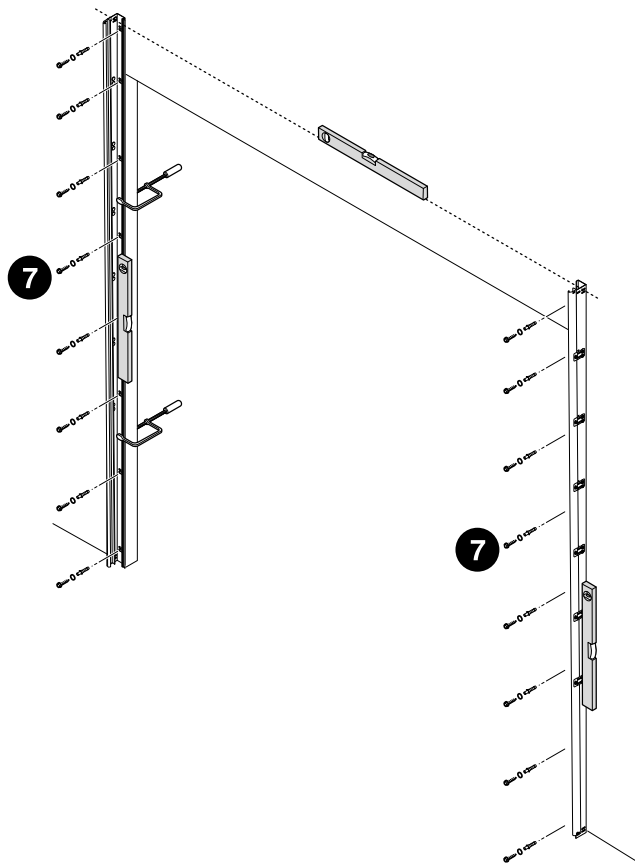
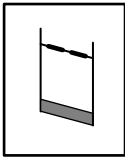

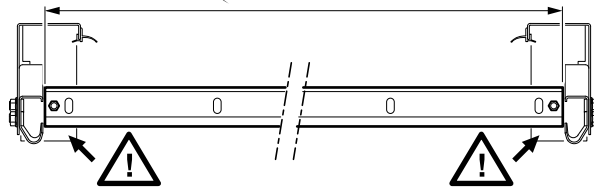
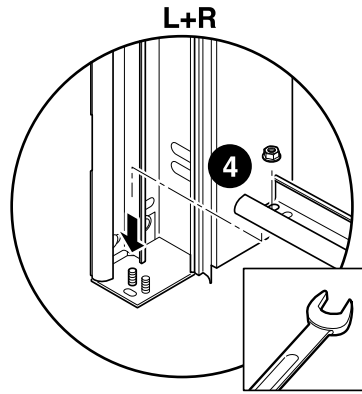
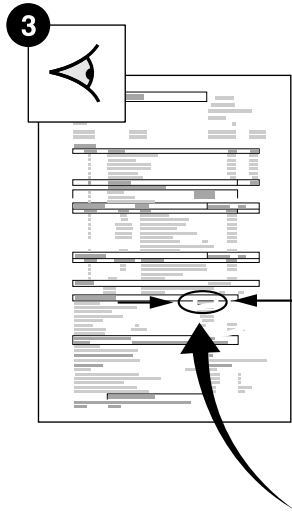
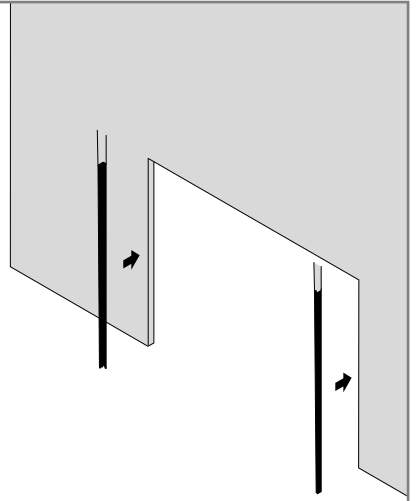
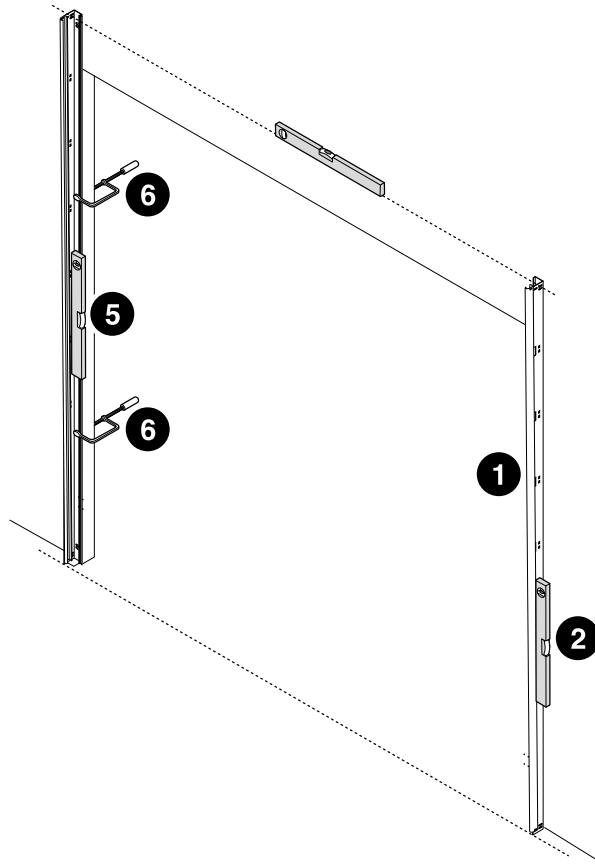

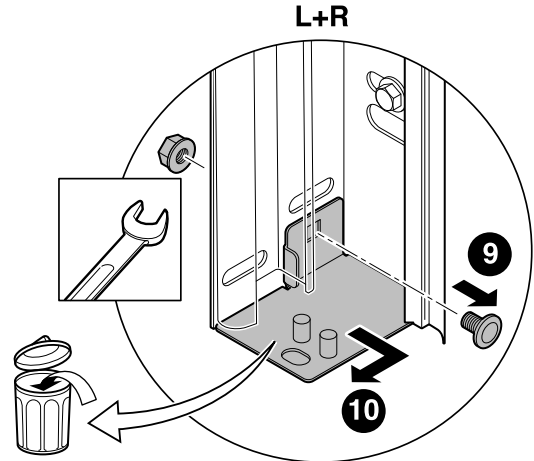
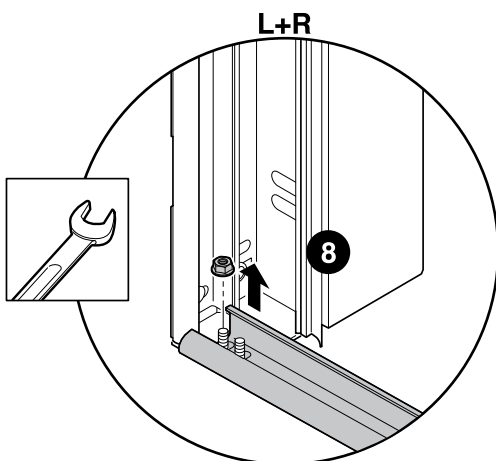
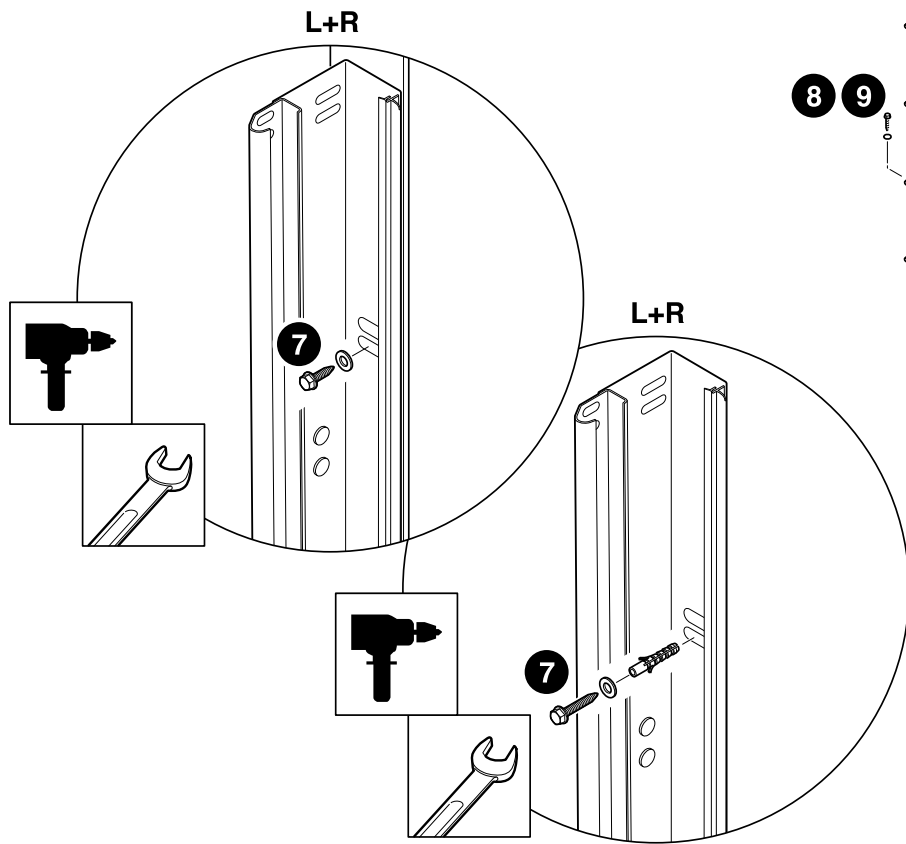
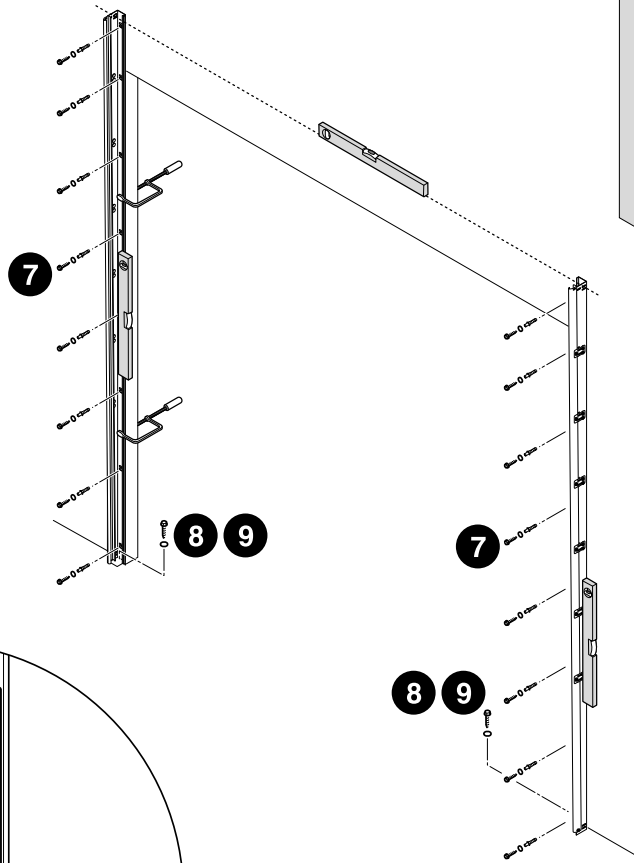

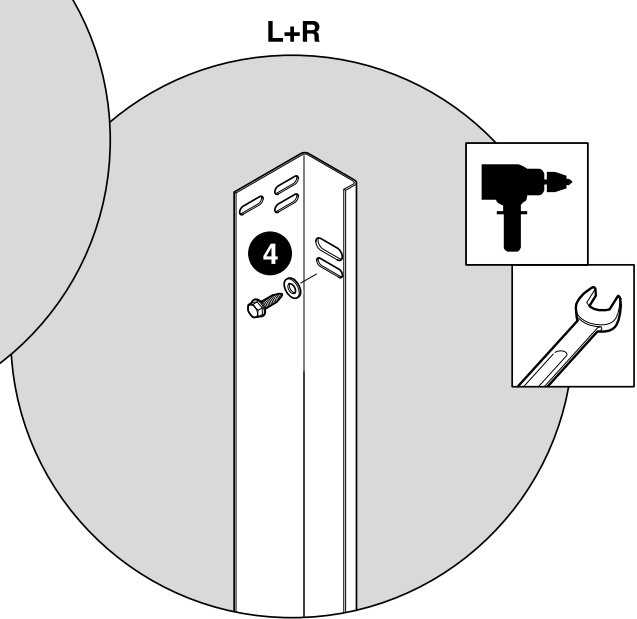
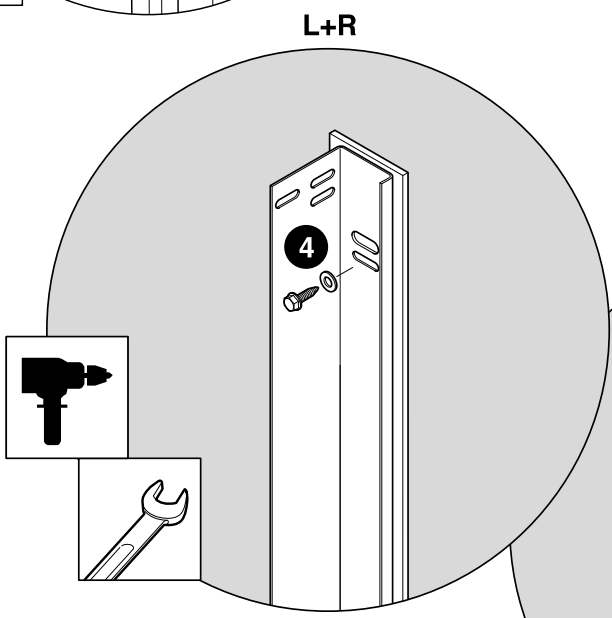
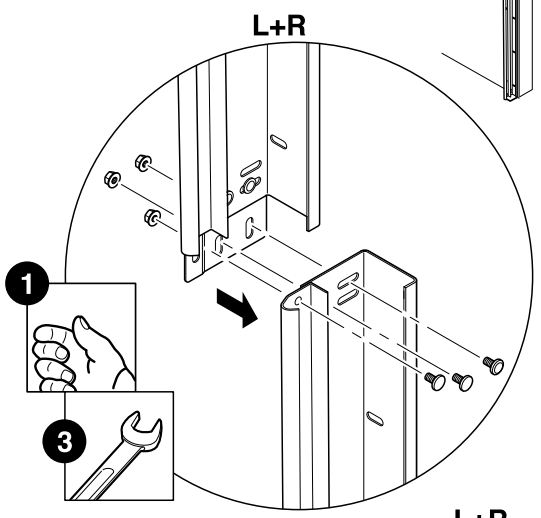
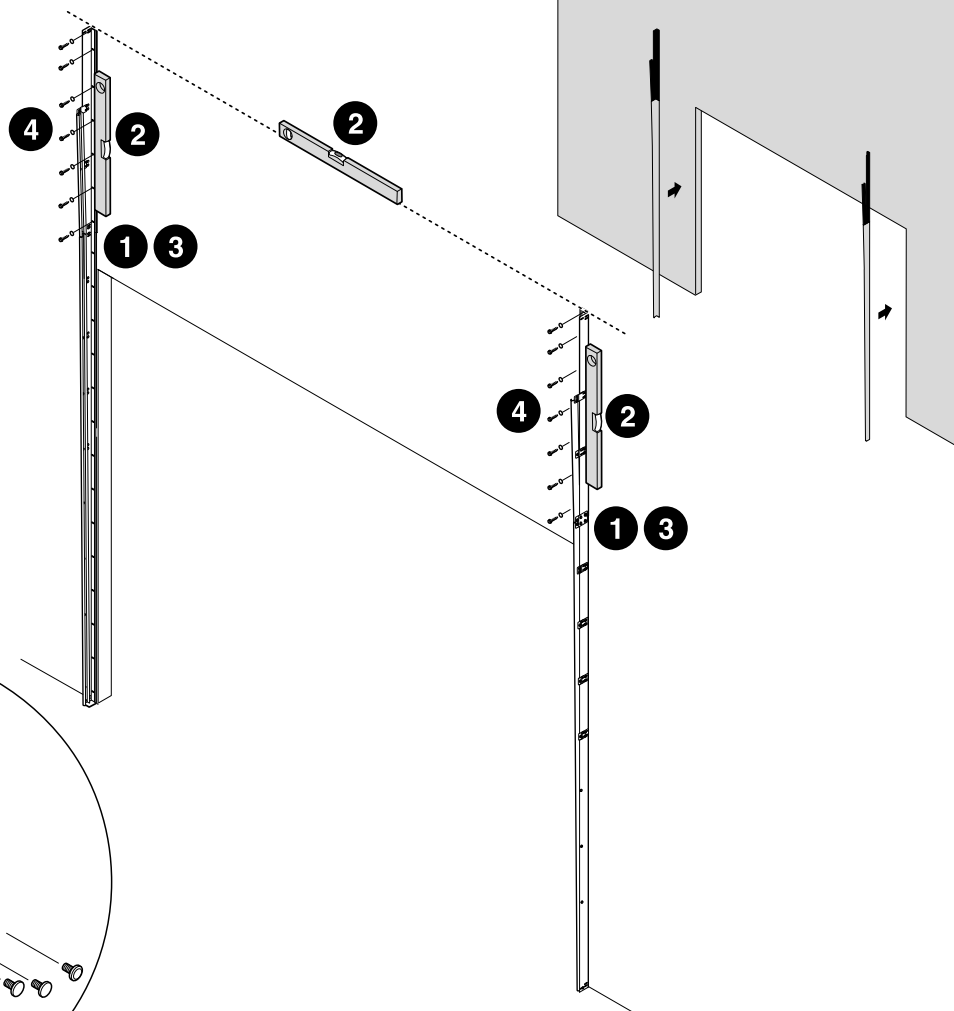

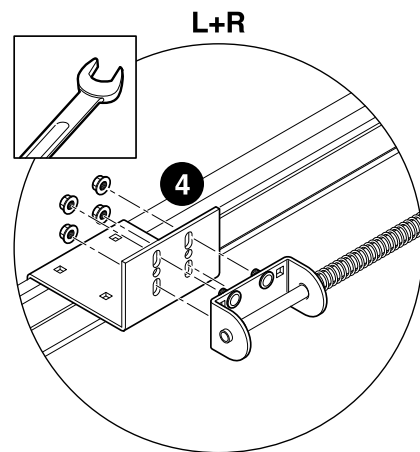
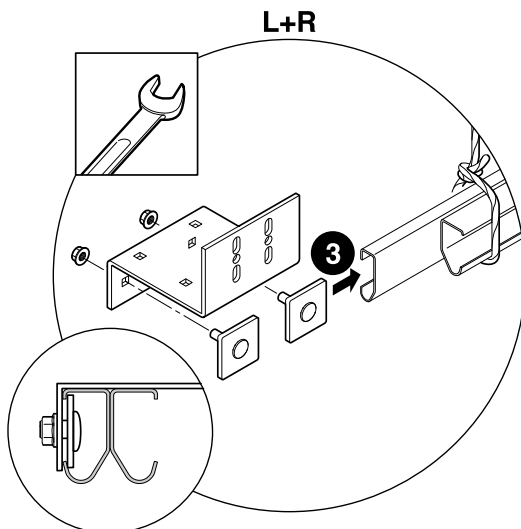
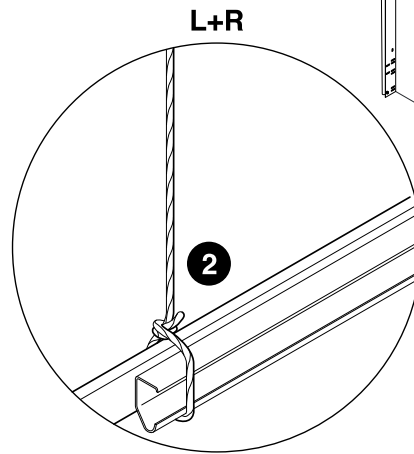
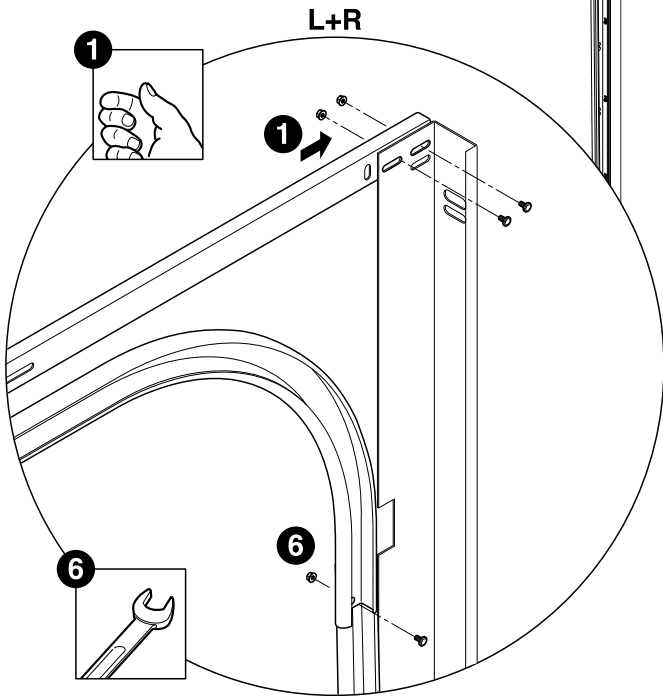
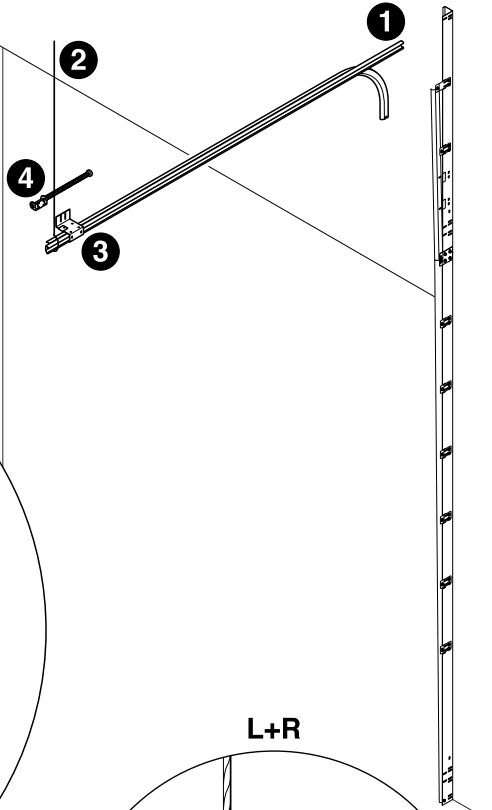
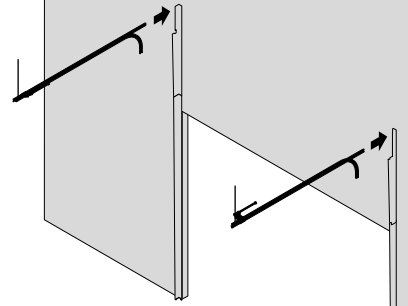
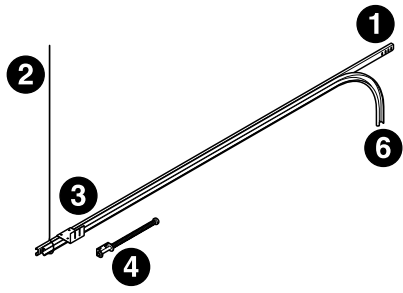
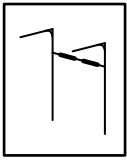

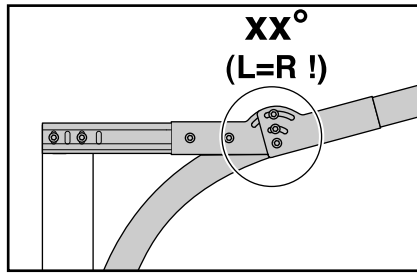
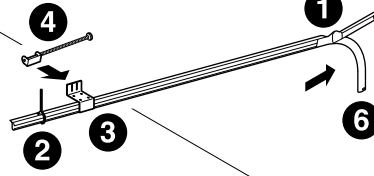
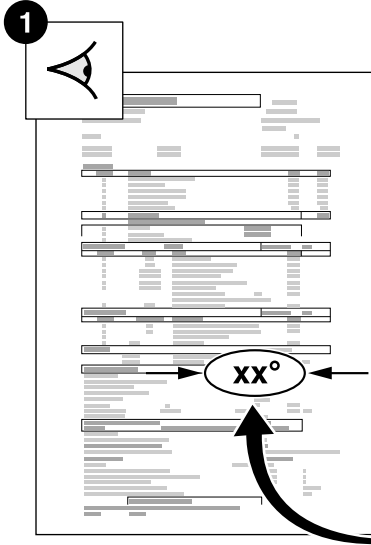
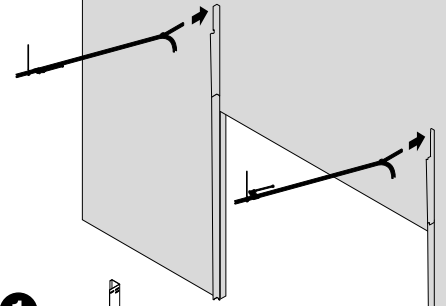
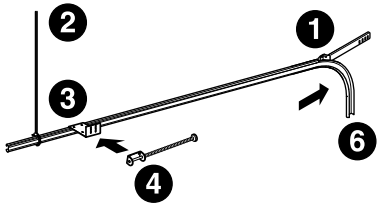
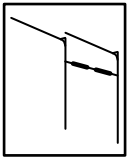

L+R

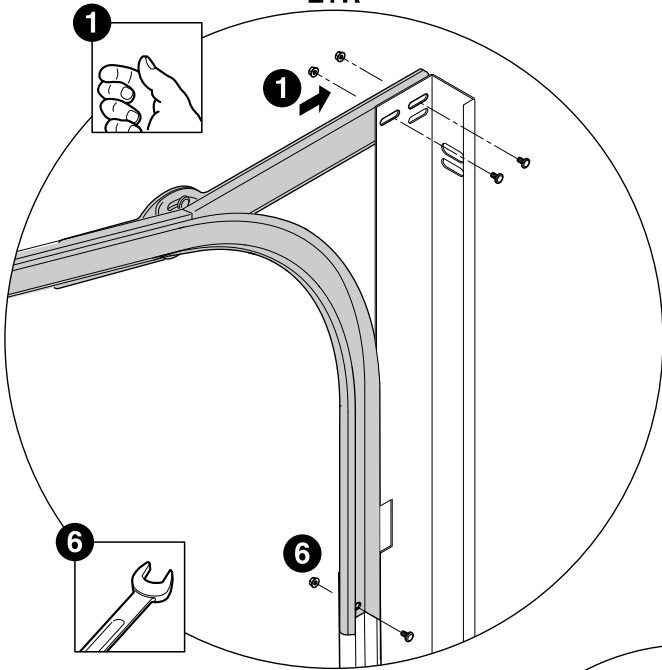

L+R

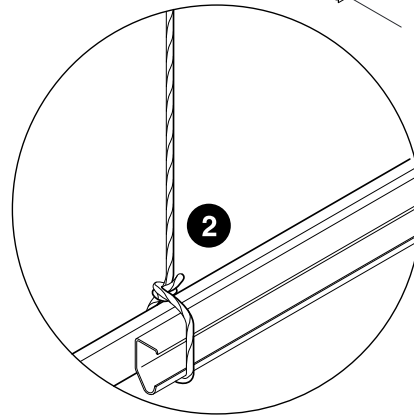

L+R

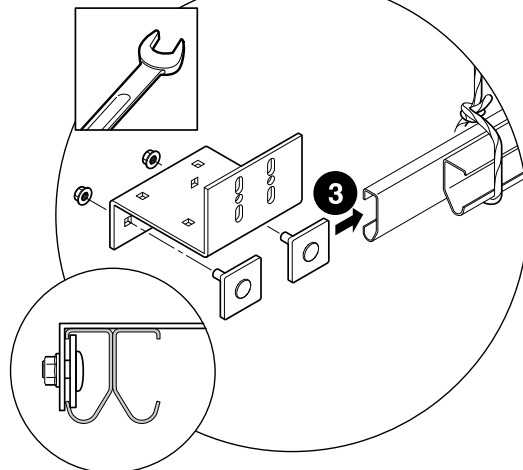

L+R

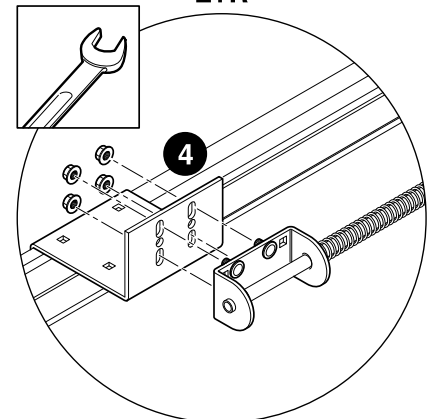

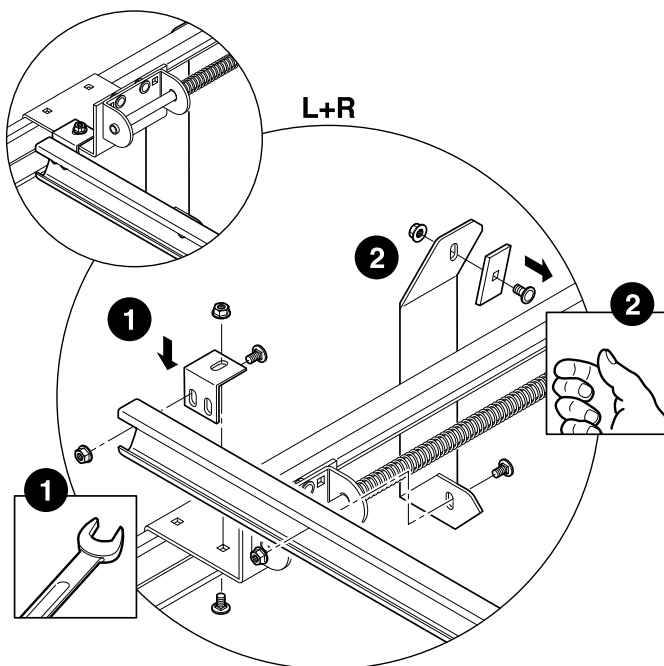
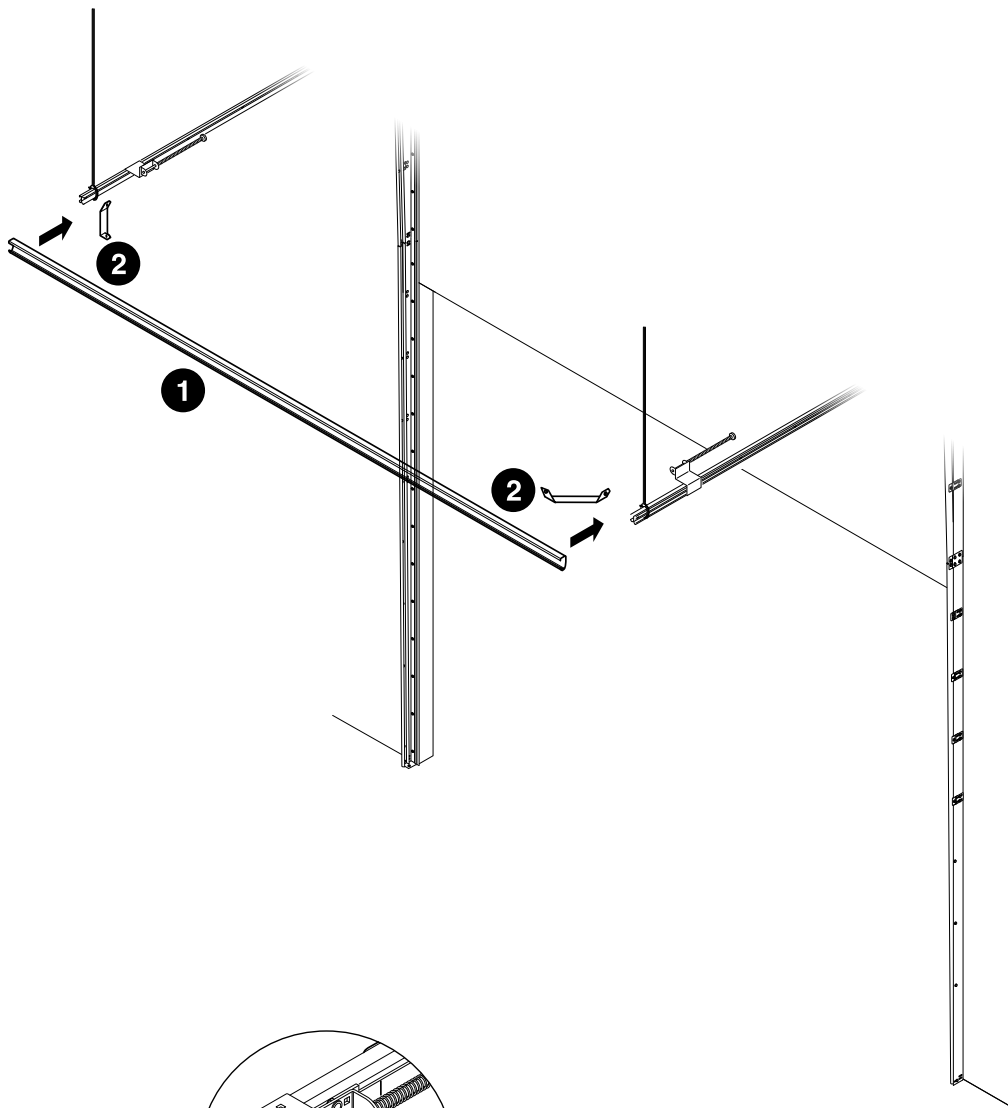
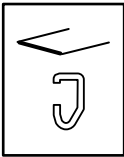

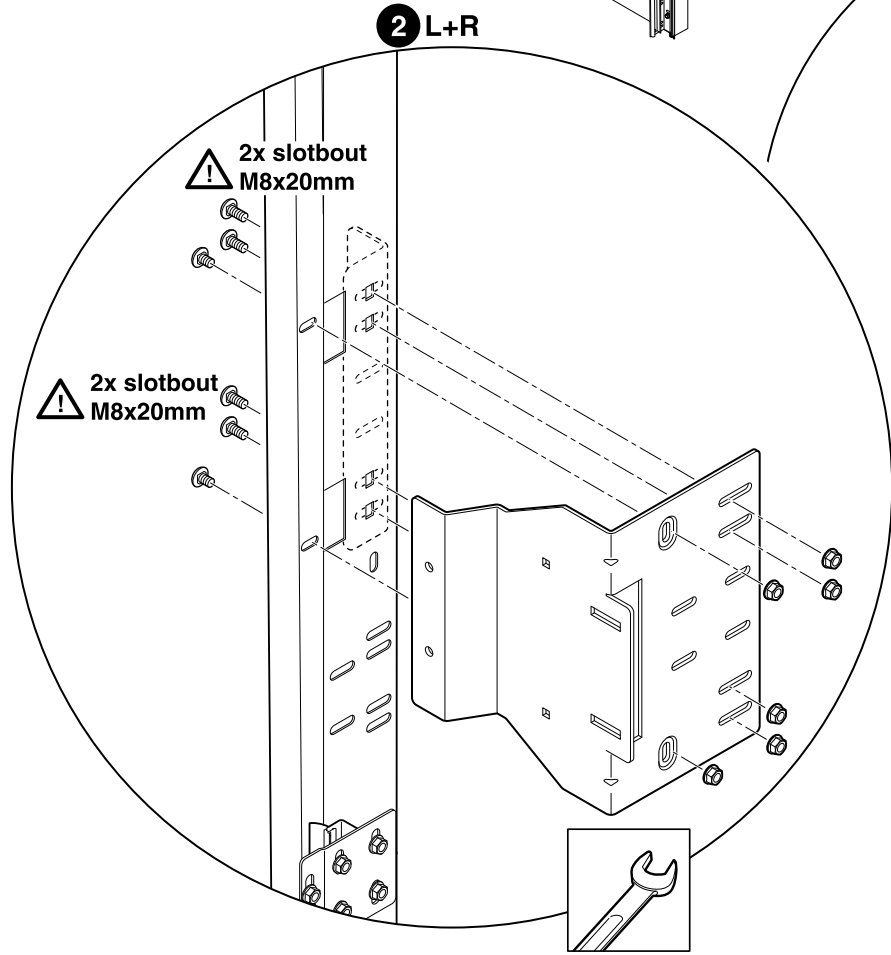
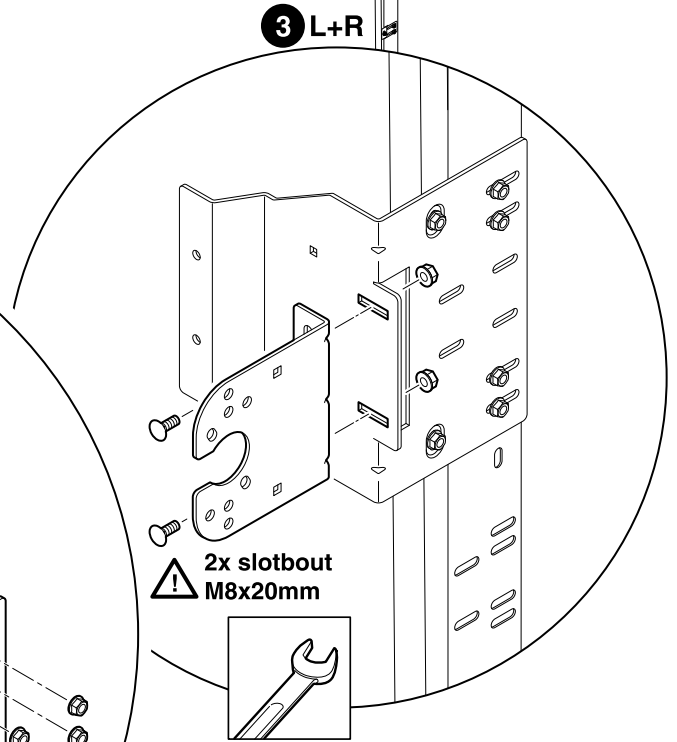
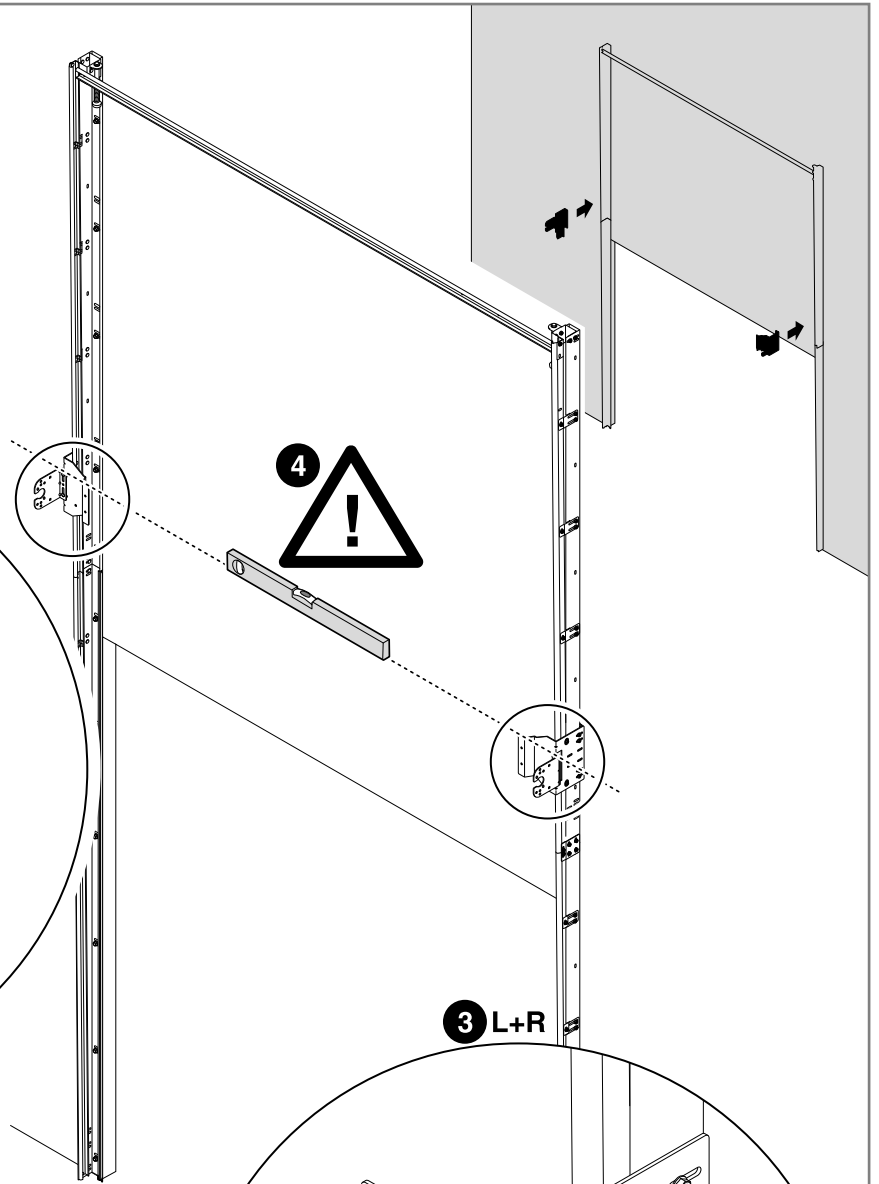
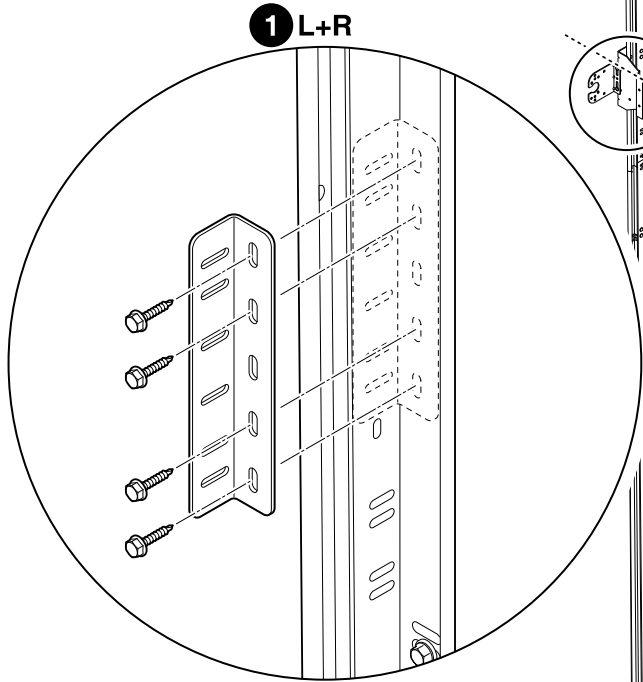
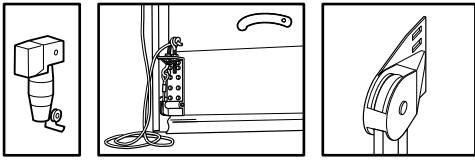

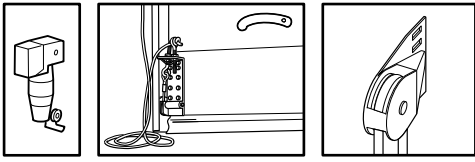

5 L+R

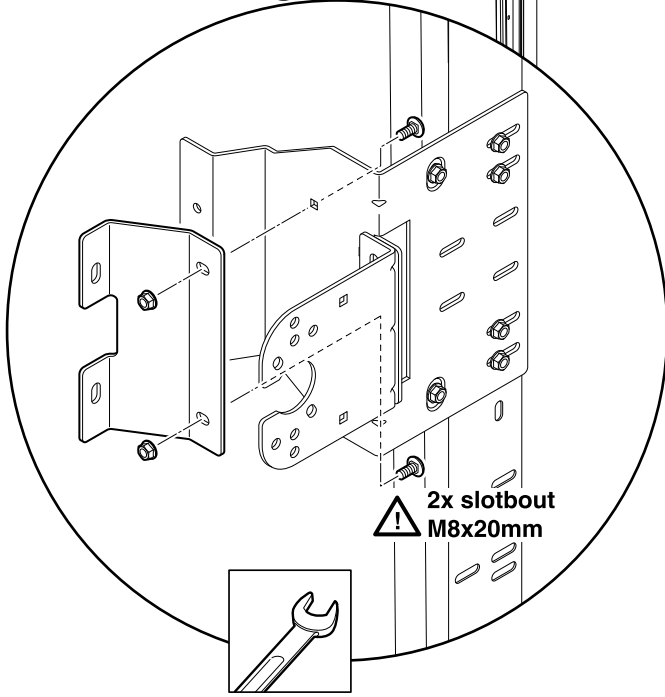

⚠ 2x slotbout M8x20mm

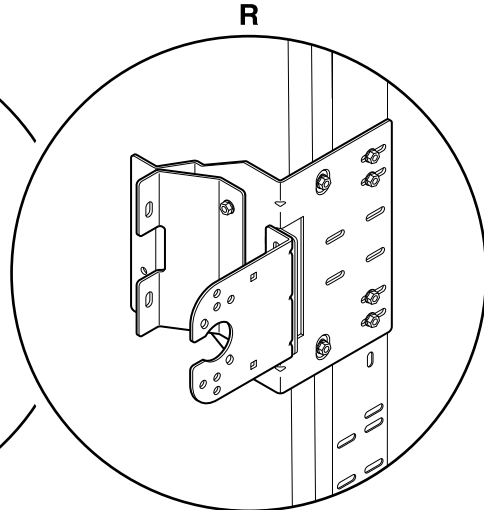
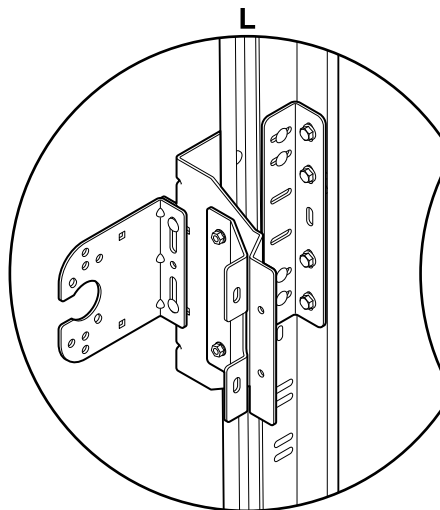

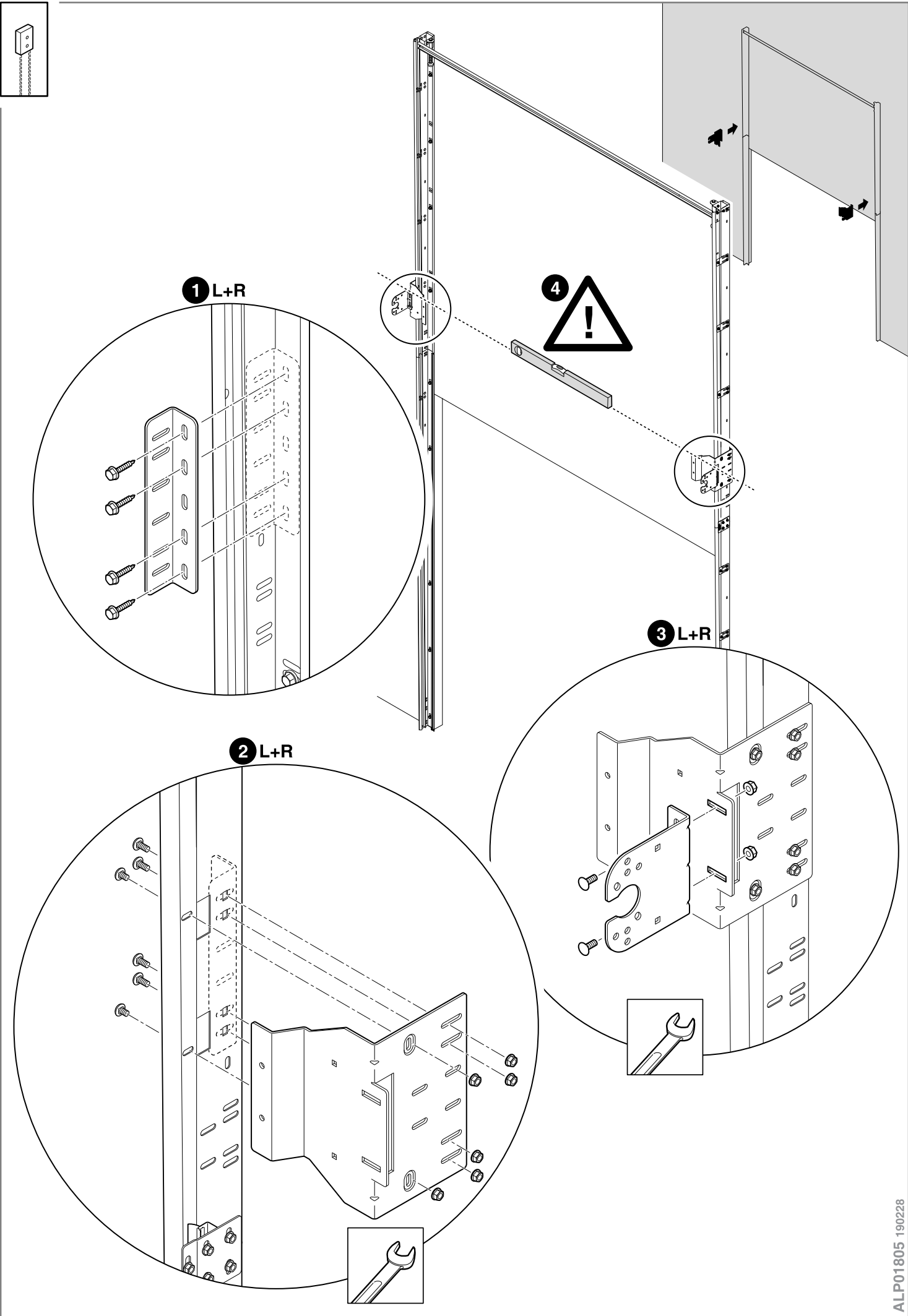
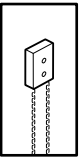

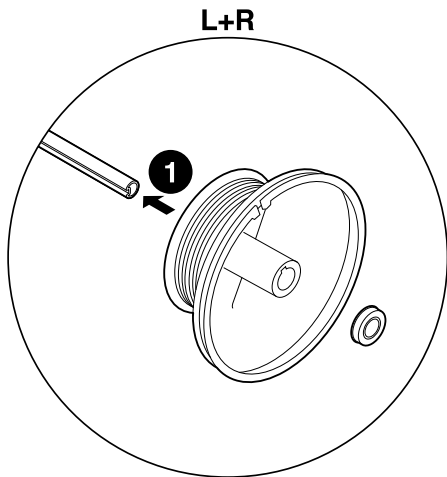
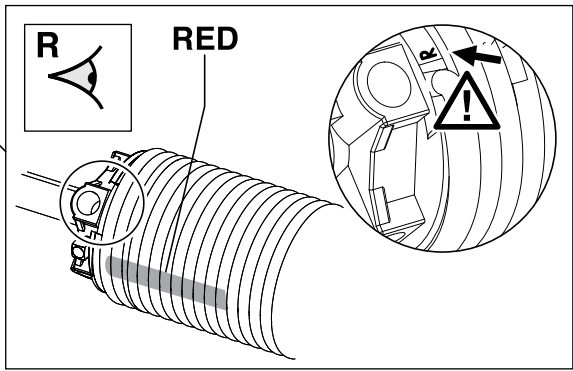
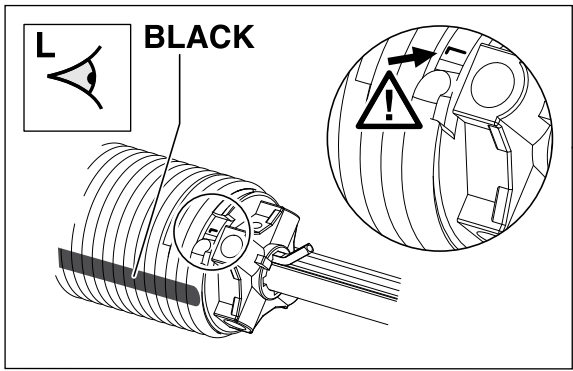
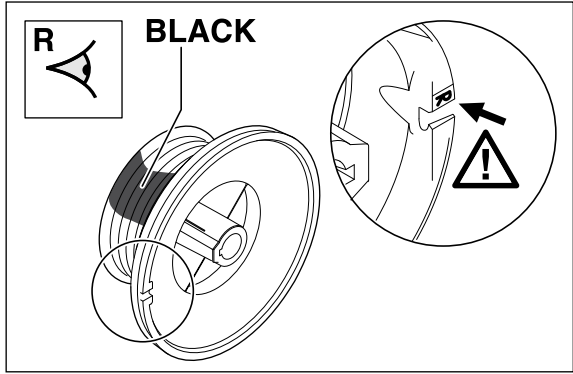
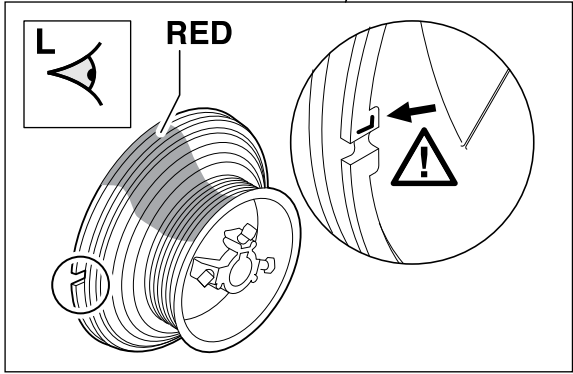
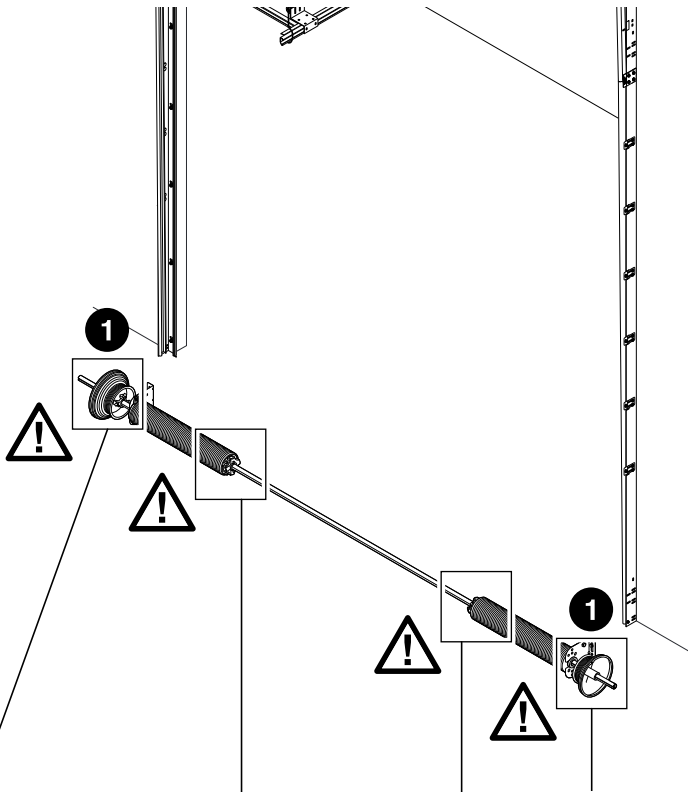
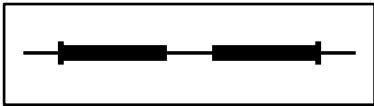

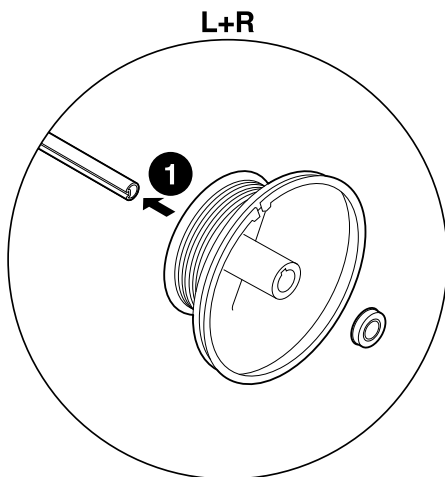
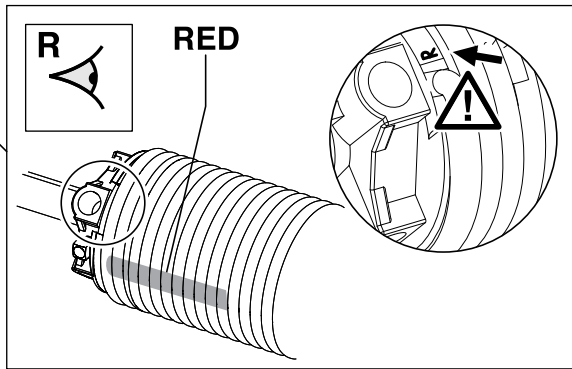
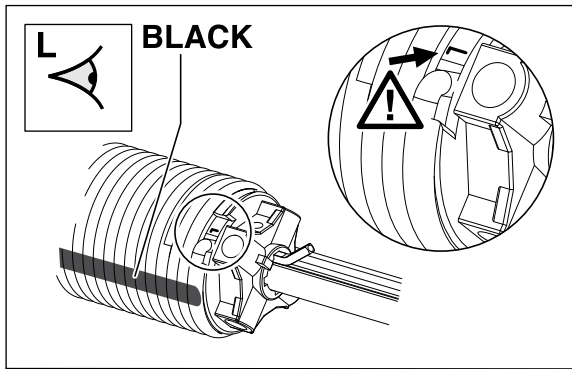
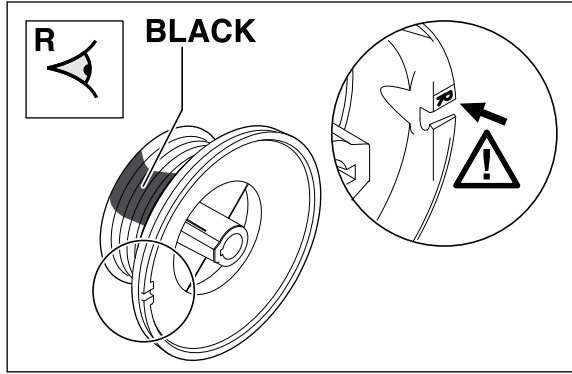
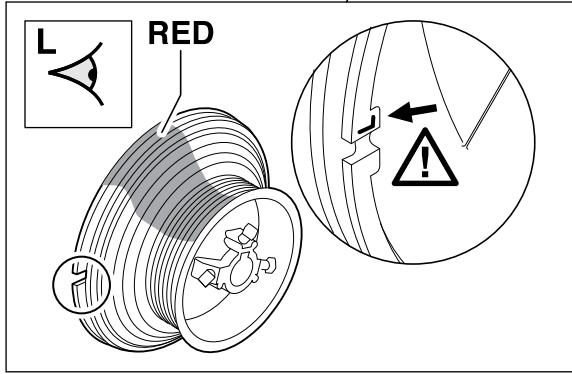
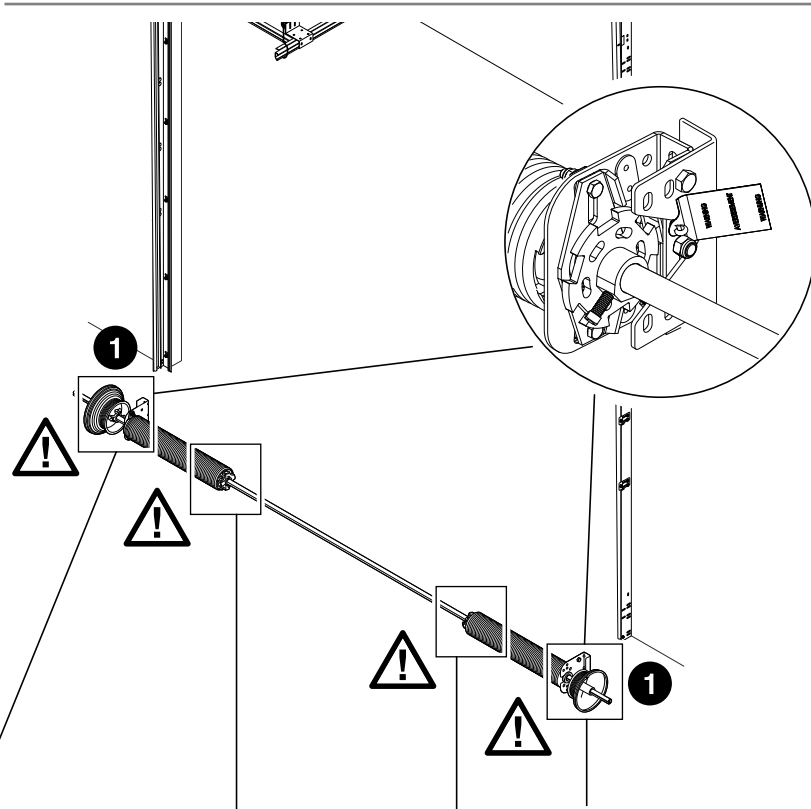
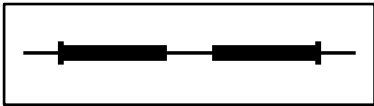

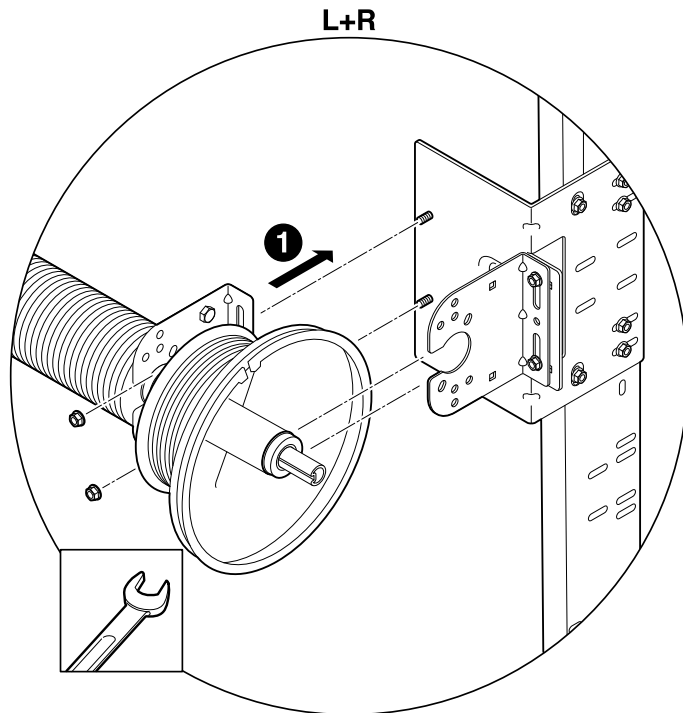
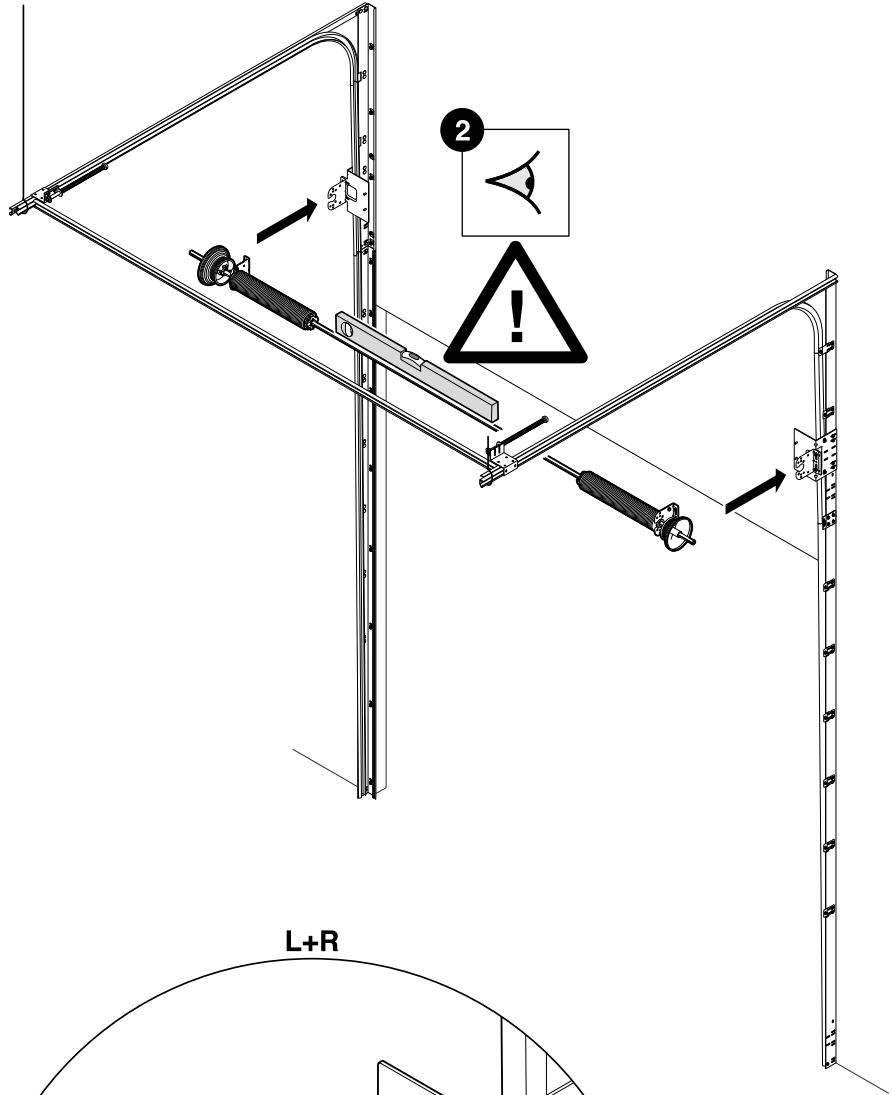
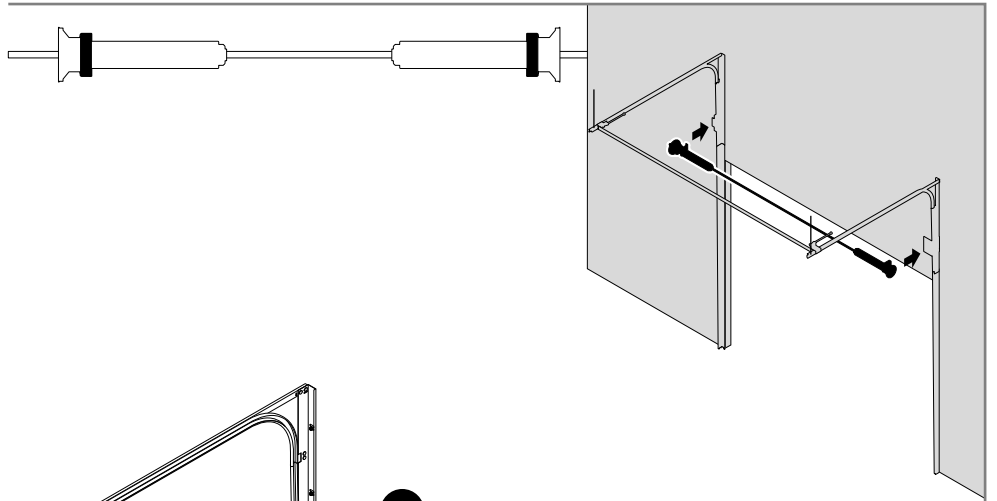
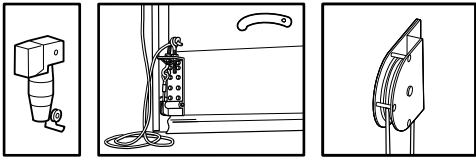

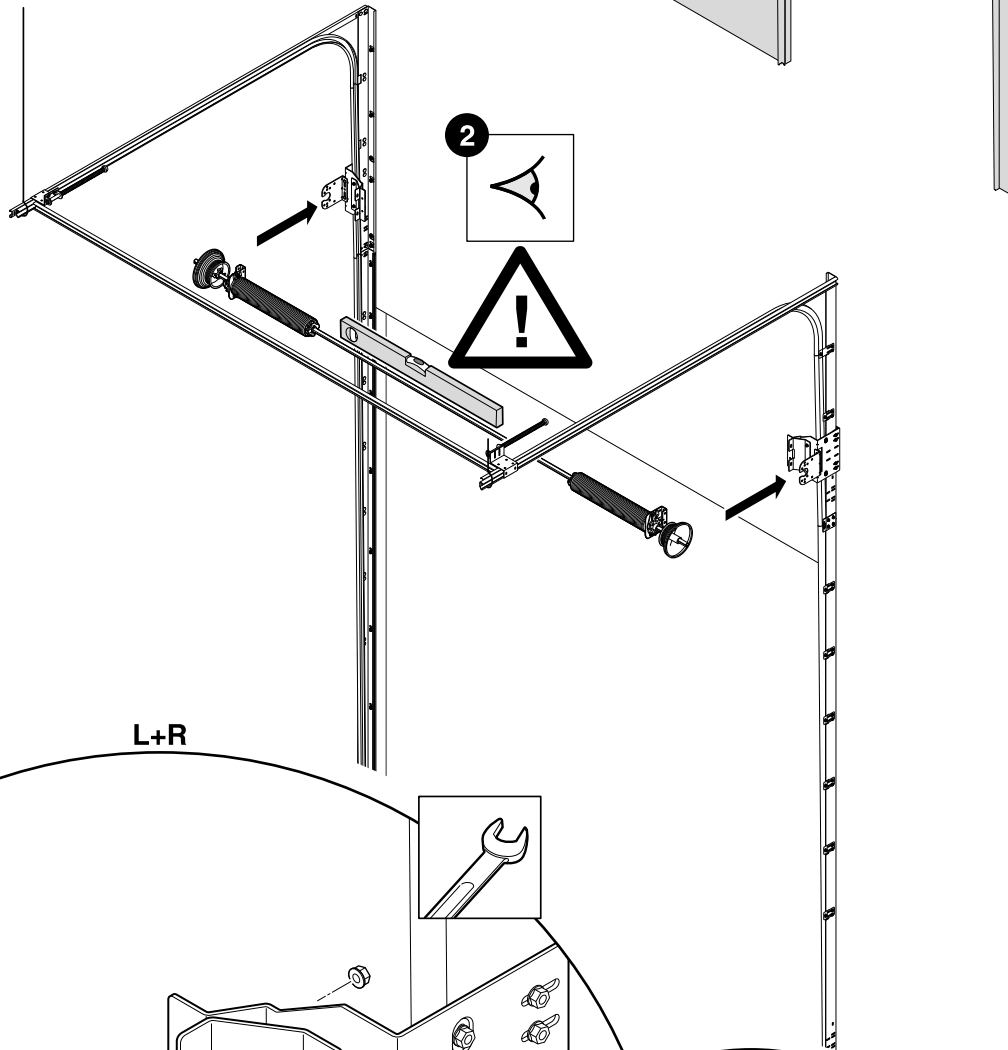
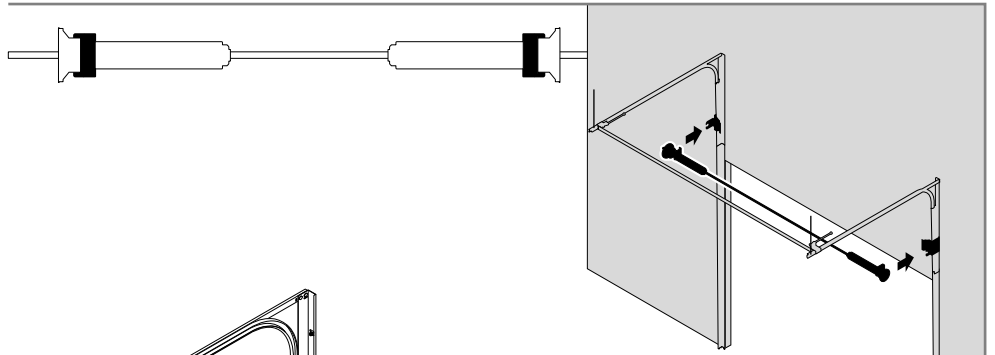
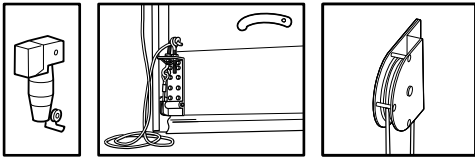

L+R

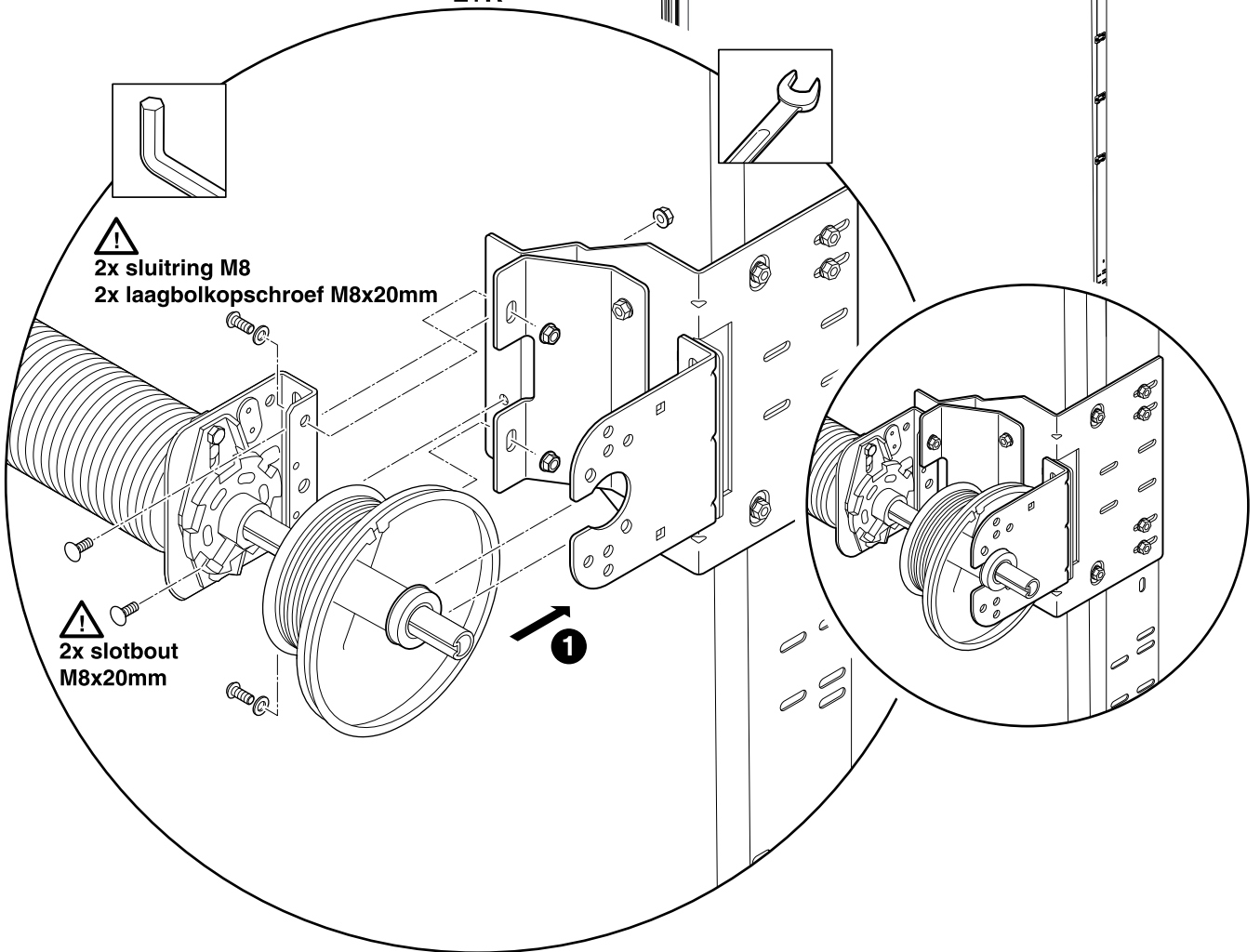

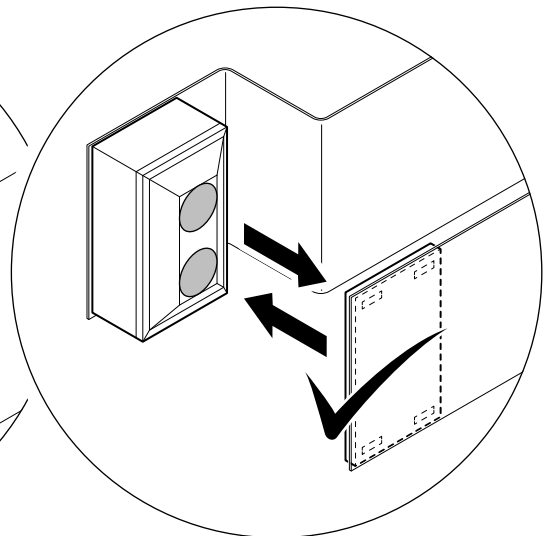
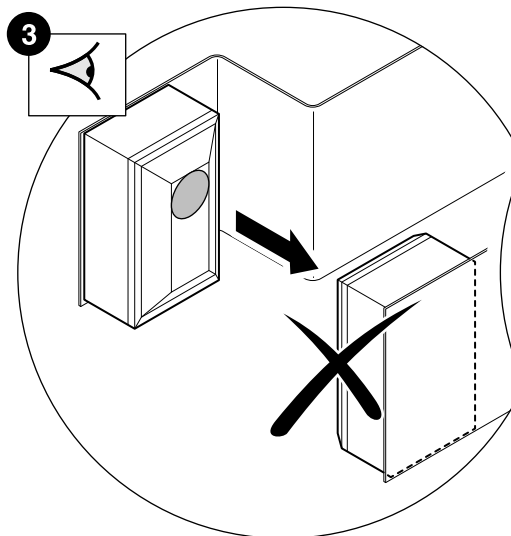
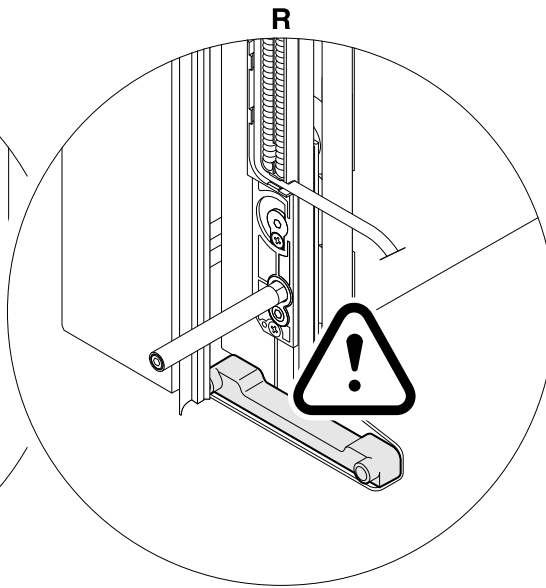
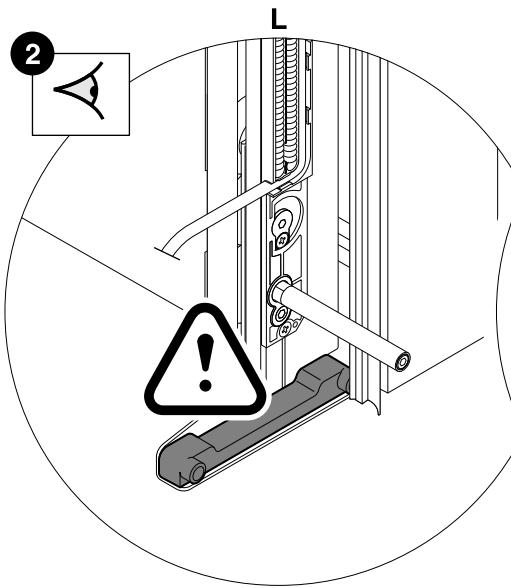
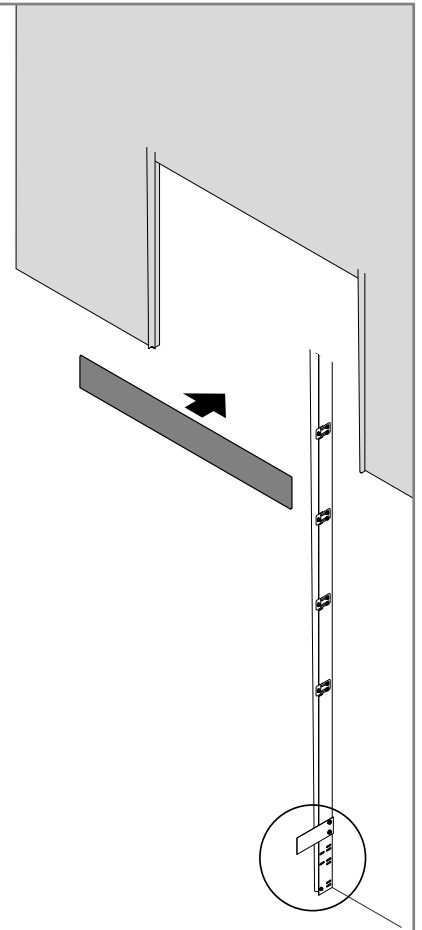
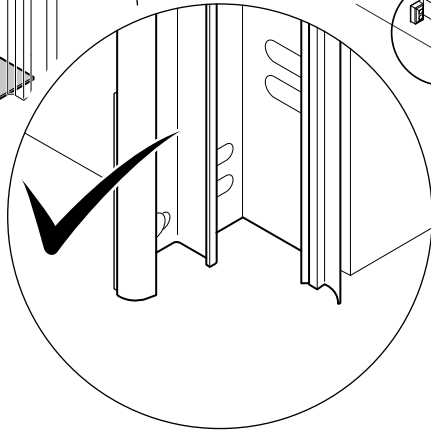
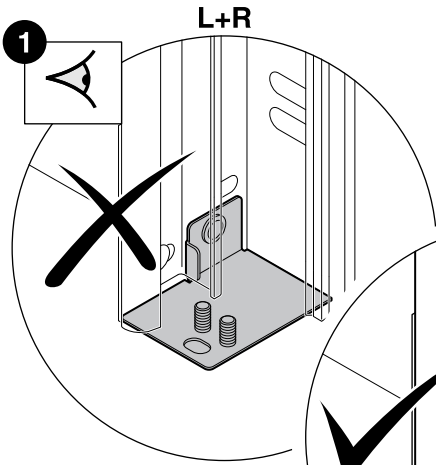
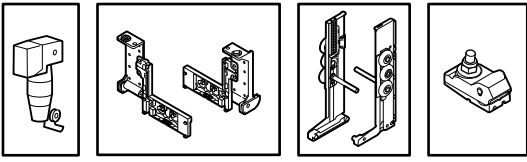

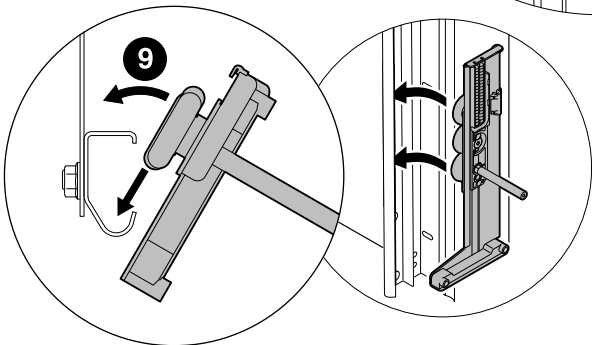
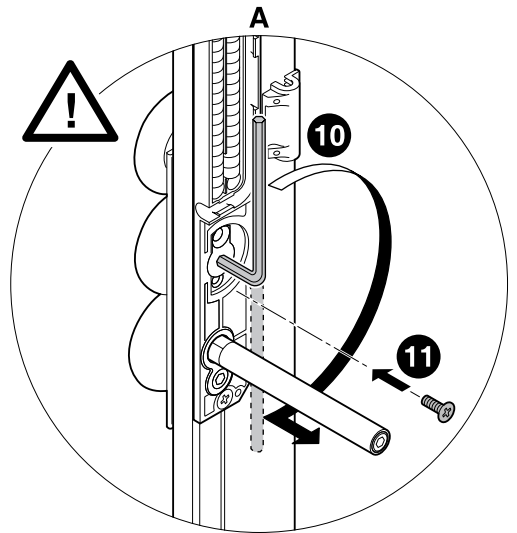
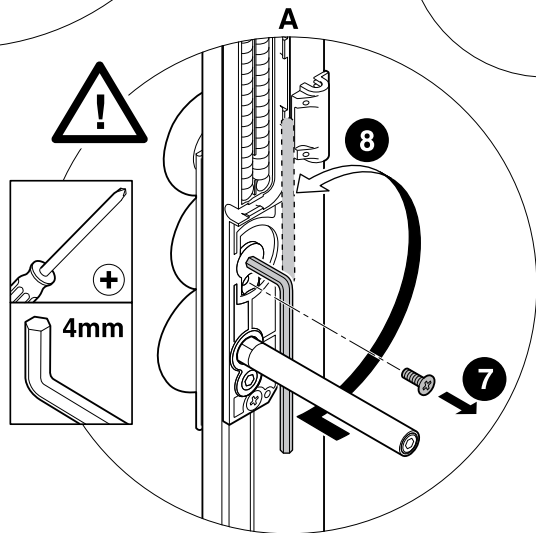
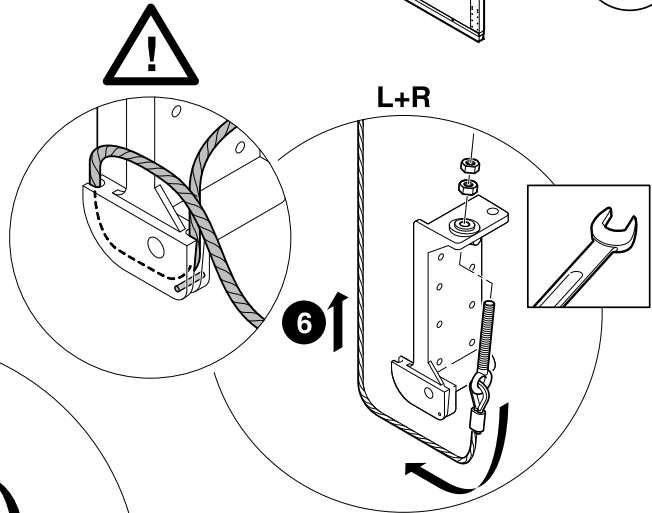
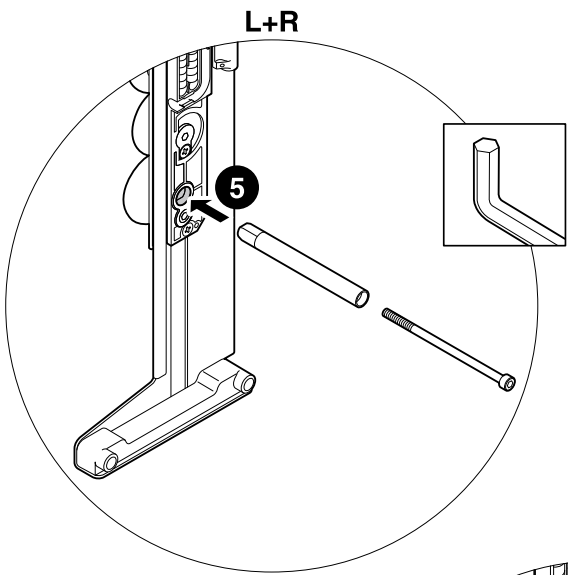
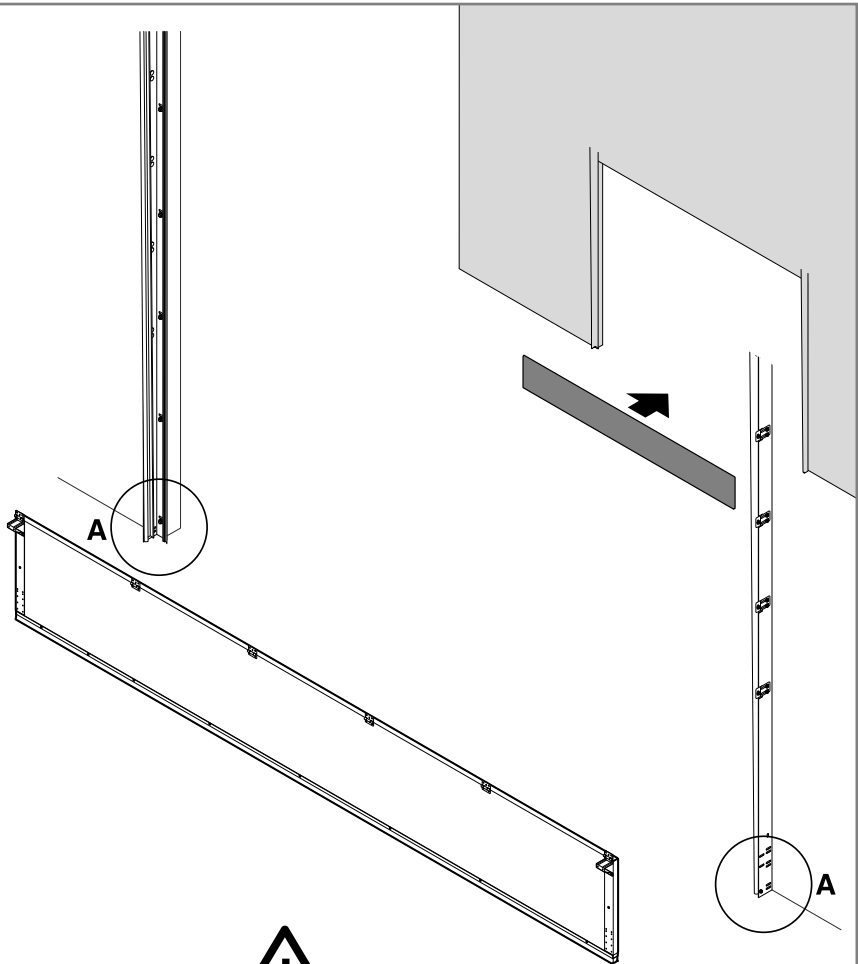
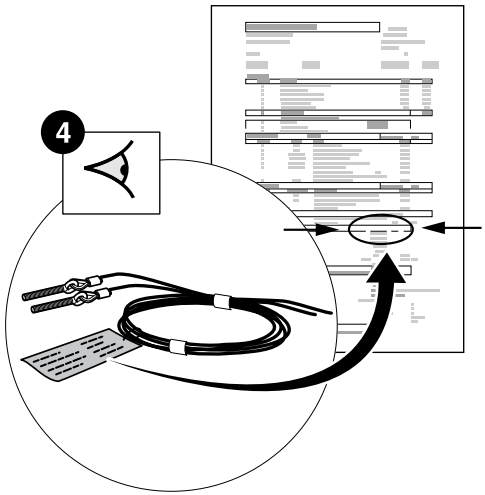
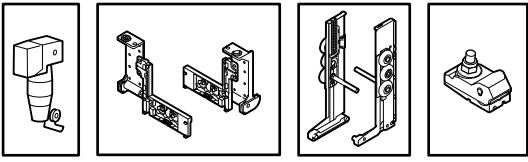

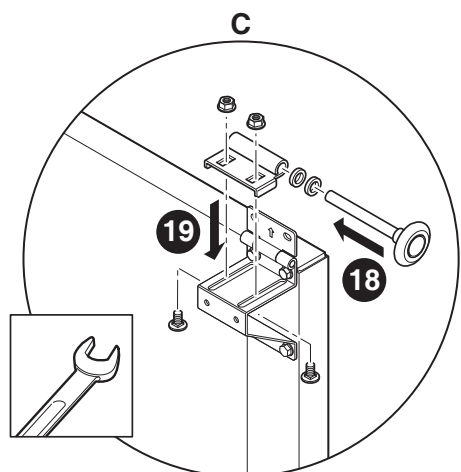
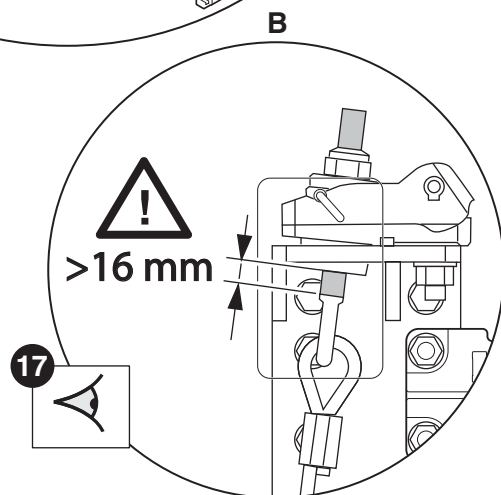
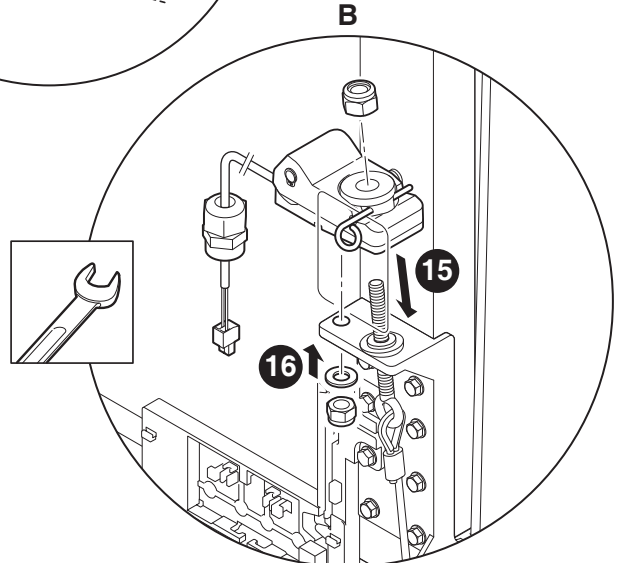
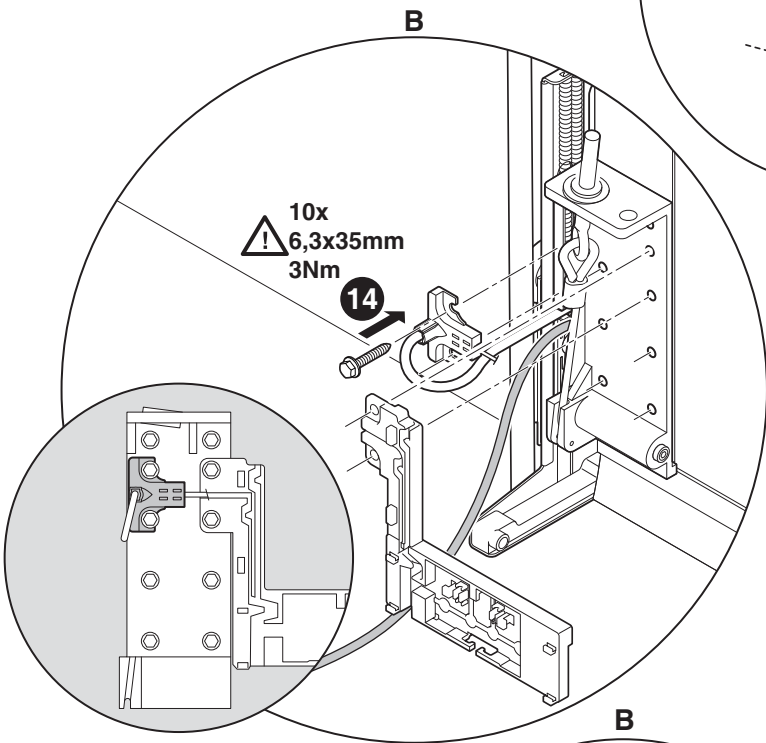
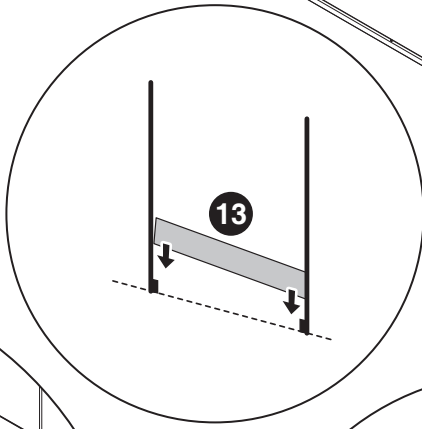
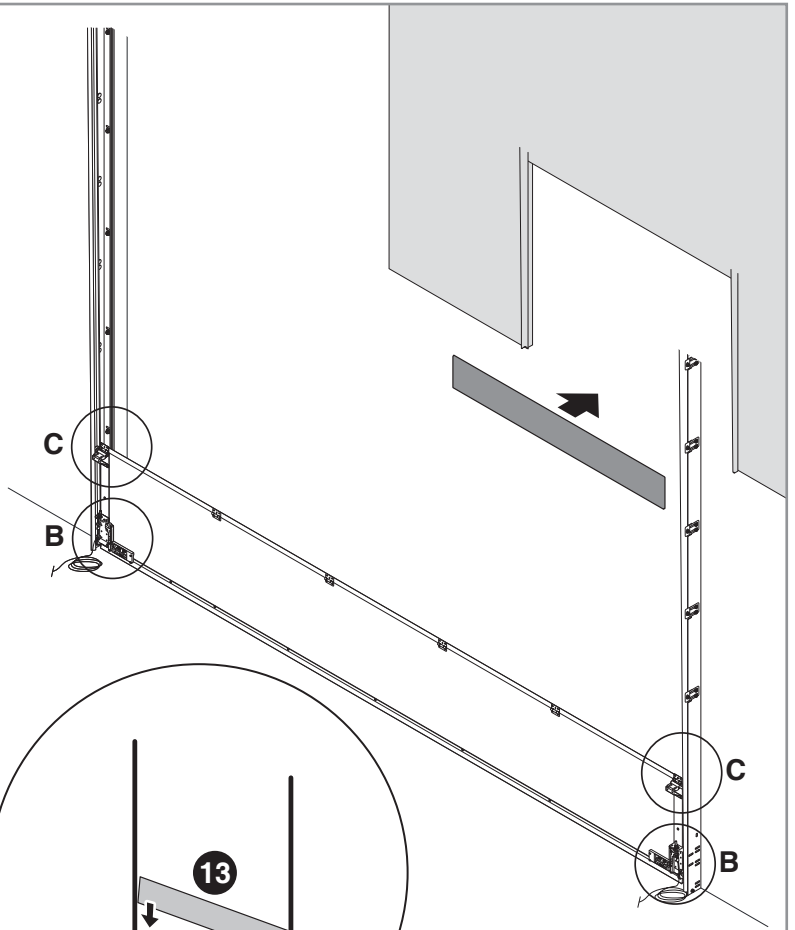
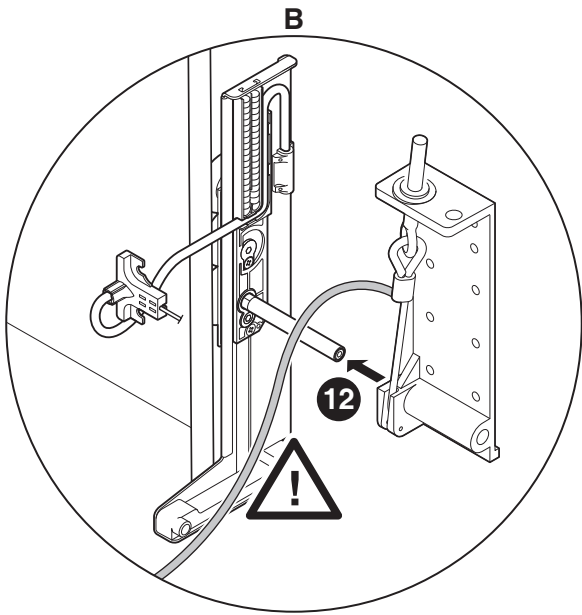
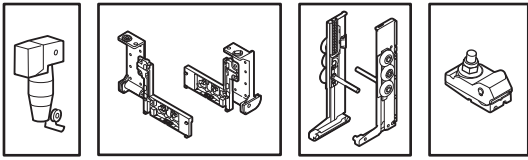

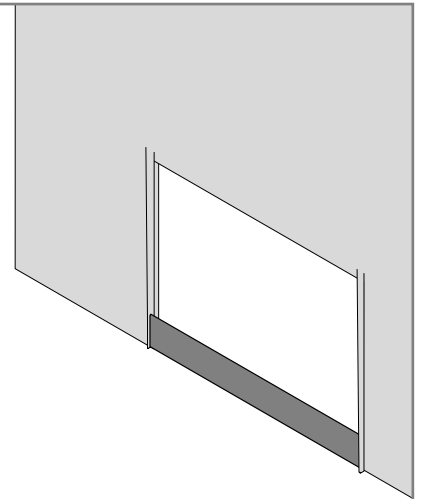
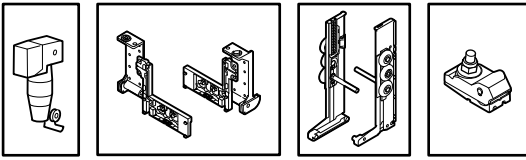

IMPORTANT INFORMATION

nl Bij deuren met **Loopdeur Drempel 22 mm** in verband met een **voorlopende fotocelbeveiliging**, moet in programmeer punt 2.1 de optie 2 gekozen worden!



Als nodig kan onder programmeer punt 1.5 het schakelpunt (hoogte) van het deactiveren van de voorlopende fotocelbewaking veranderd worden!

Deze hoogte mag niet hoger dan 5,0 cm zijn!

de Bei Toren mit **Schlupfürschwelle 22 mm** mit einer **voreilender Lichtschanke**, muss unter Programmierpunkt 2.1 die Option 2 gewählt werden!



Wenn nötig kann unter Programmierpunkt 1.5 der Schaltpunkt (die Höhe) zur Deaktivierung der voreilenden Lichtschanke verändert werden!

Die Höhe darf 5,0 cm nicht überschreiten!

en Doors with **wicket door with a threshold 22 mm** in company with a **leading photocell**, you have to adjust program point 2.1 option 2!



If necessary you can extend the switch point (height) for deactivating the leading photocell under program point 1.5!

It's not allowed to adjust this point above 5,0 cm!

fr Pour des portes avec **portillon à hauteur de seuil 22 mm**, avec une **cellule photoélectrique avancée**, il faut choisir au point de programmation 2.1 l'option 2 !



Si nécessaire, on peut varier la position de commutation (la hauteur) au point de programmation 1.5 pour la déactivation de la cellule!

La hauteur ne peut pas dépasser 5,0 cm!

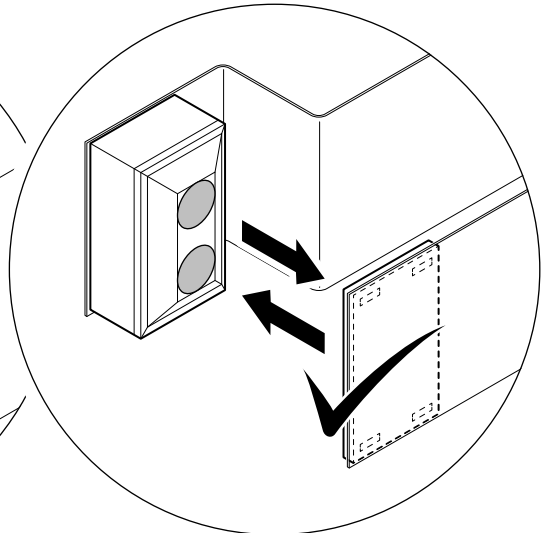
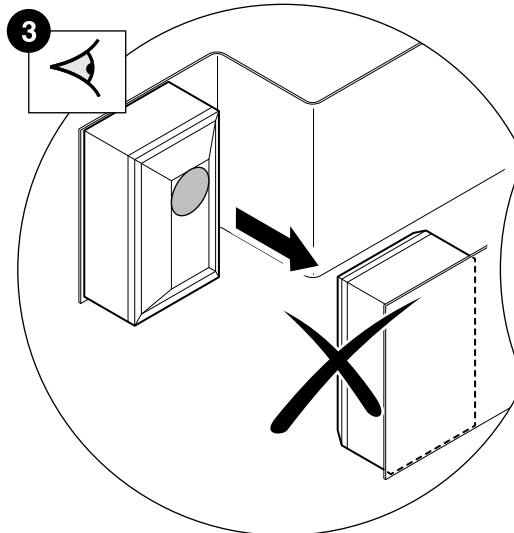
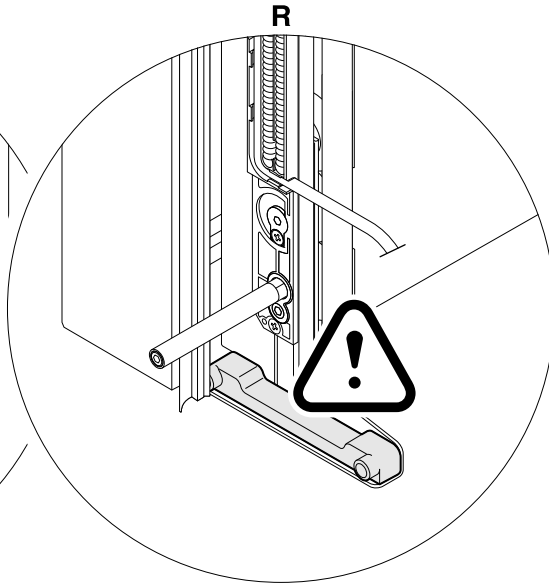
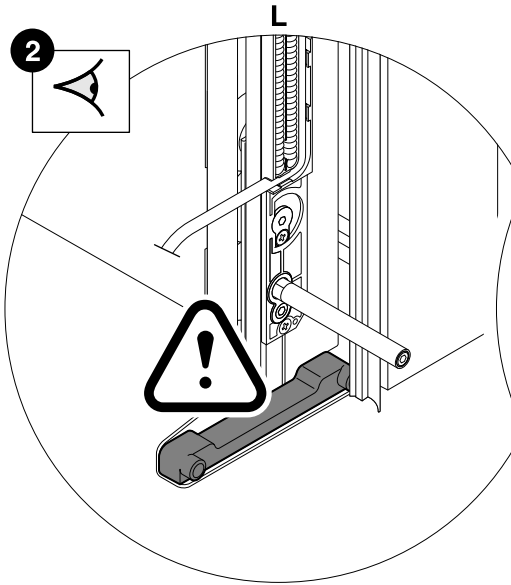
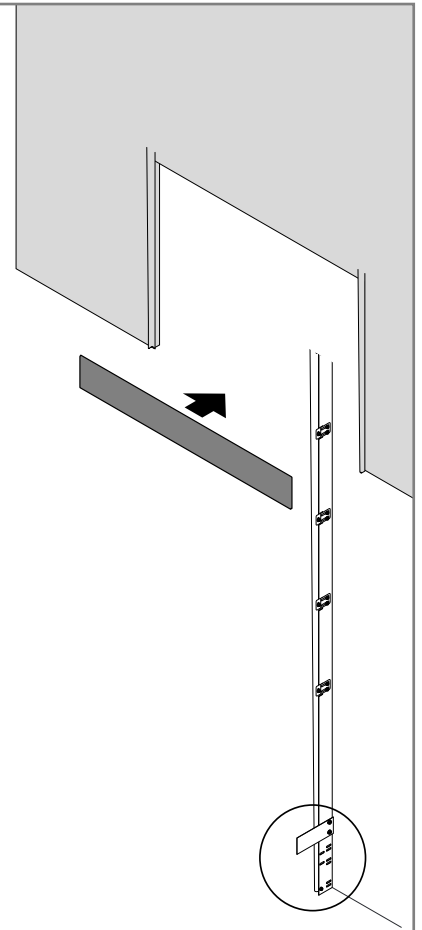
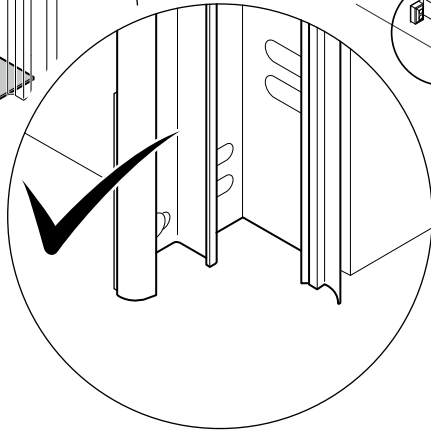
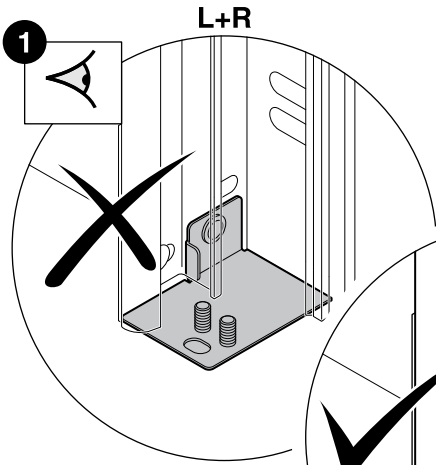
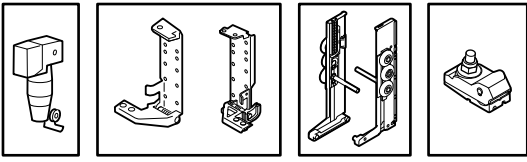

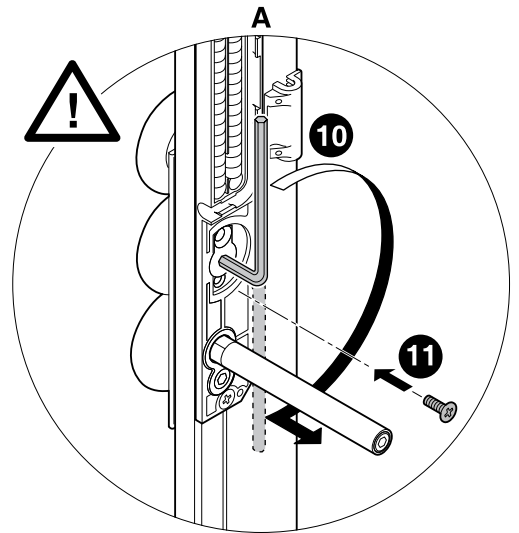
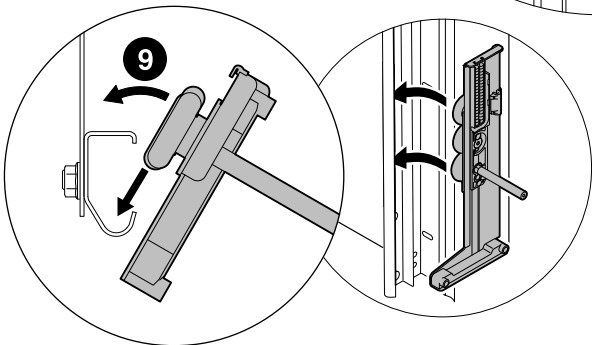
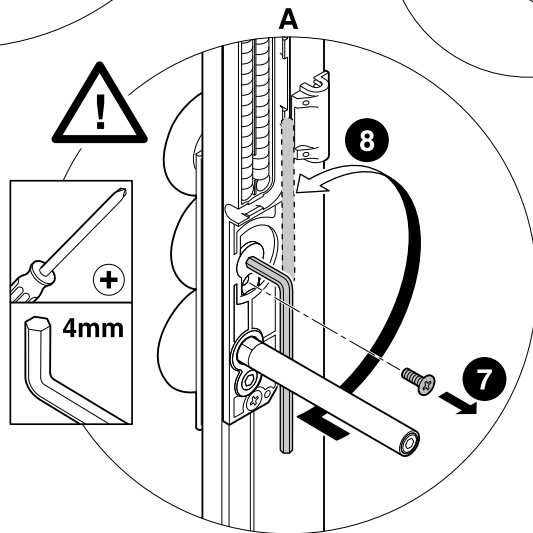
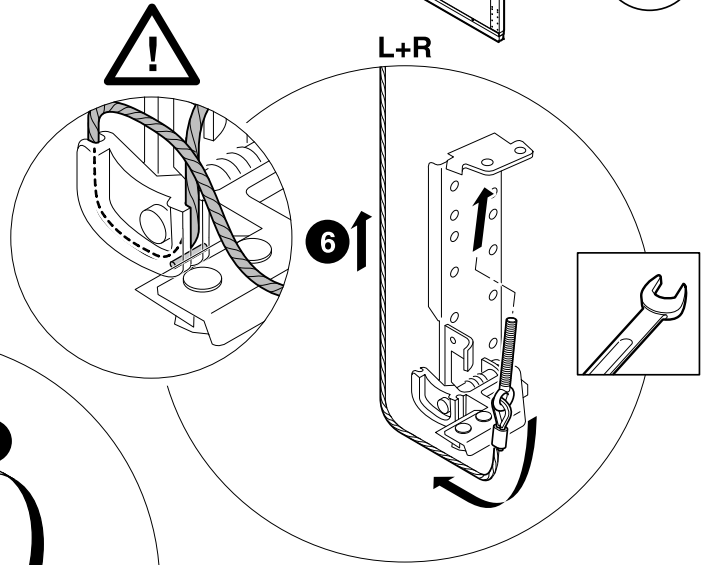
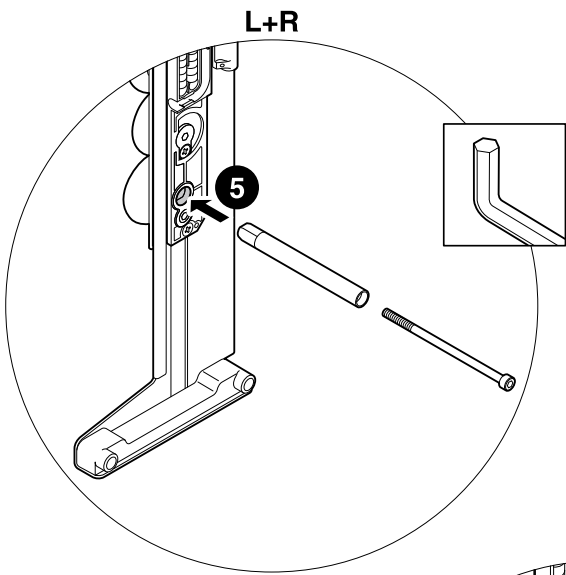
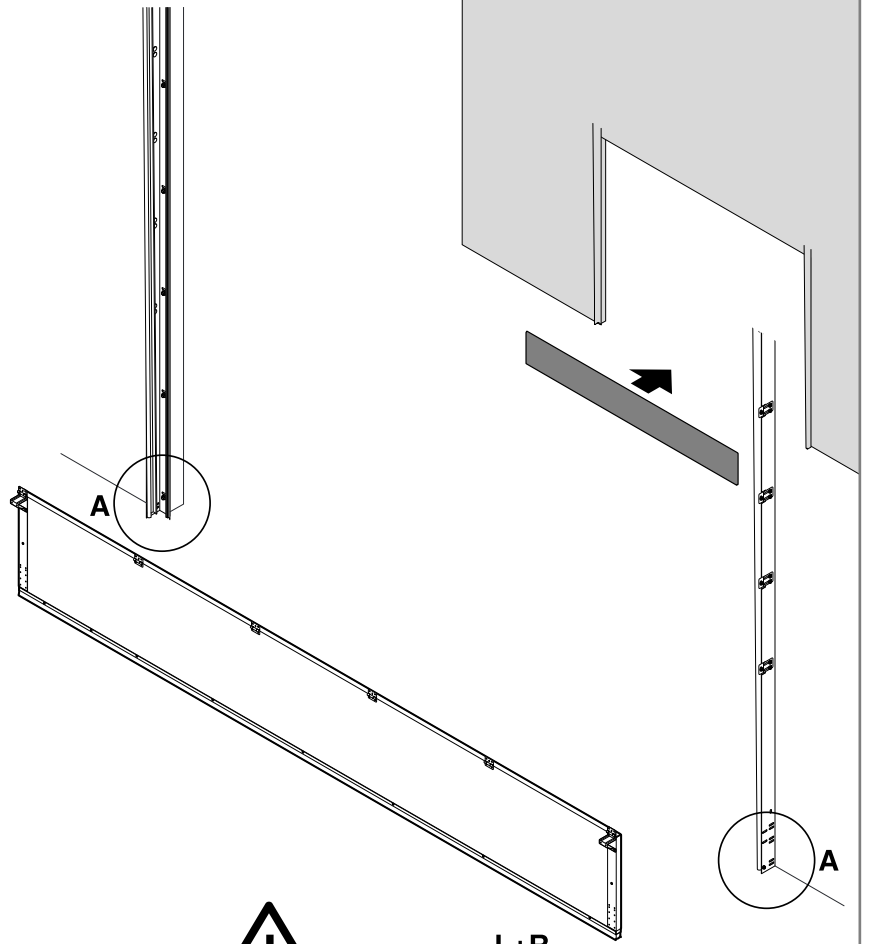
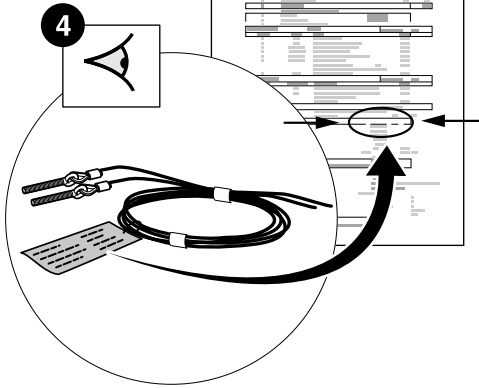
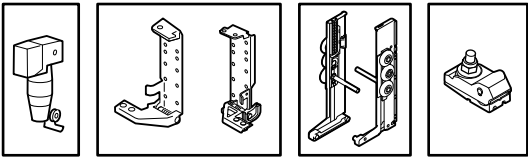

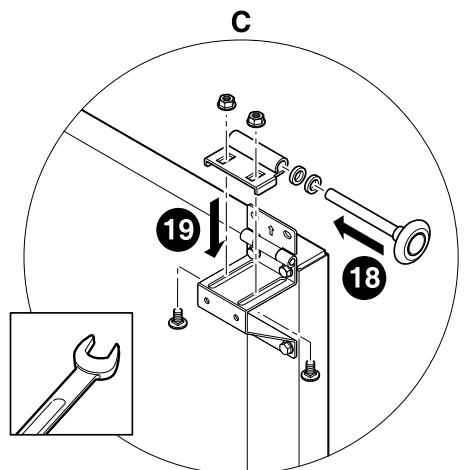
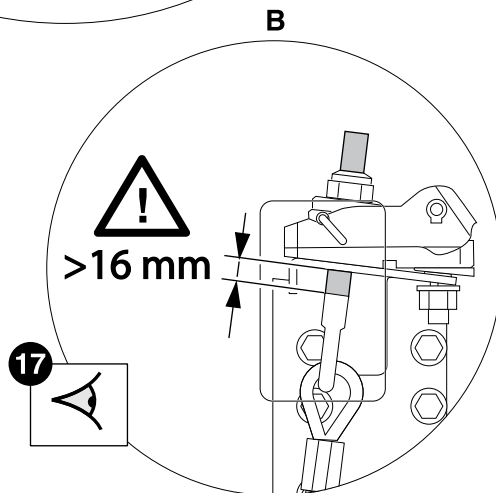
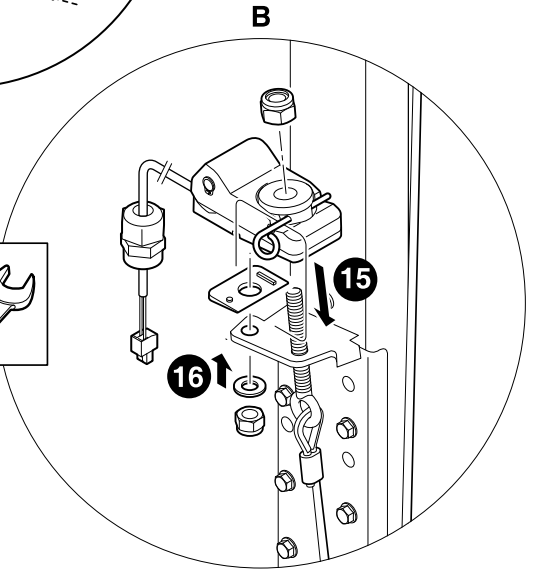
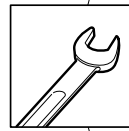
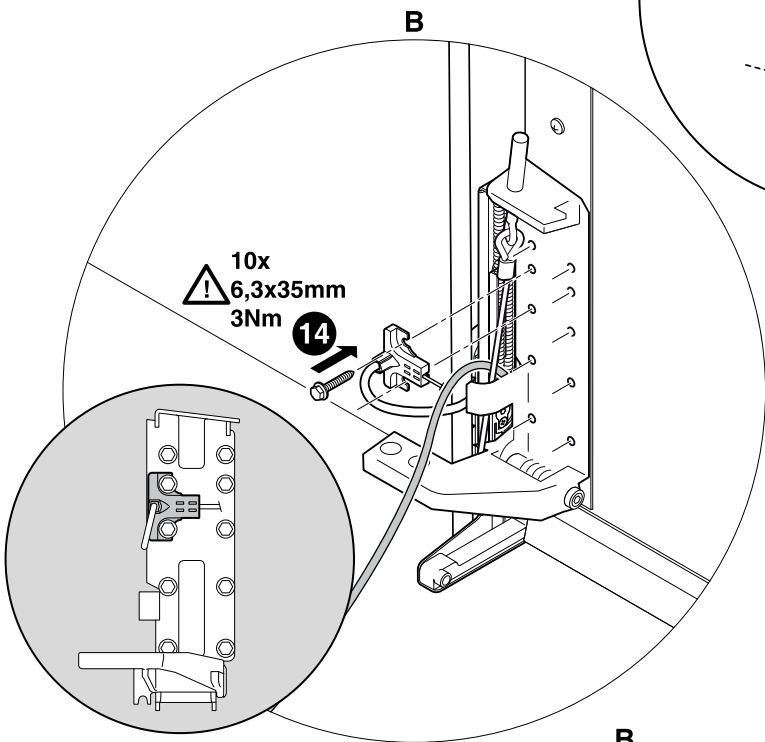
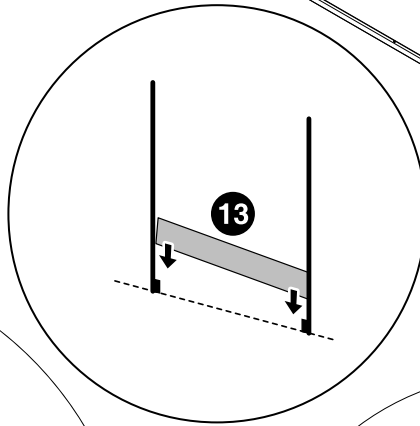
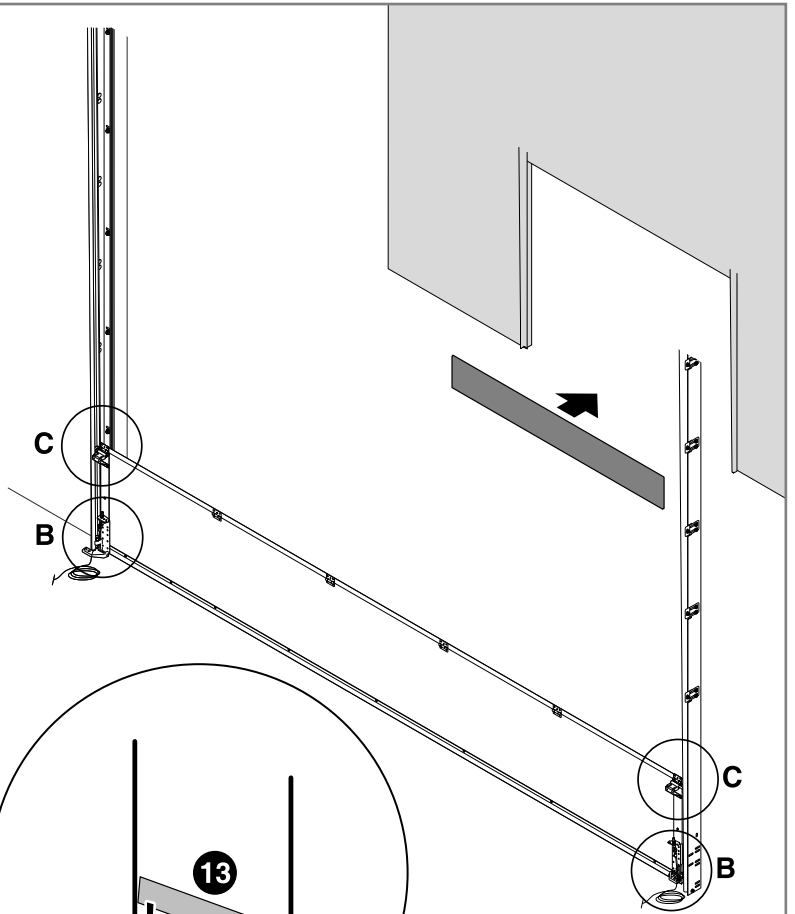
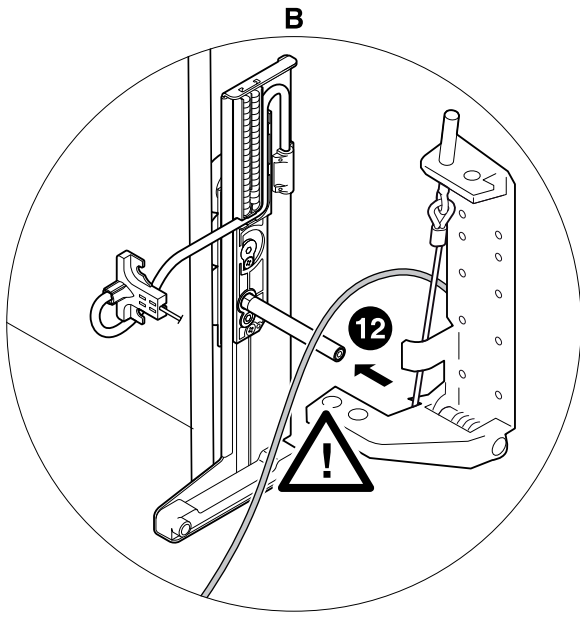
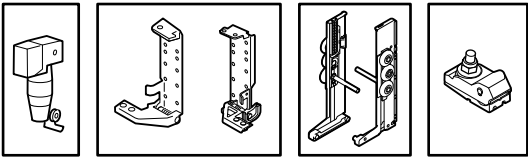

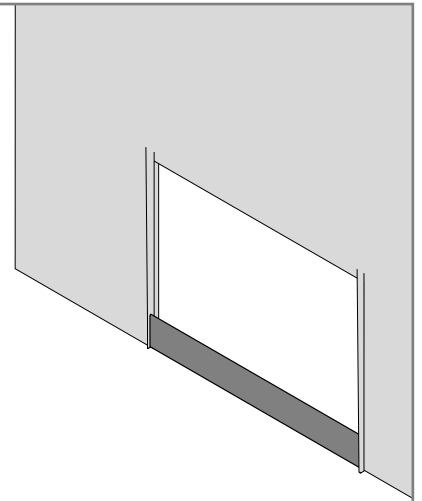
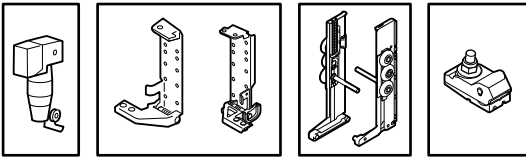





IMPORTANT INFORMATION

- nl** Bij deuren met **Loopdeur Drempel 22 mm** in verband met een **voorlopende fotocelbeveiliging**, moet in programmeer punt 2.1 de optie 2 gekozen worden!
-  Als nodig kan onder programmeer punt 1.5 het schakelpunt (hoogte) van het deactiveren van de voorlopende fotocelbewaking veranderd worden!
Deze hoogte mag niet hoger dan 5,0 cm zijn!
- de** Bei Toren mit **Schlupfürschwelle 22 mm** mit einer **voreilender Lichtschanke**, muss unter Programmierpunkt 2.1 die Option 2 gewählt werden!
-  Wenn nötig kann unter Programmierpunkt 1.5 der Schaltpunkt (die Höhe) zur Deaktivierung der voreilenden Lichtschanke verändert werden!
Die Höhe darf 5,0 cm nicht überschreiten!
- en** Doors with **wicket door with a threshold 22 mm** in company with a **leading photocell**, you have to adjust program point 2.1 option 2!
-  If necessary you can extend the switch point (height) for deactivating the leading photocell under program point 1.5!
It's not allowed to adjust this point above 5,0 cm!
- fr** Pour des portes avec **portillon à hauteur de seuil 22 mm**, avec une **cellule photoélectrique avancée**, il faut choisir au point de programmation 2.1 l'option 2 !
-  Si nécessaire, on peut varier la position de commutation (la hauteur) au point de programmation 1.5 pour la désactivation de la cellule!
La hauteur ne peut pas dépasser 5,0 cm!

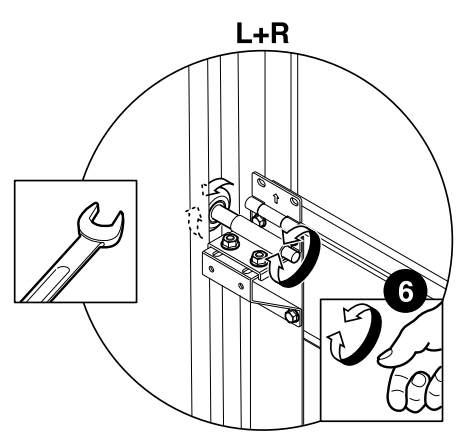
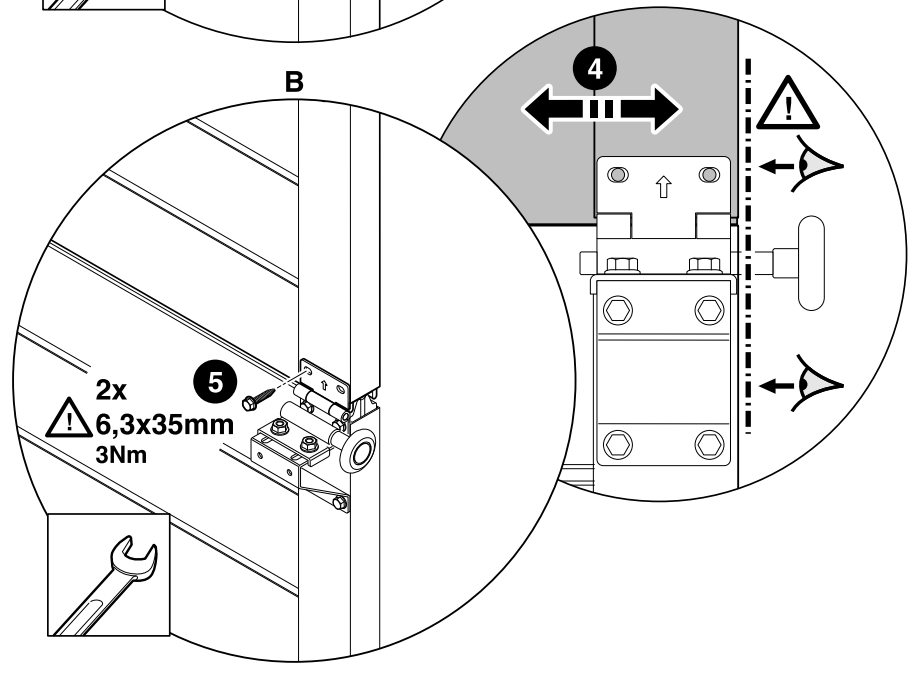
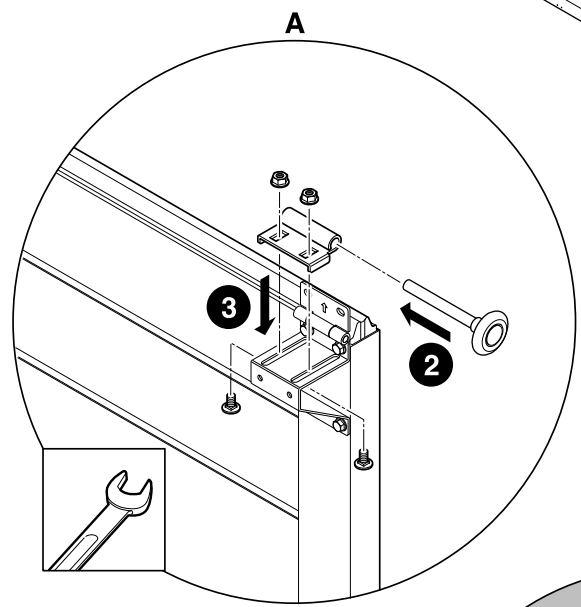
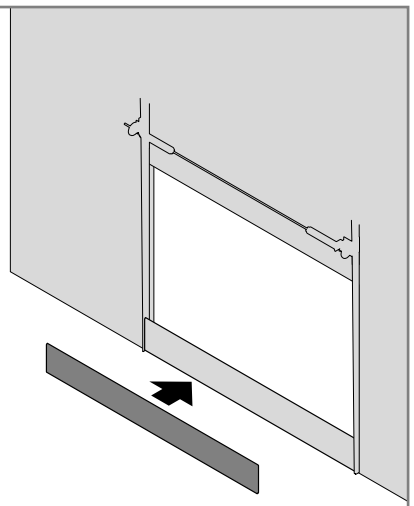
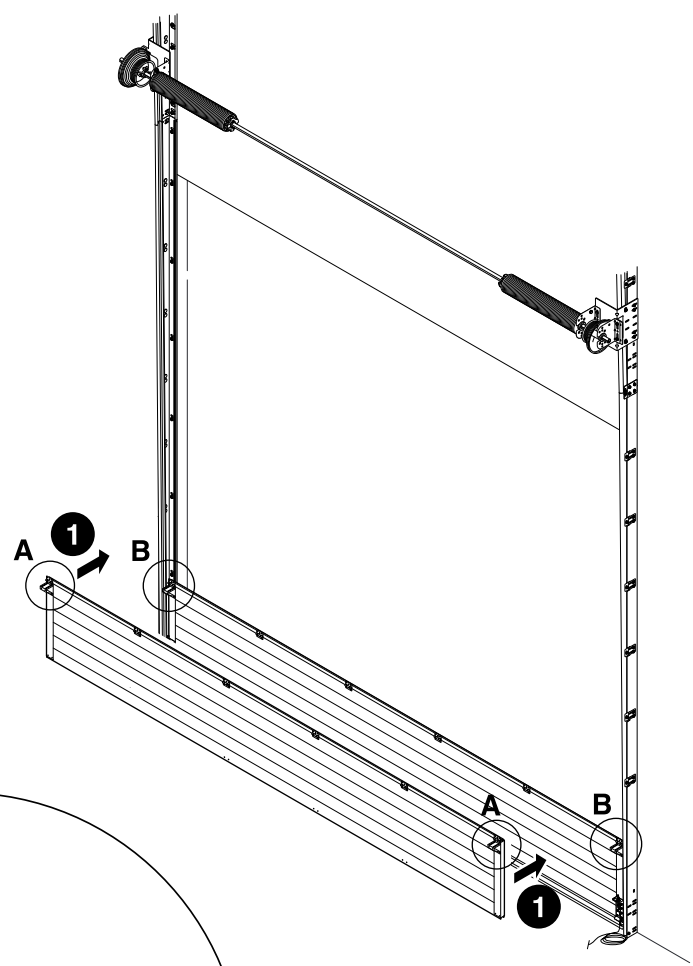

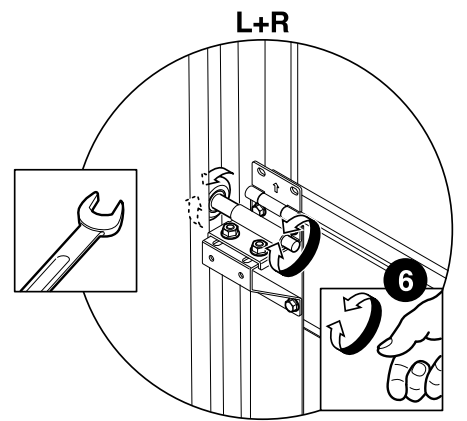
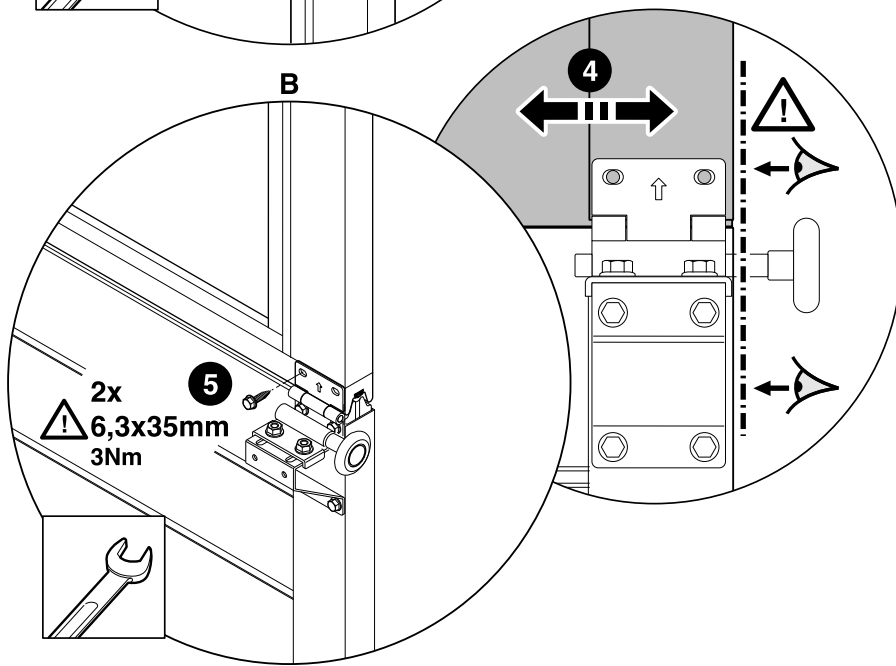
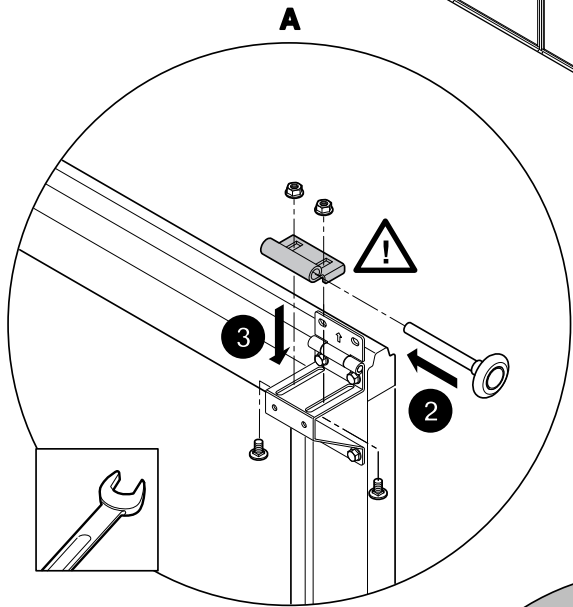
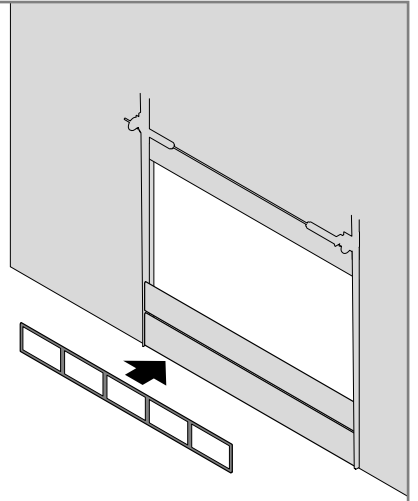
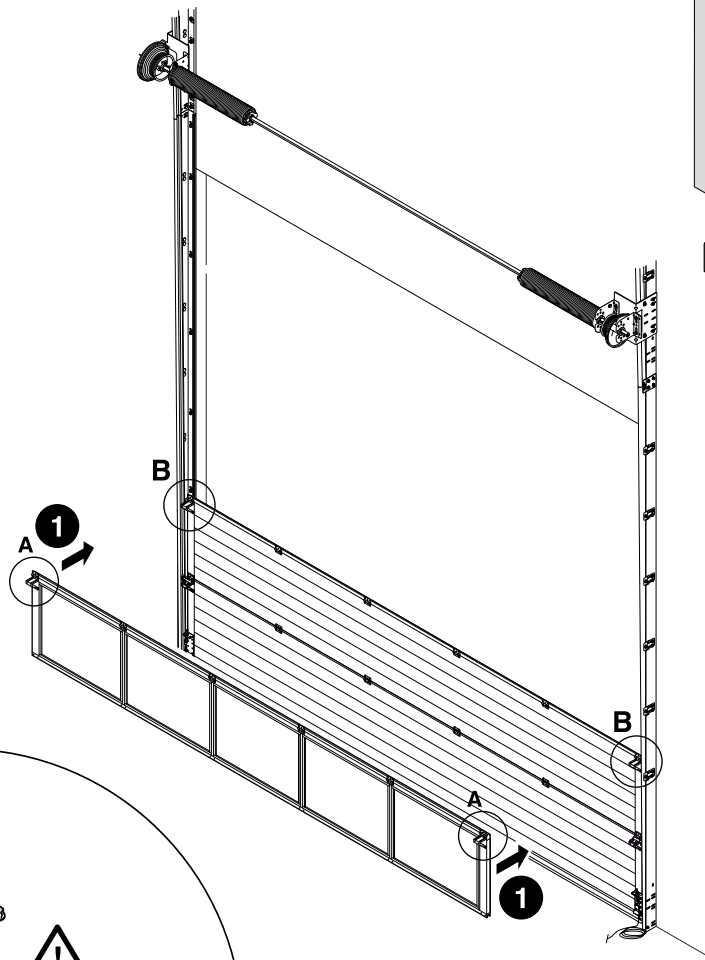

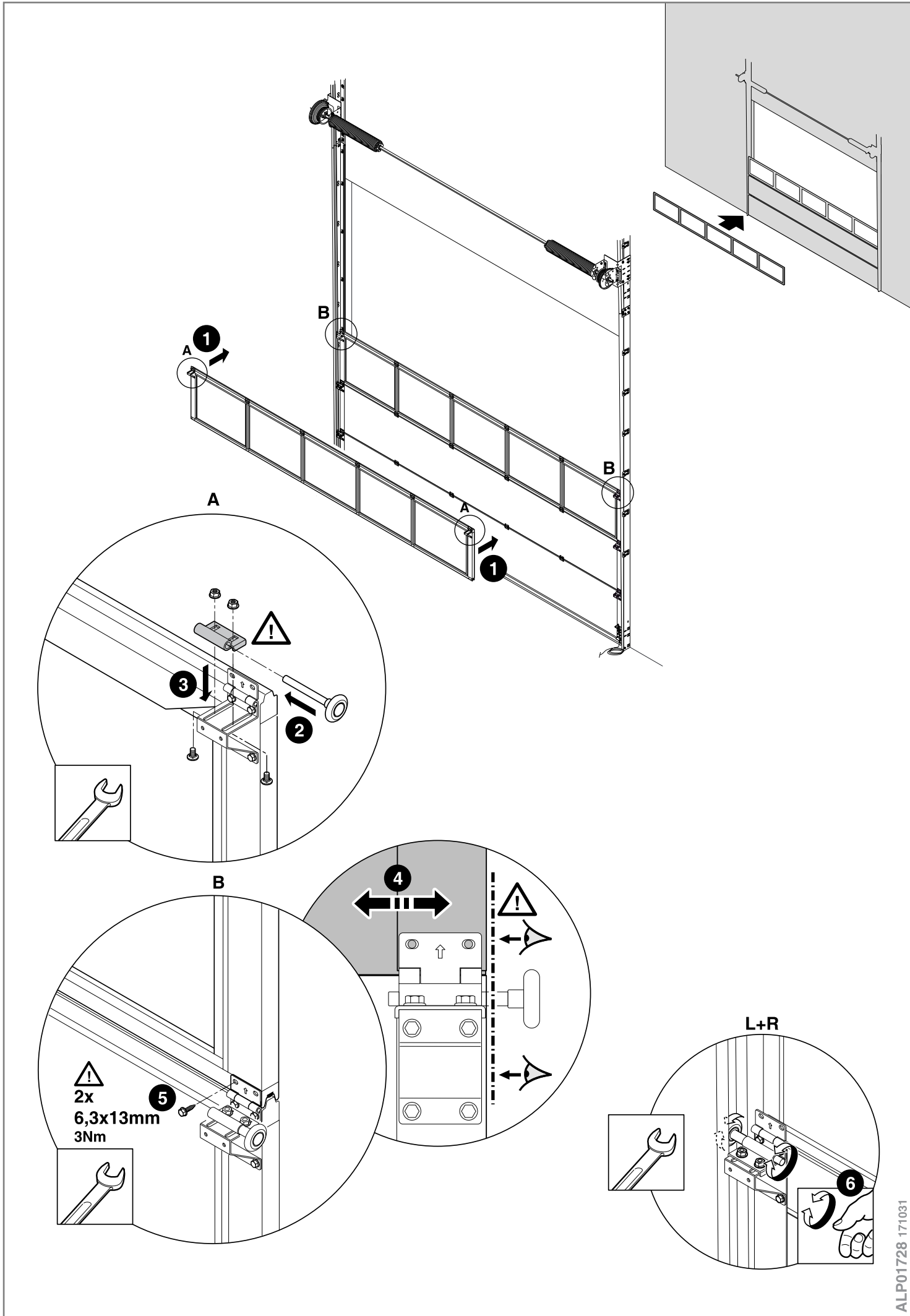

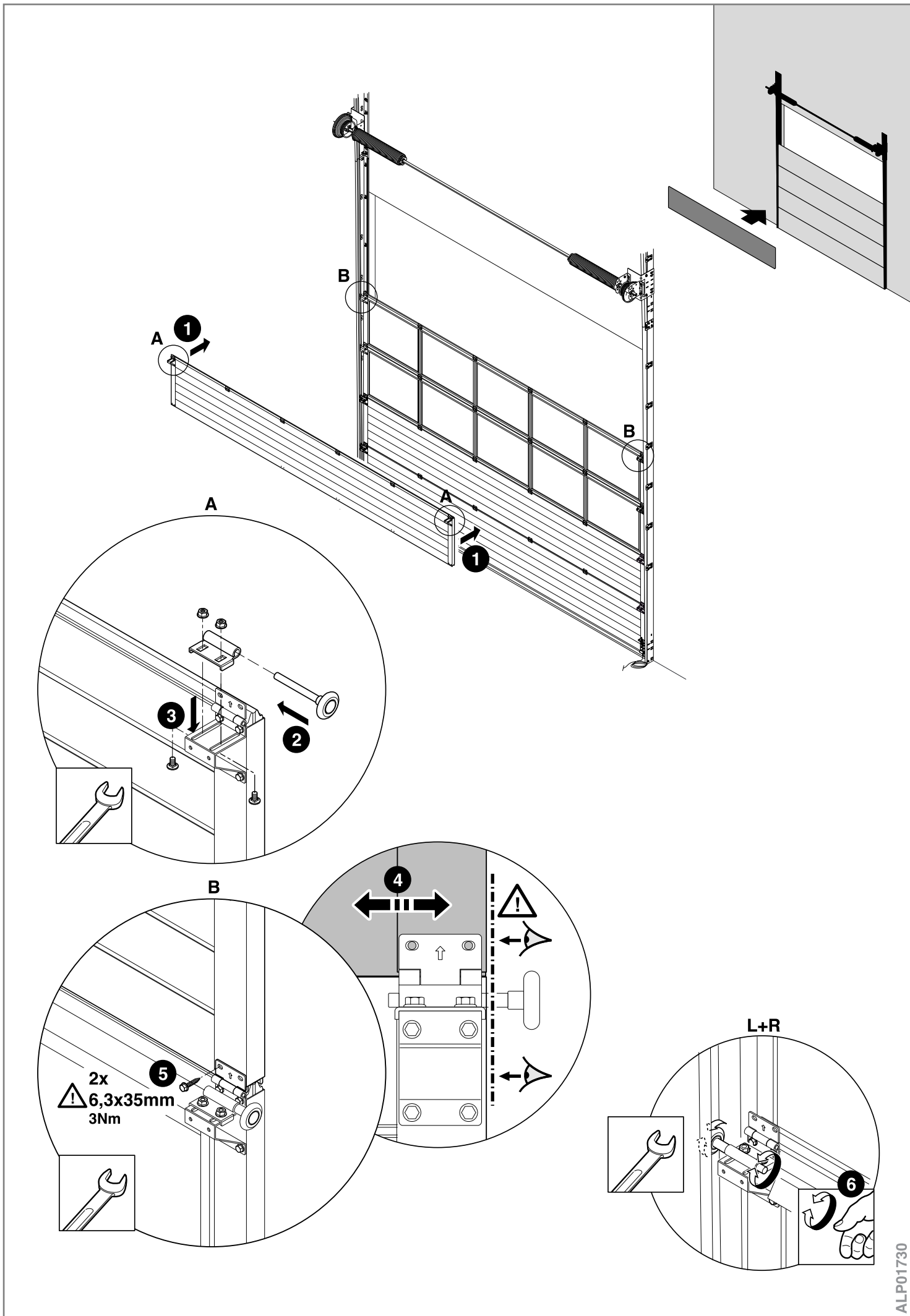

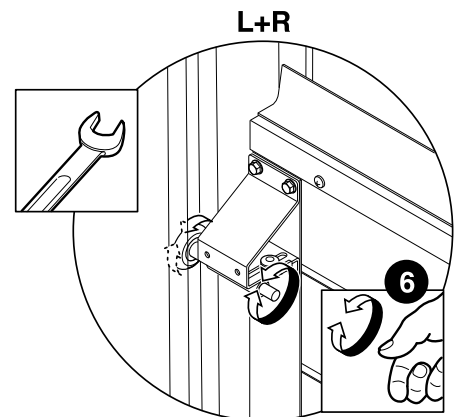
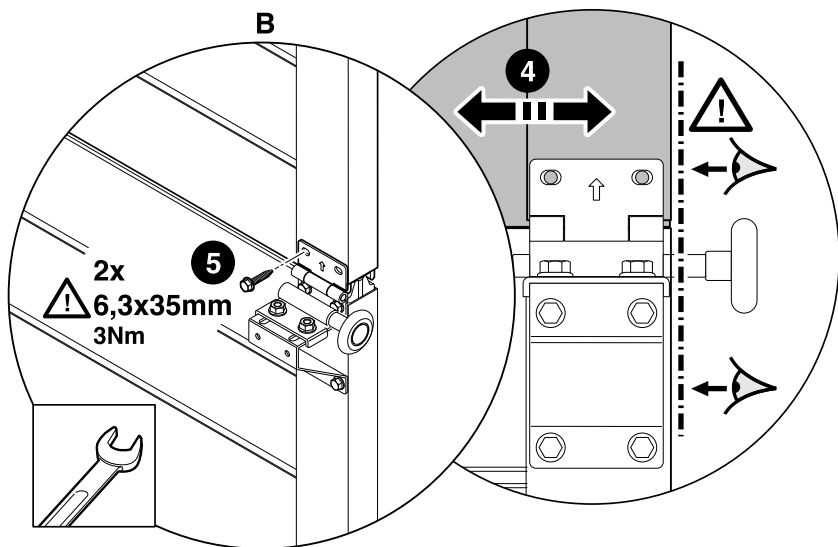
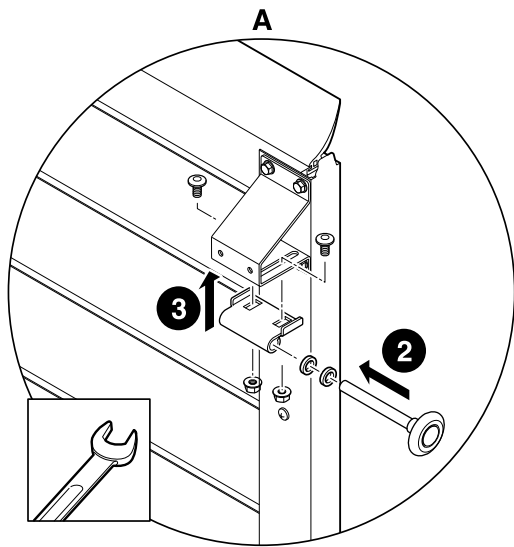
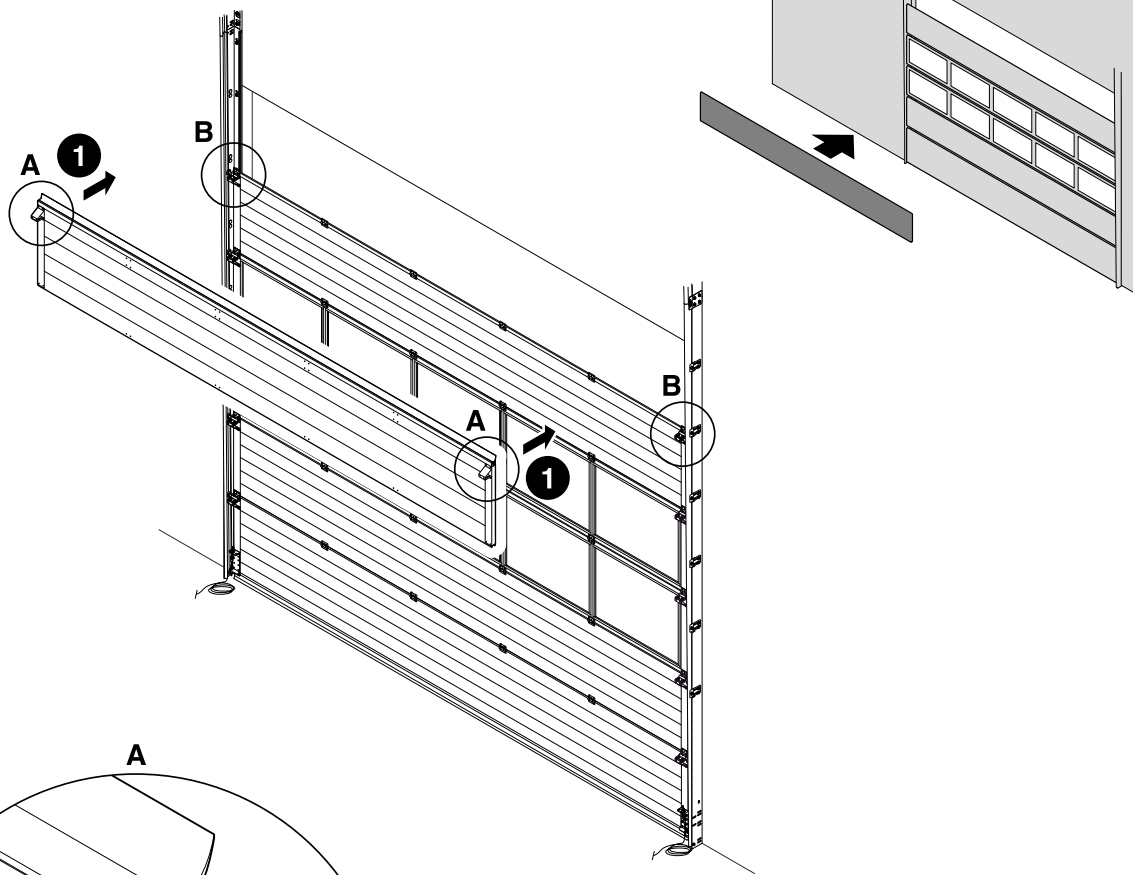

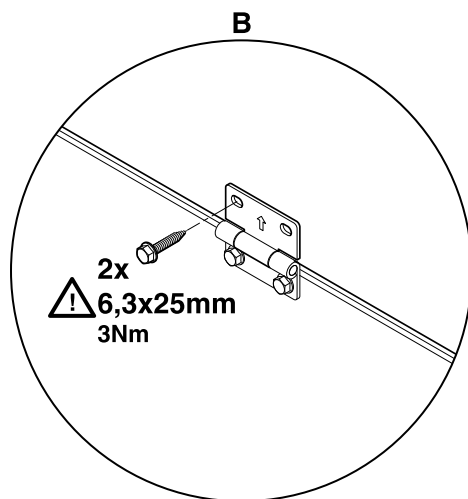
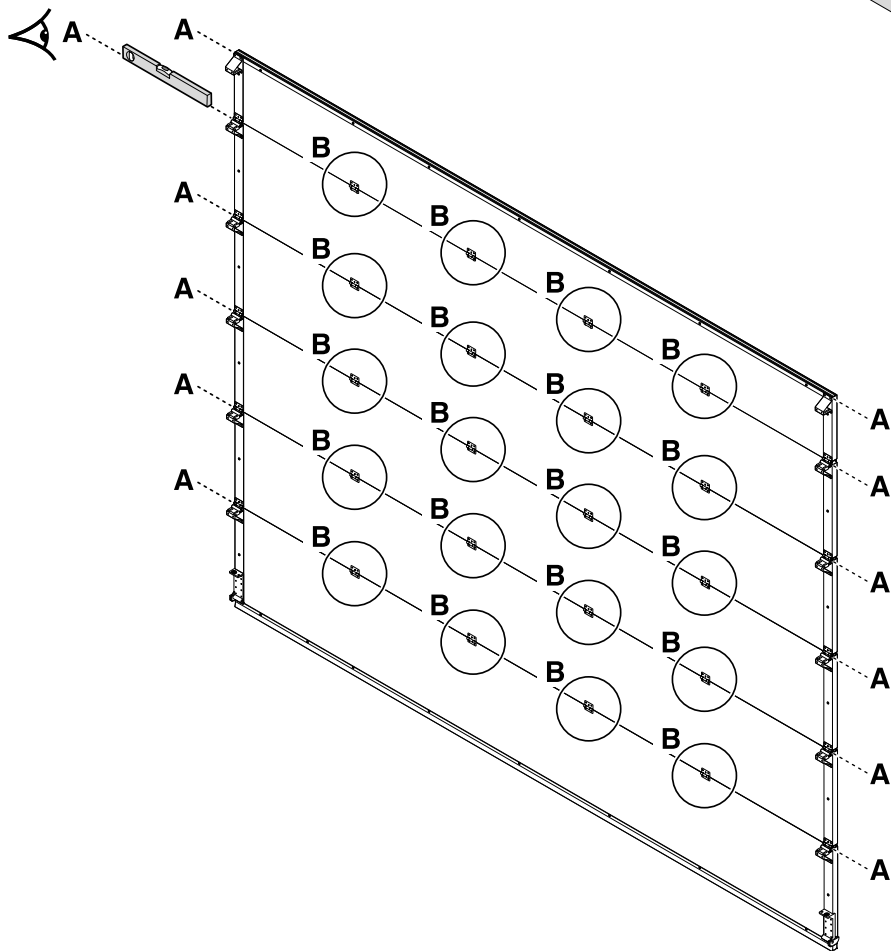

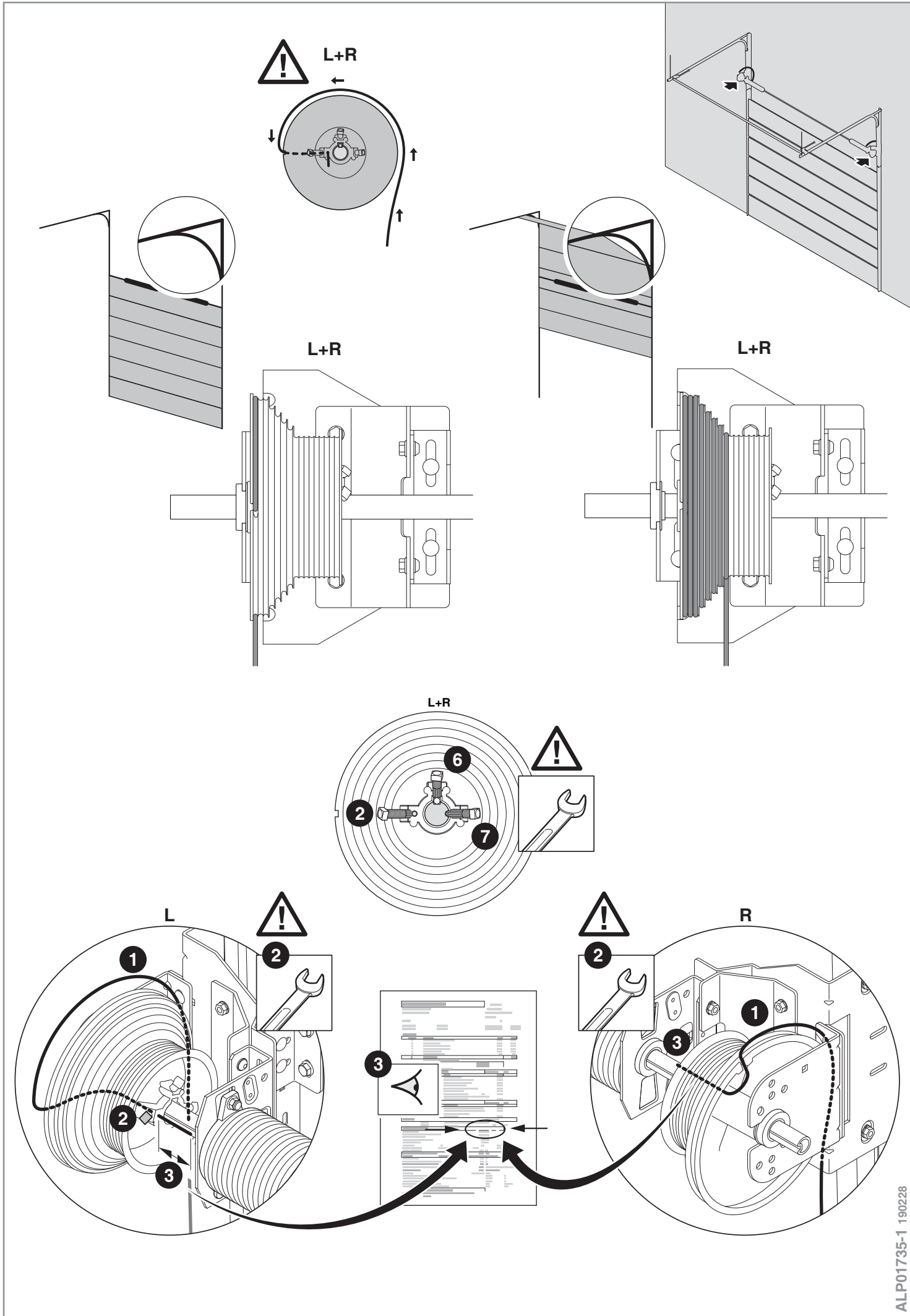

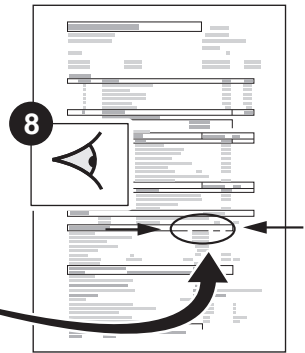
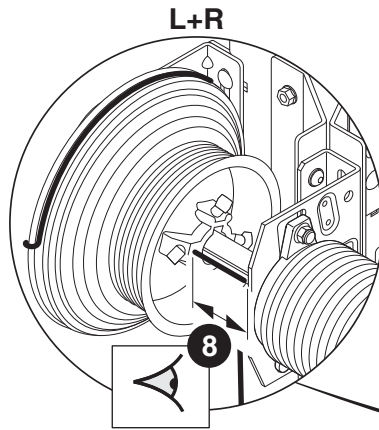
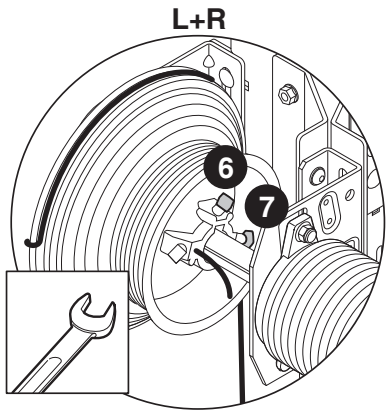
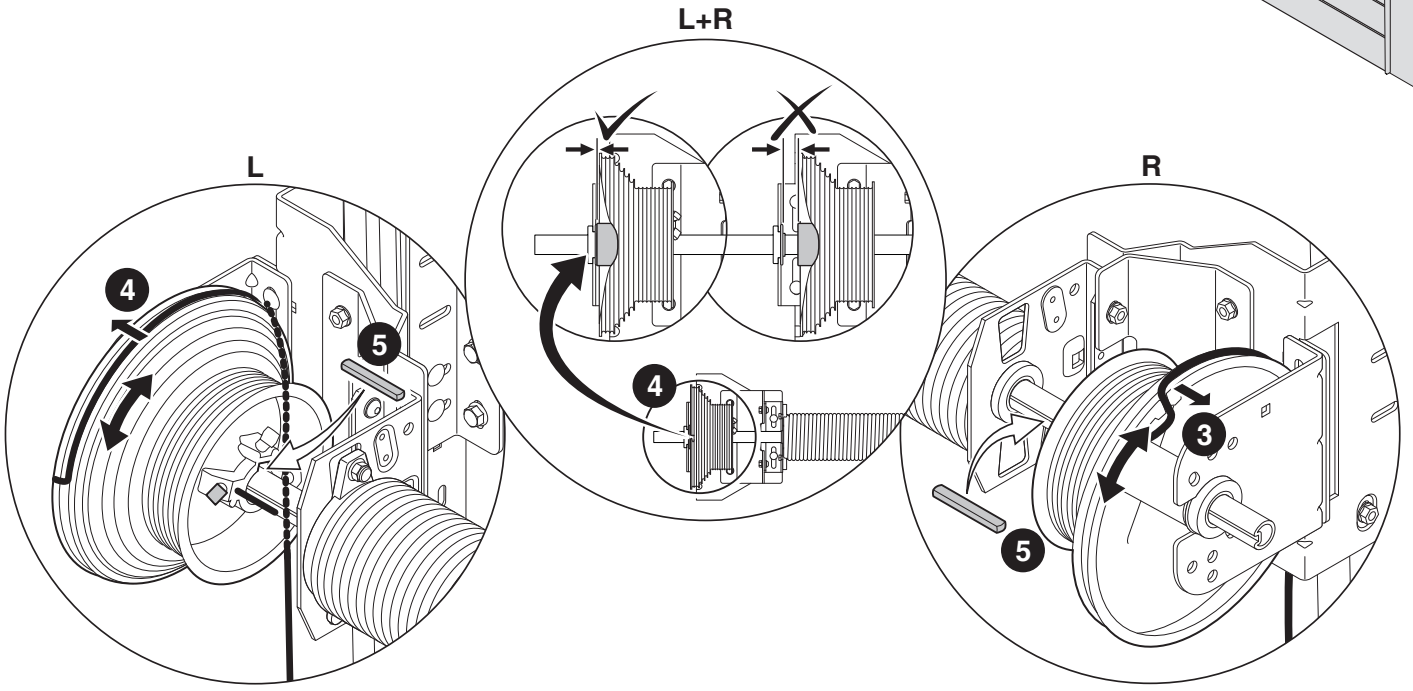
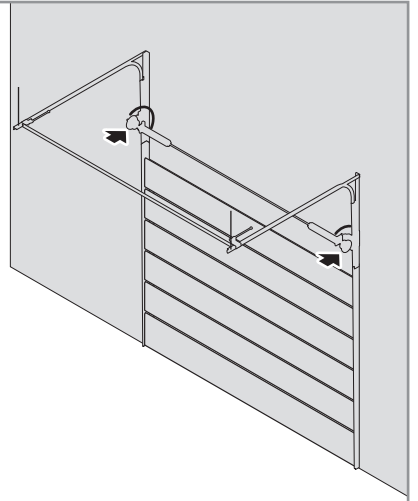

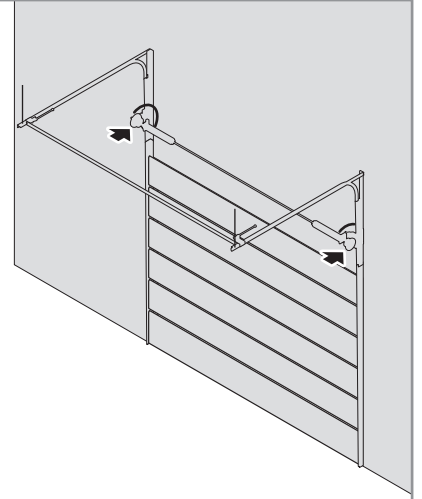
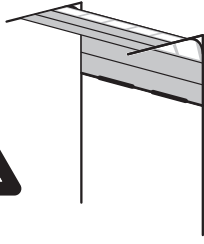

L+R

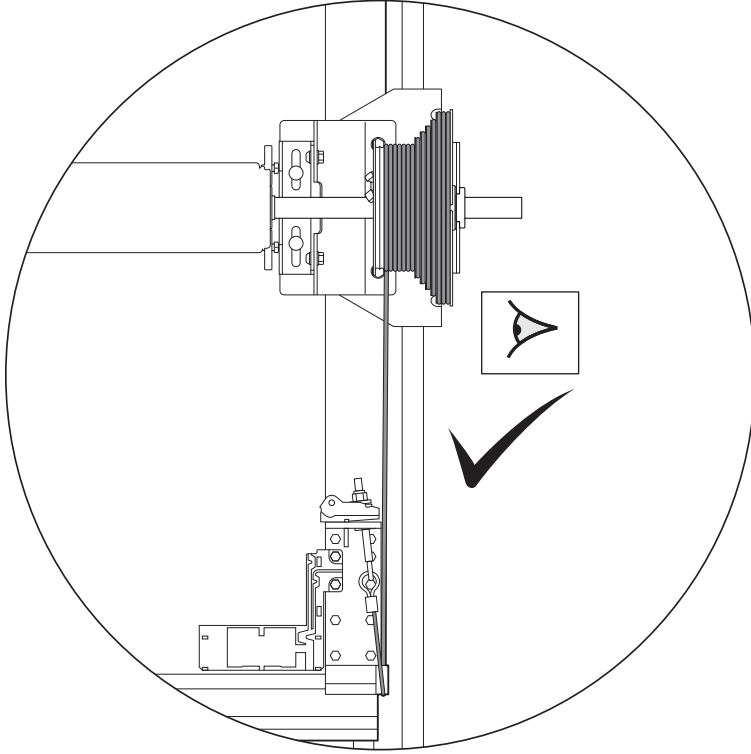

L+R

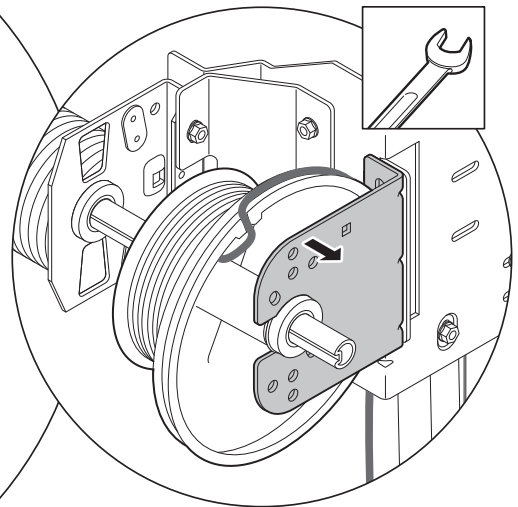
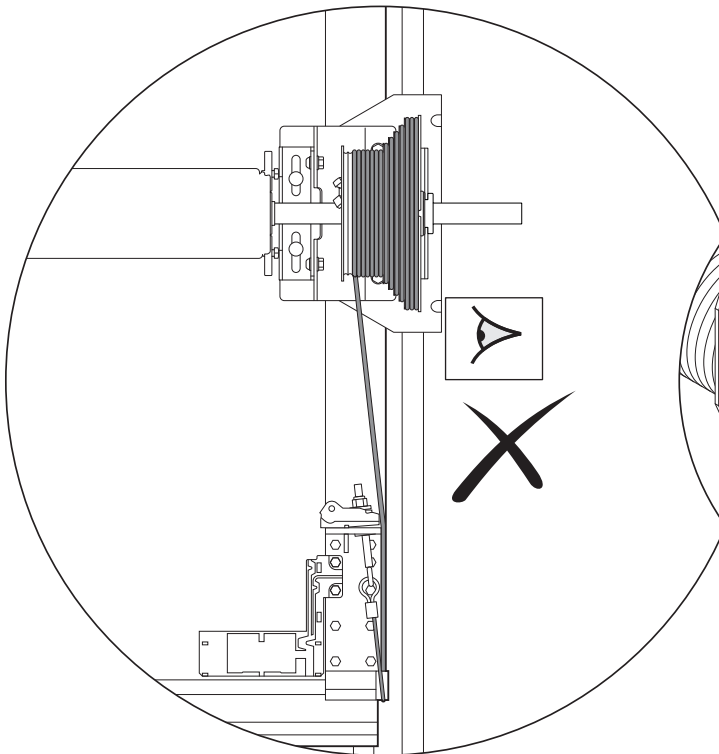

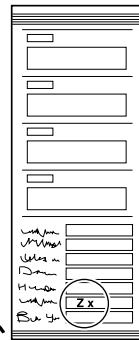
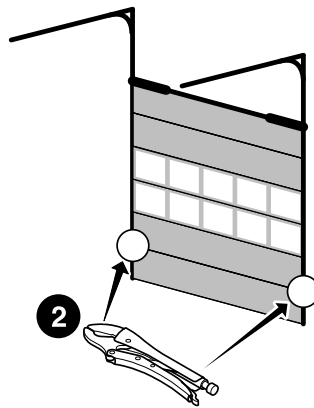
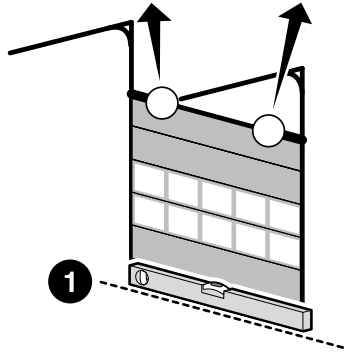
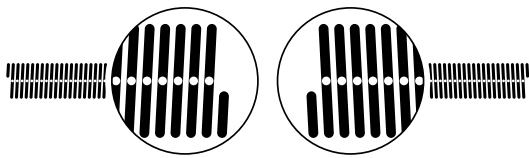

Z x 360°

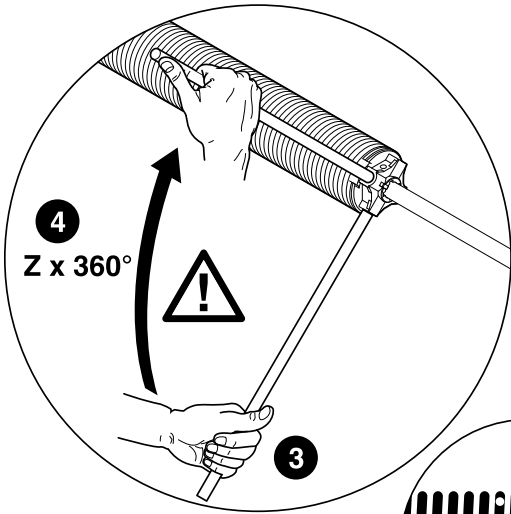
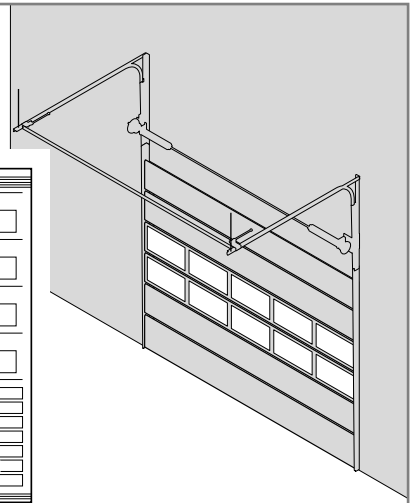

Z x 360°

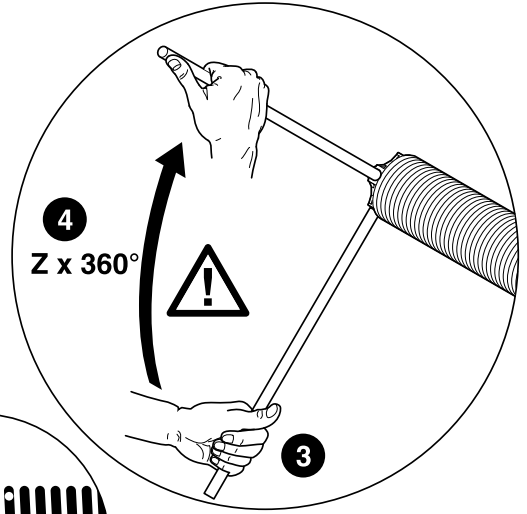

Z x 360°

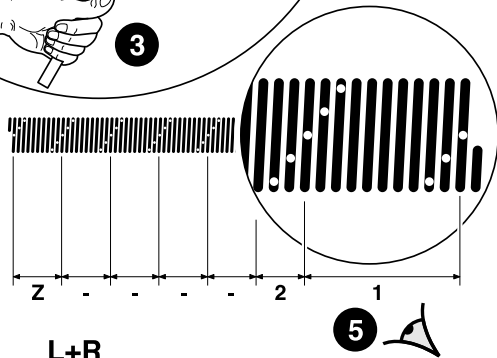

L+R

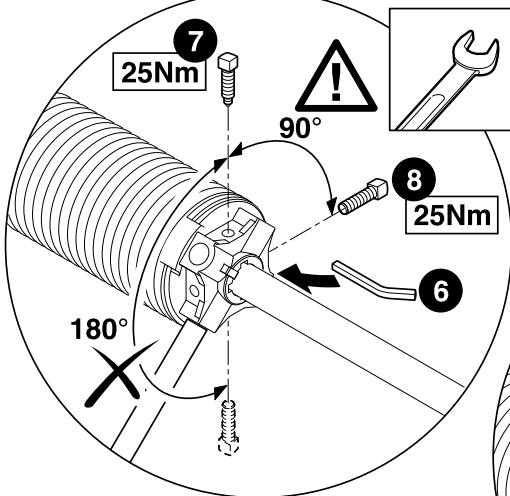
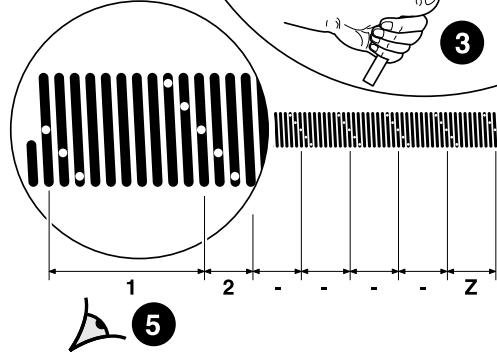

25Nm



25Nm

180°

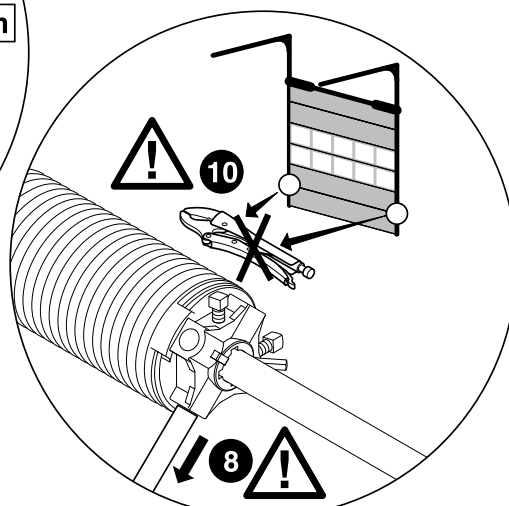

8

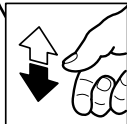
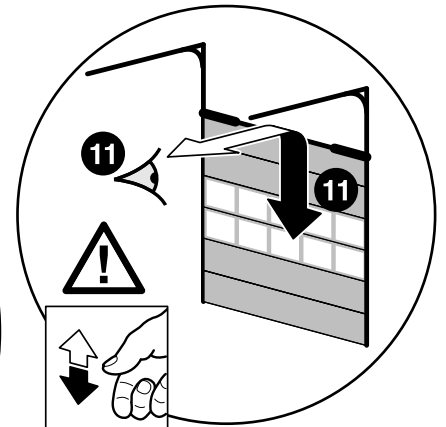

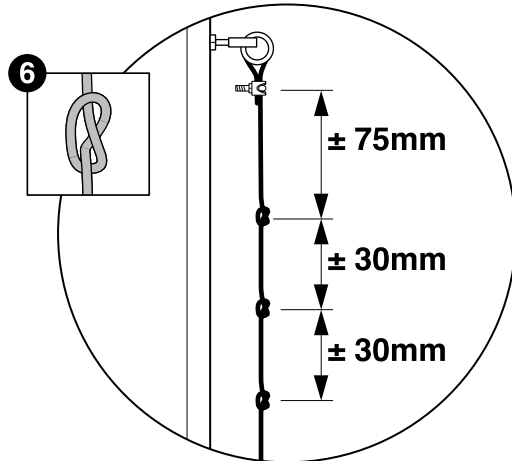
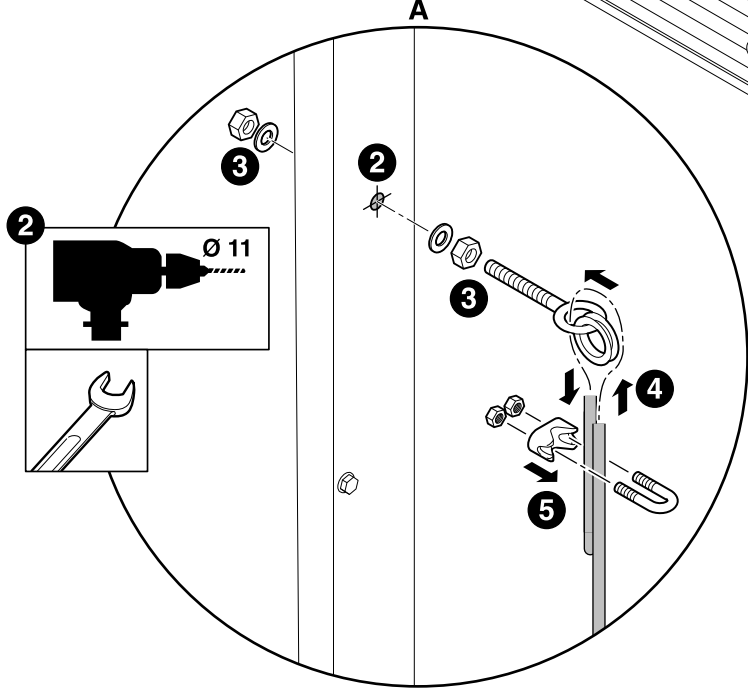
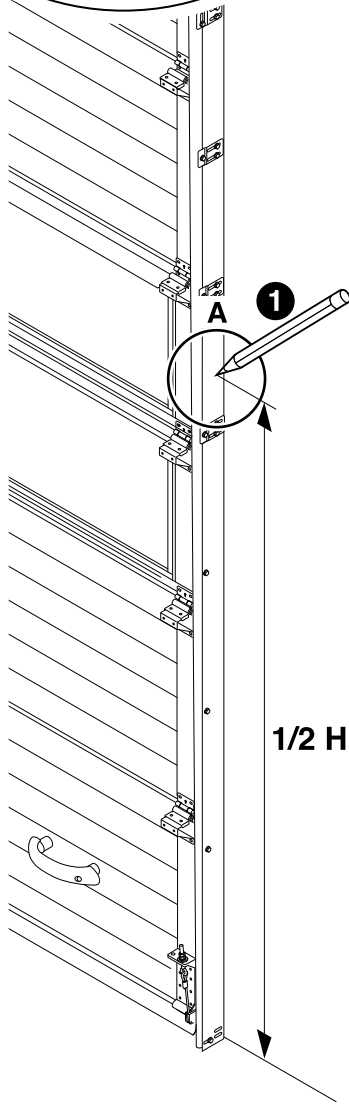
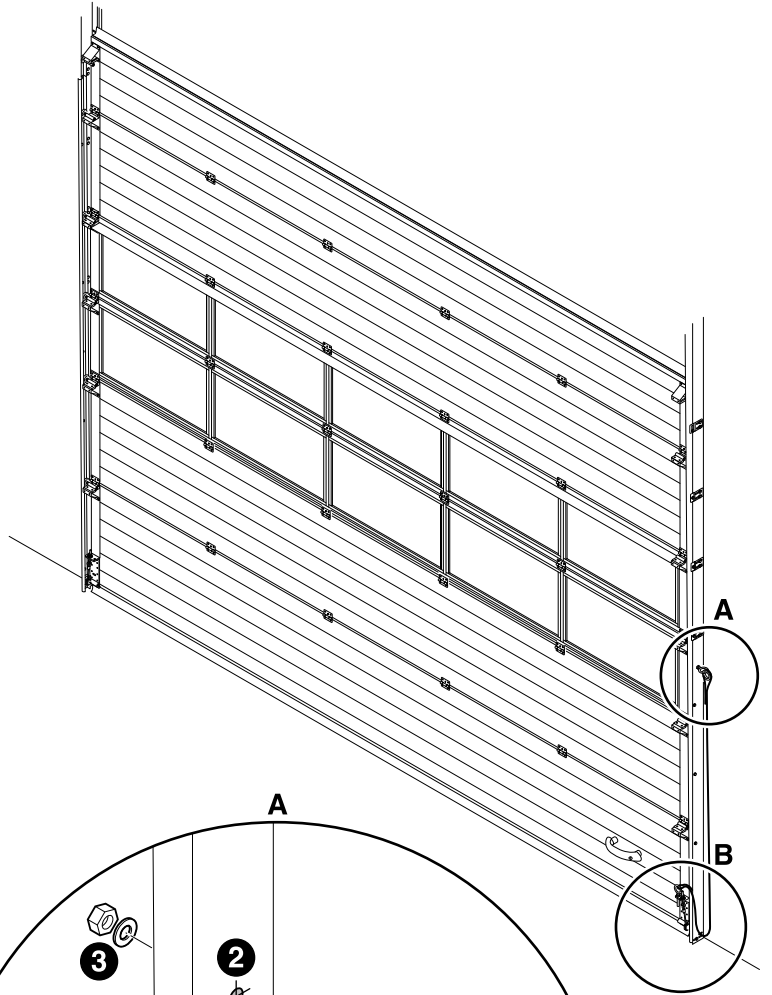
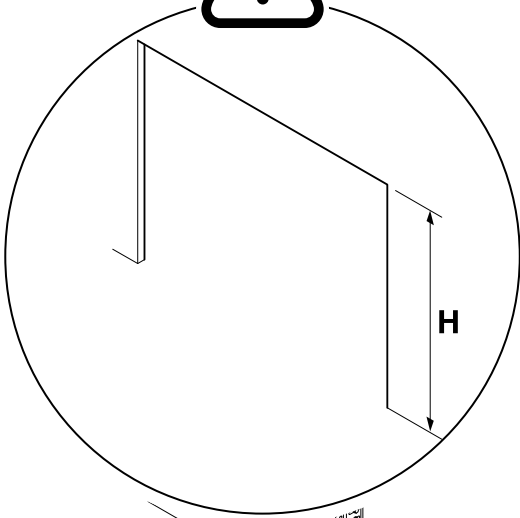
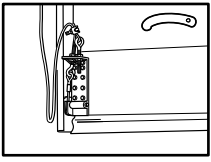

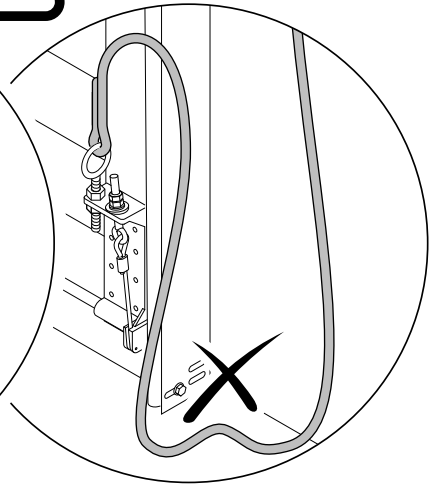
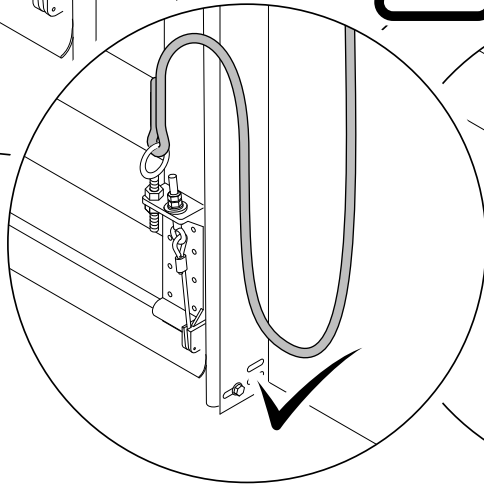
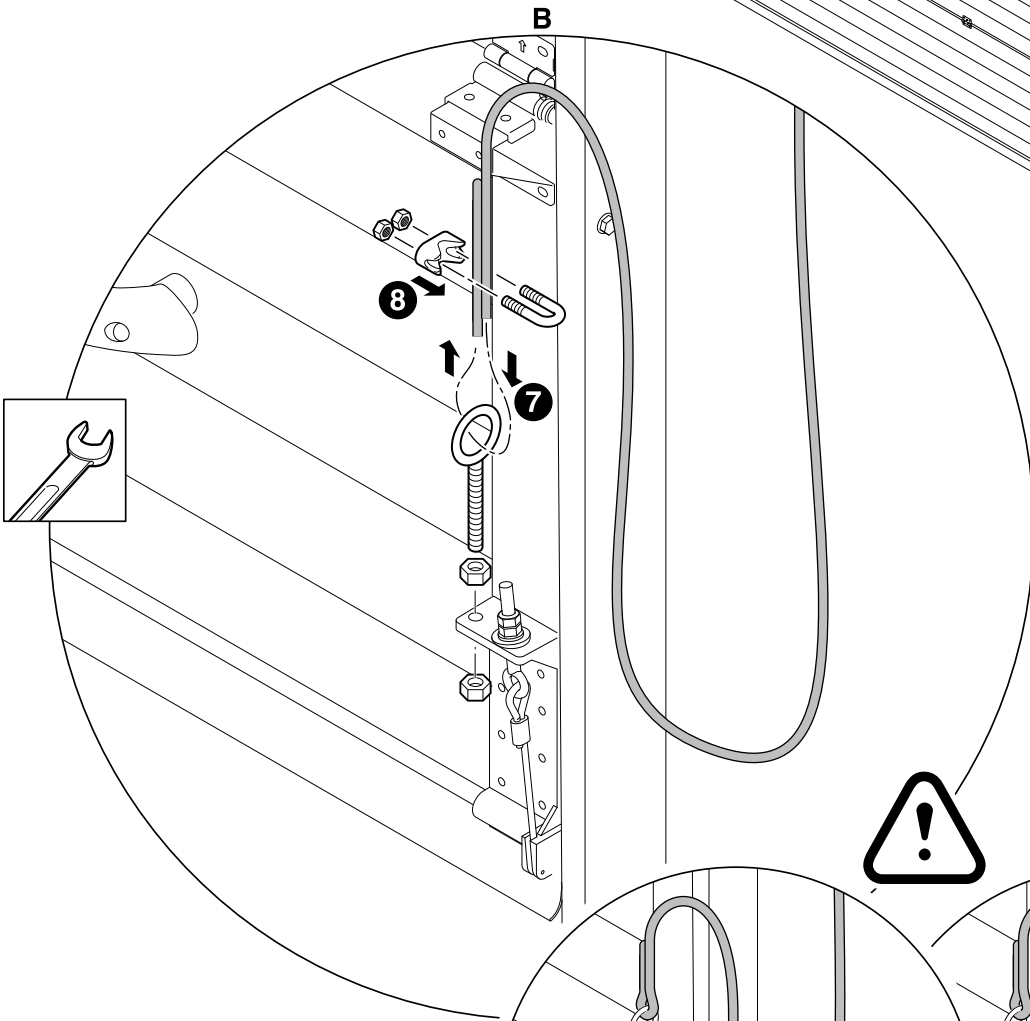
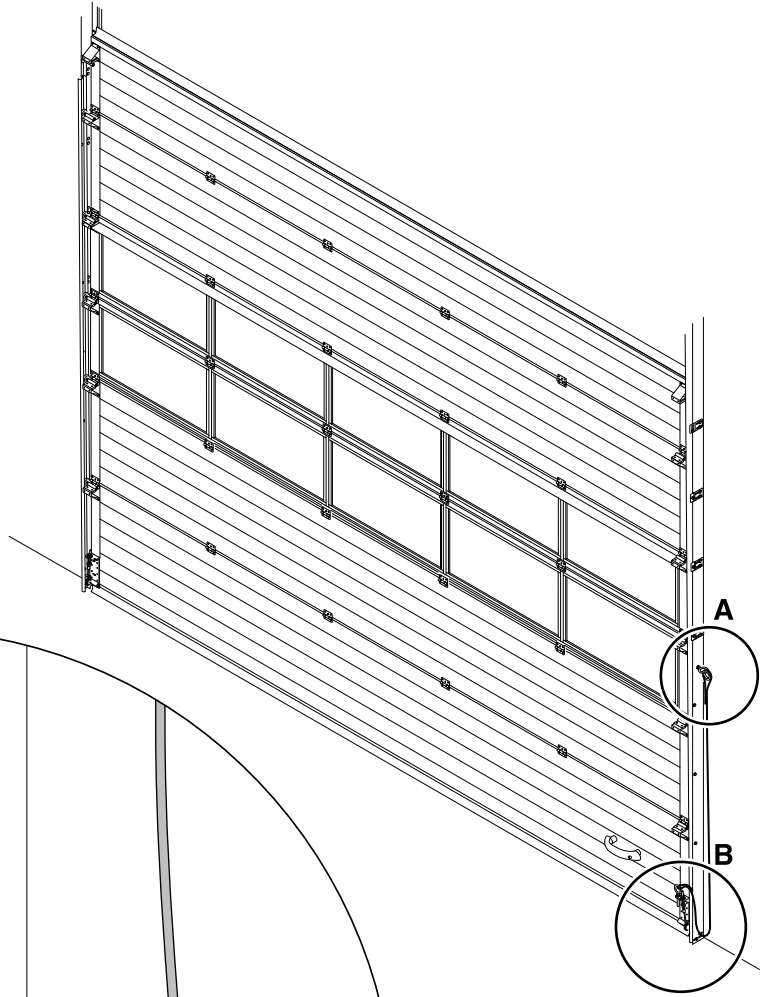
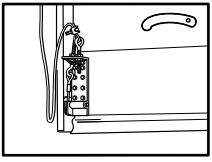

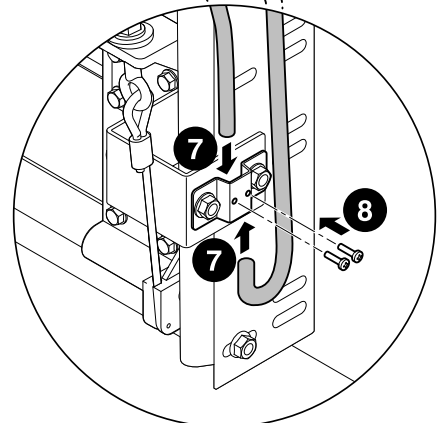
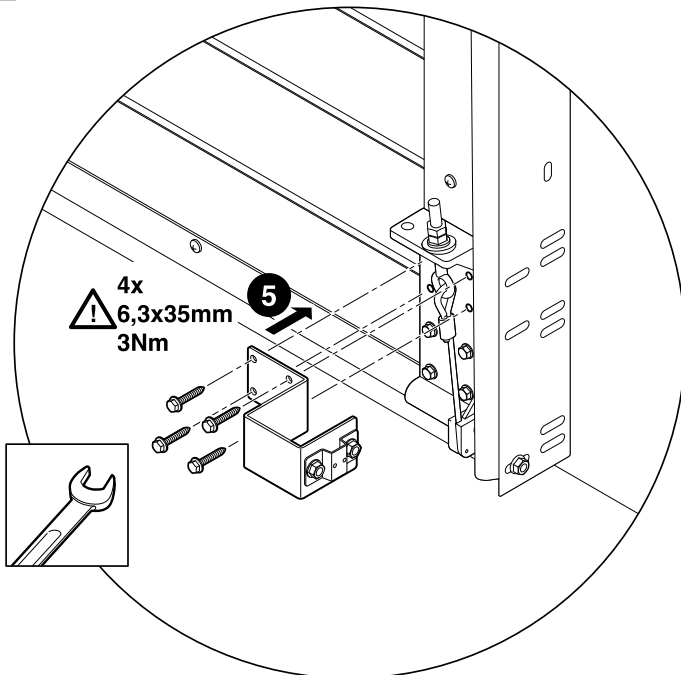
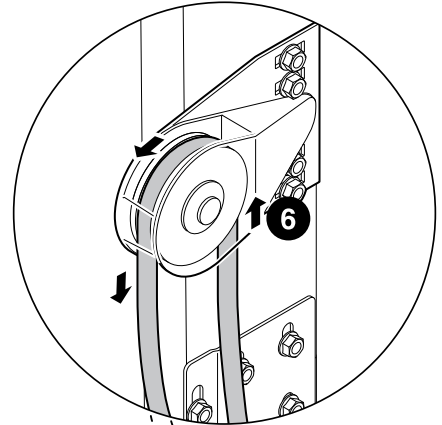
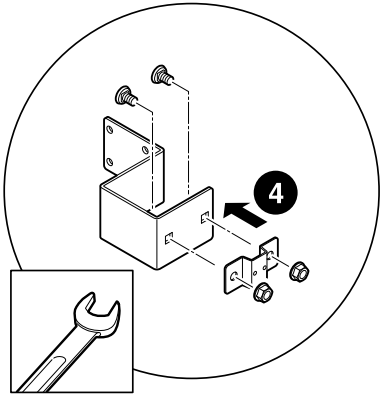
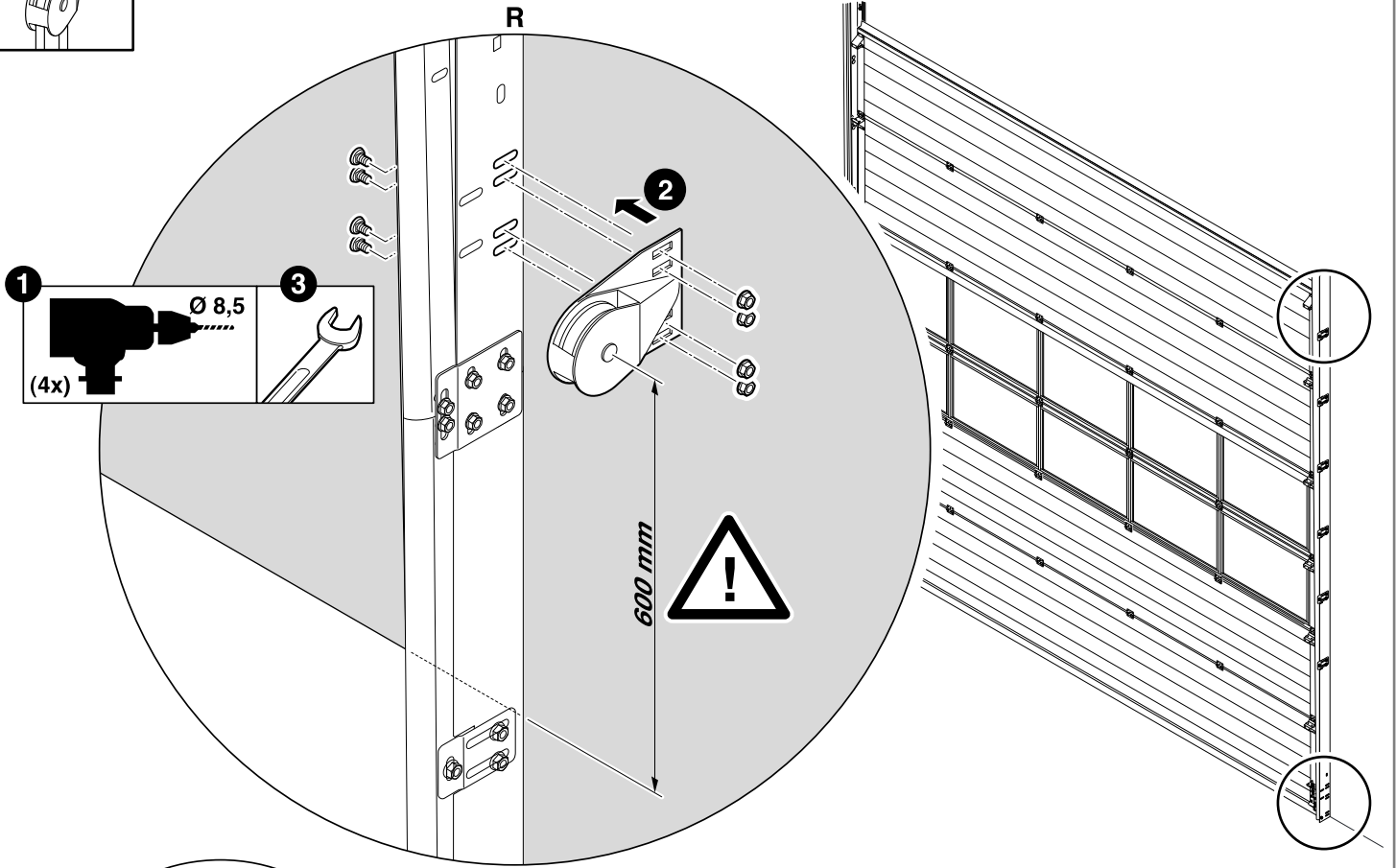
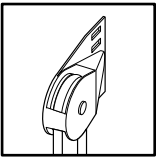

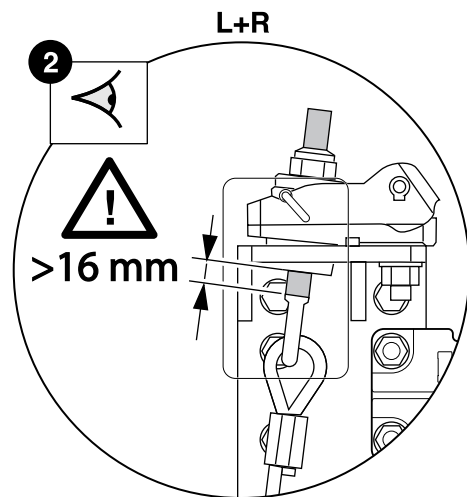
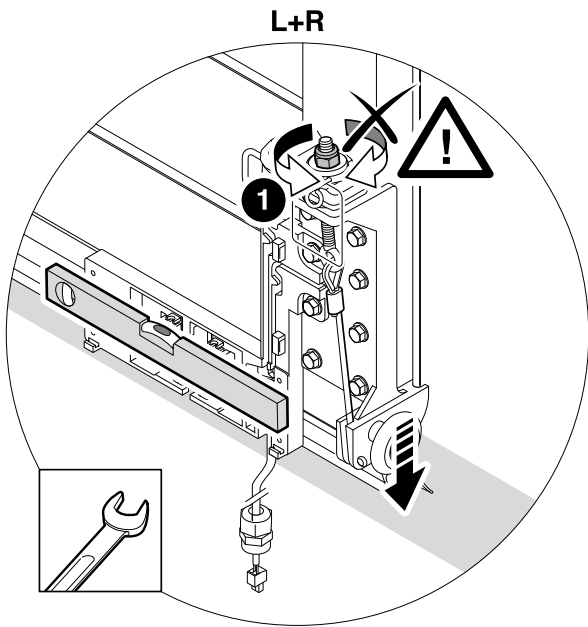
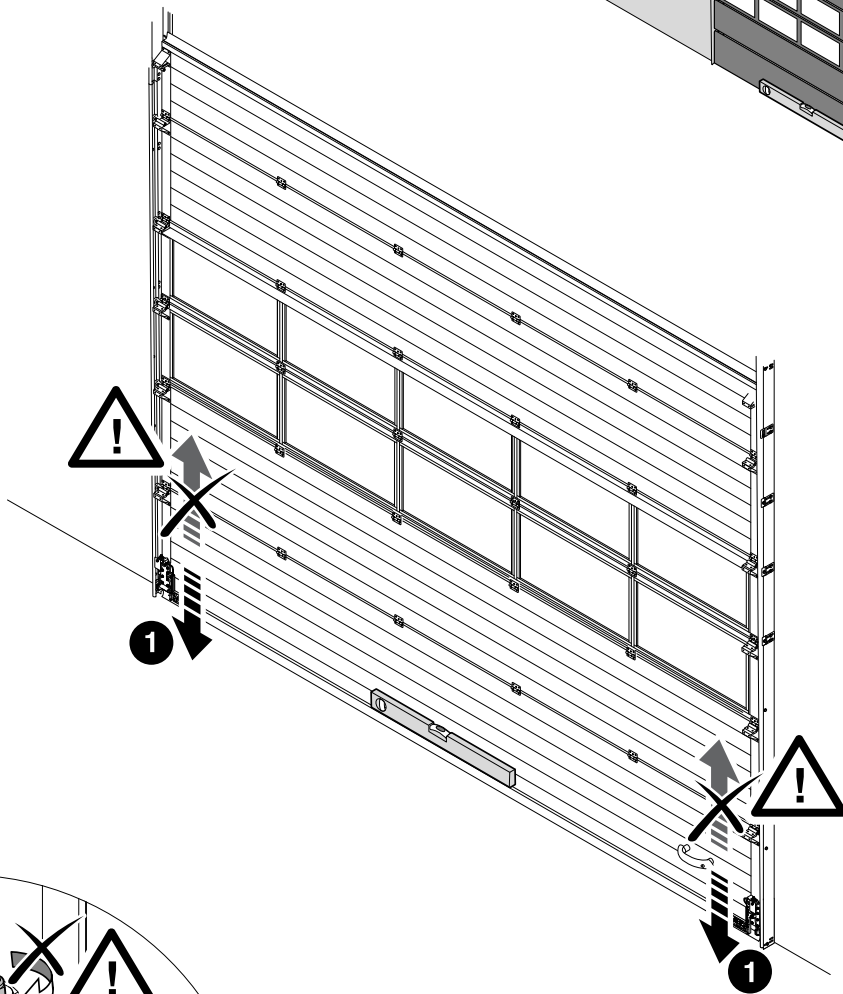
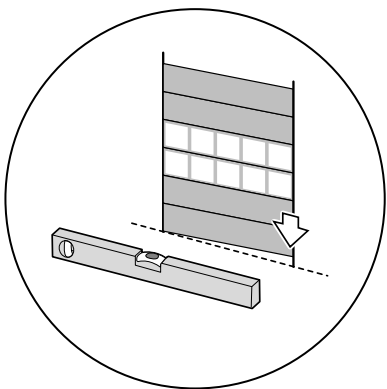
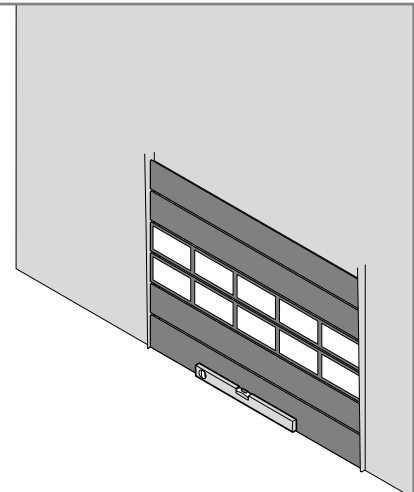
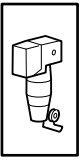

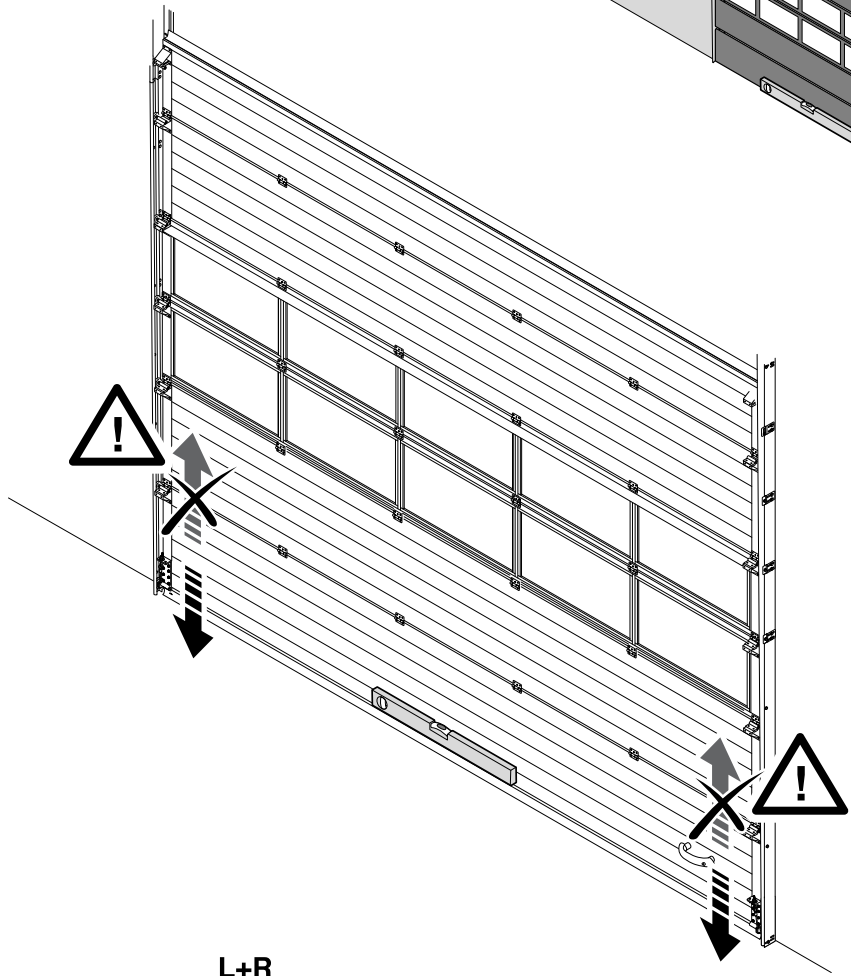
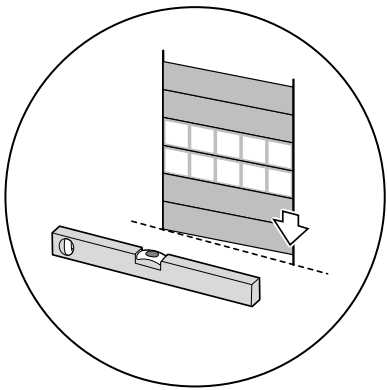
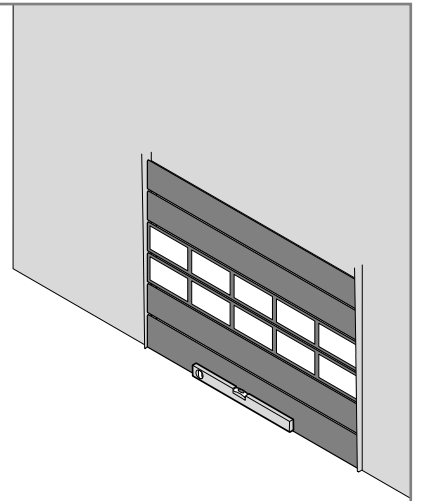
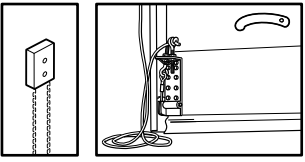

L+R

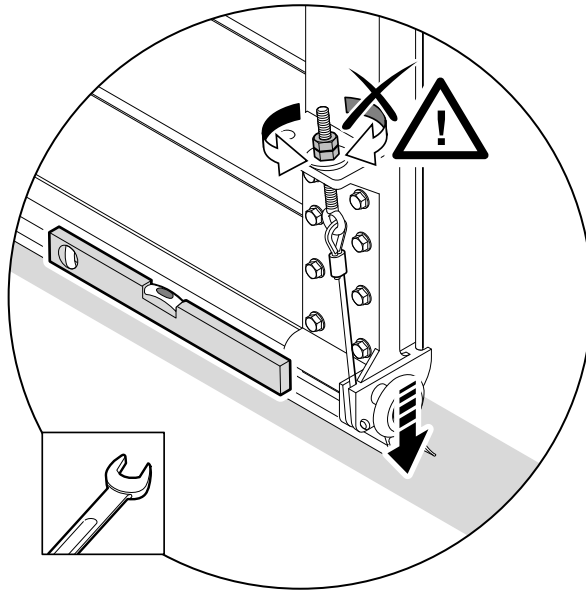

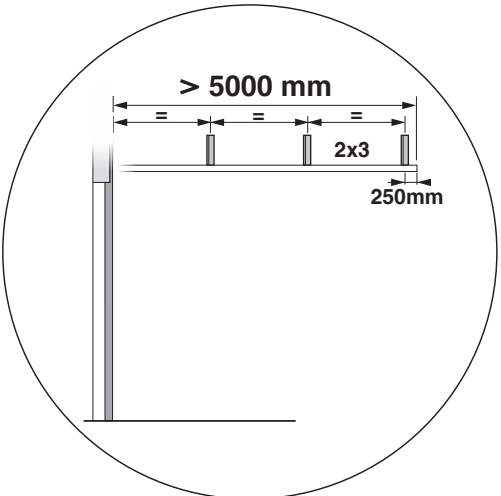
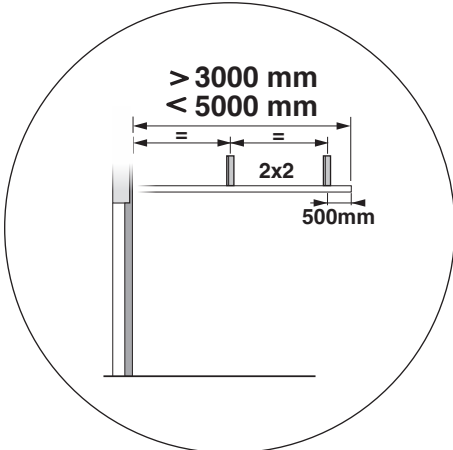
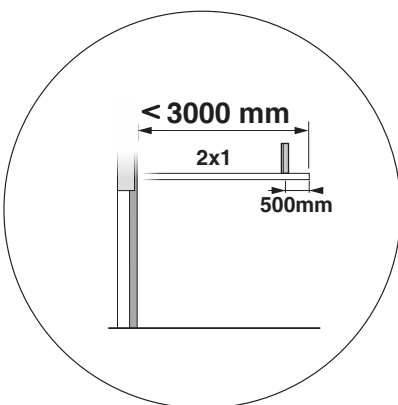
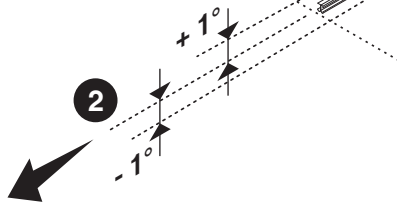
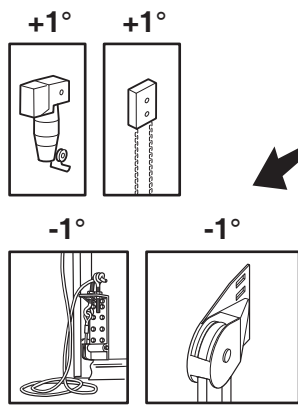
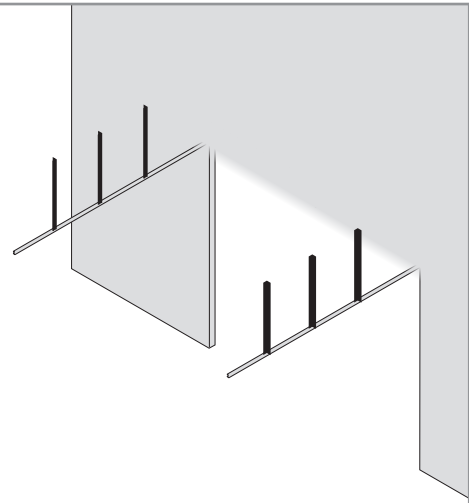
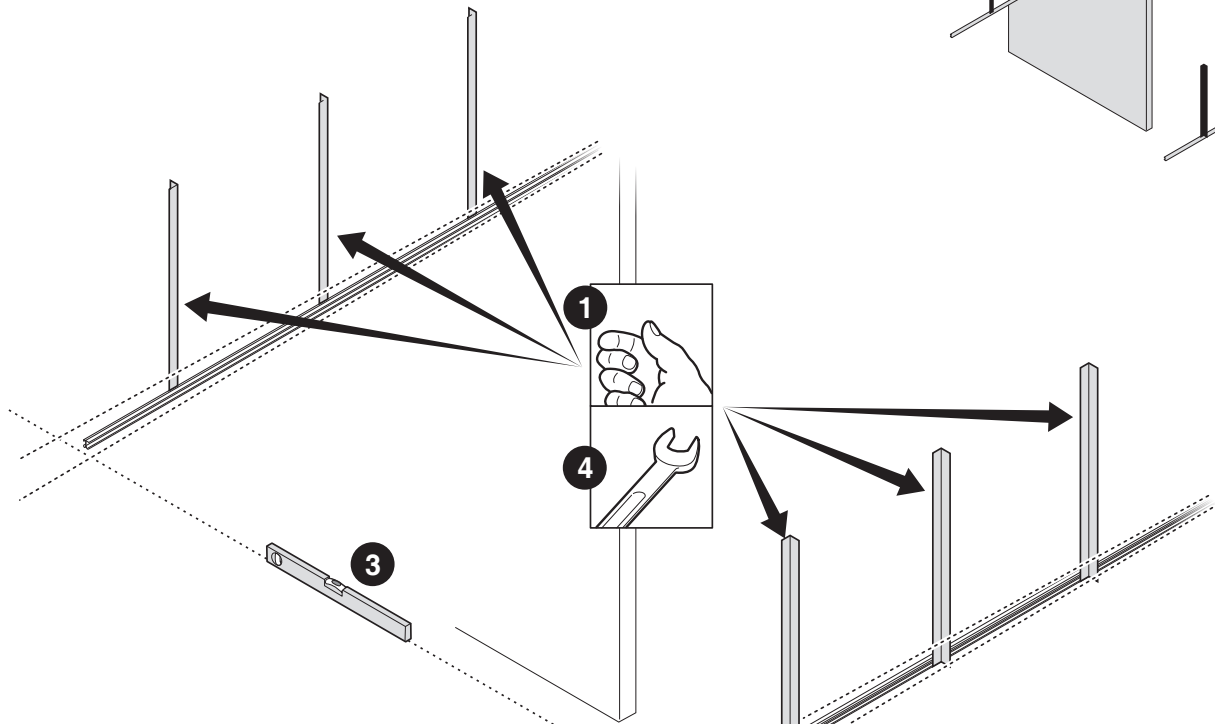
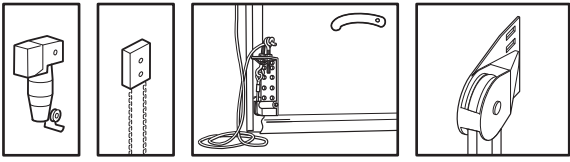

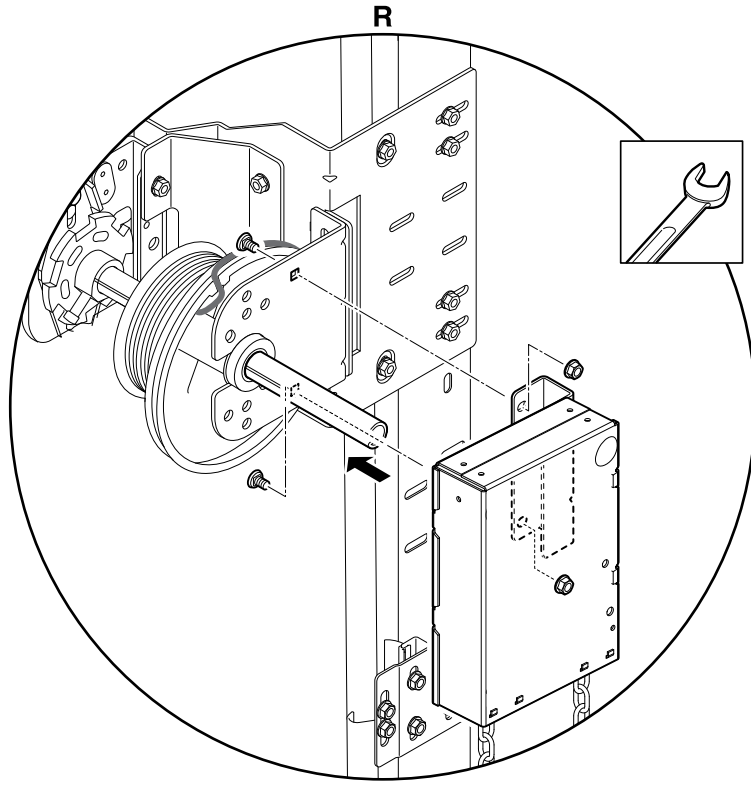
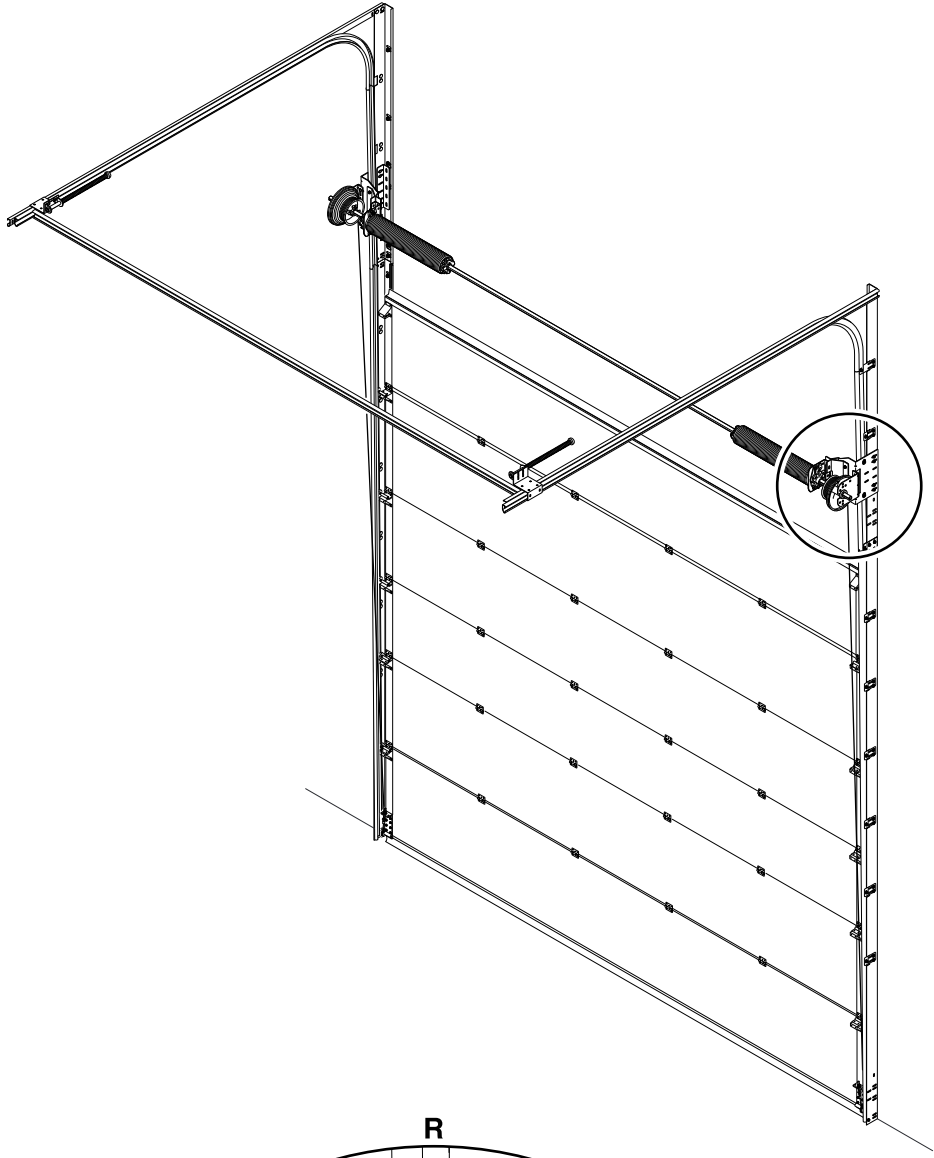
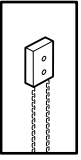

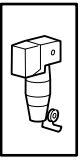

1

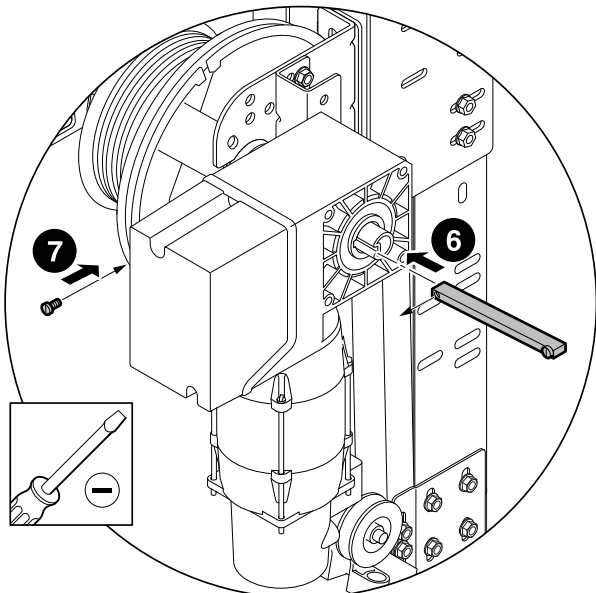
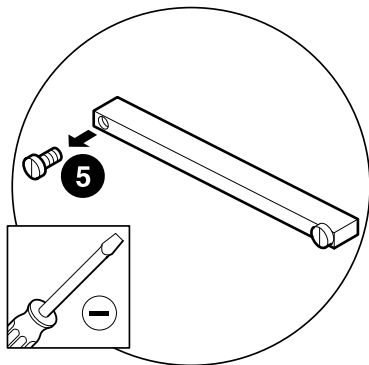
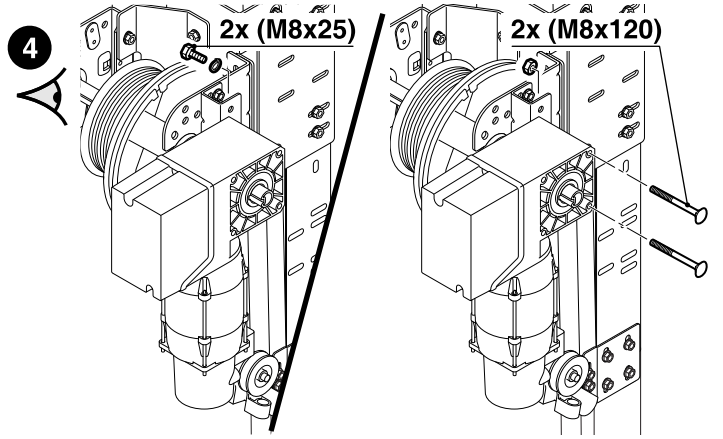
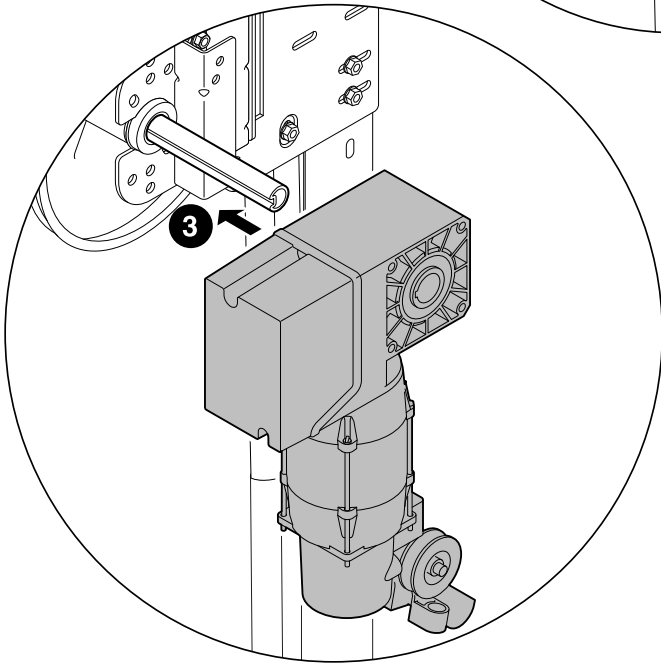
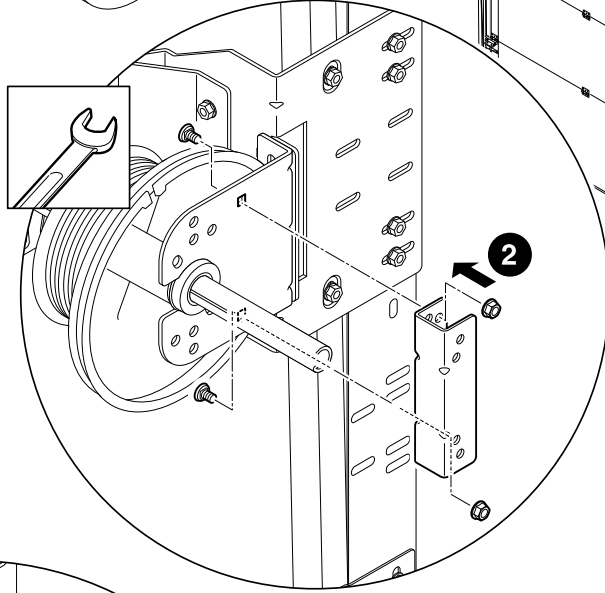
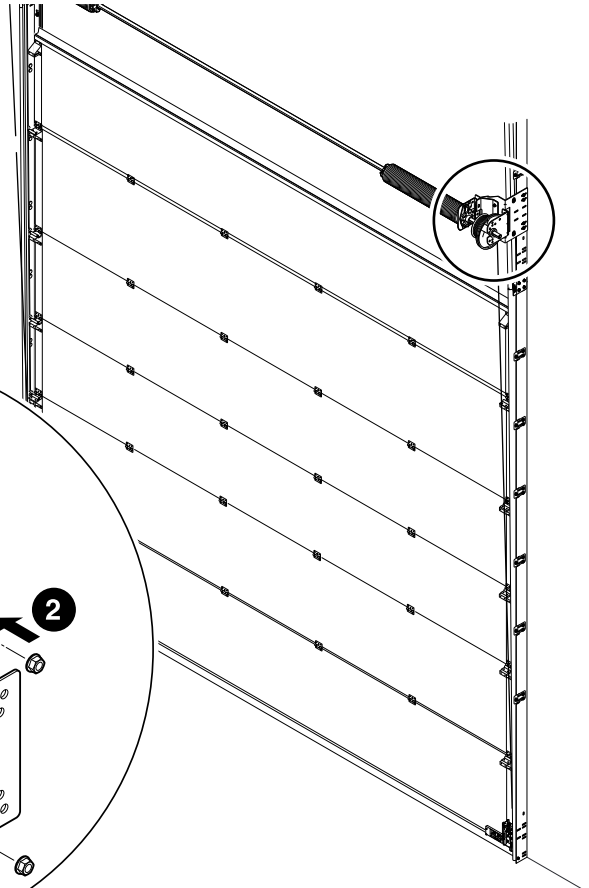
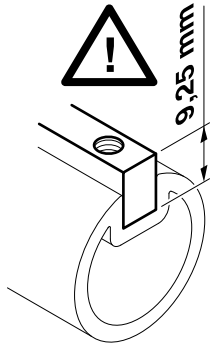
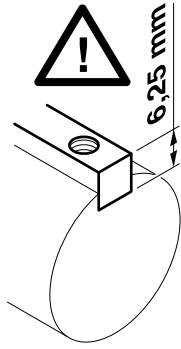

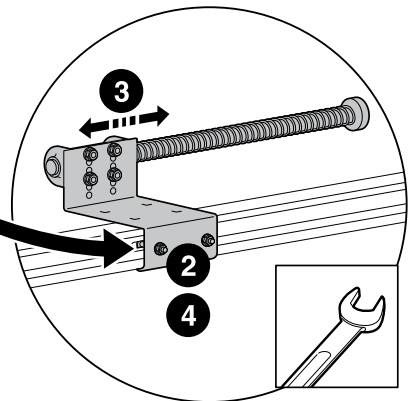
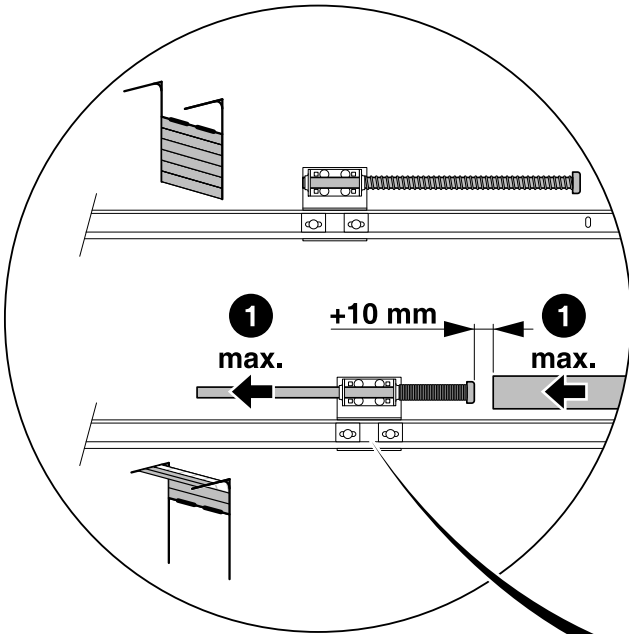
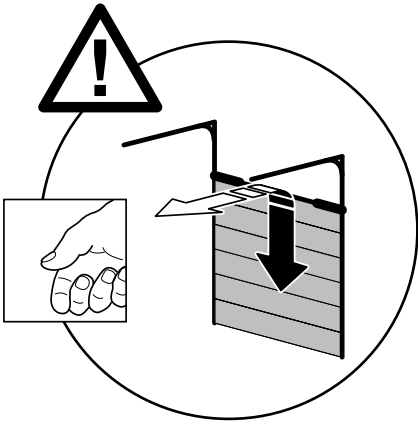
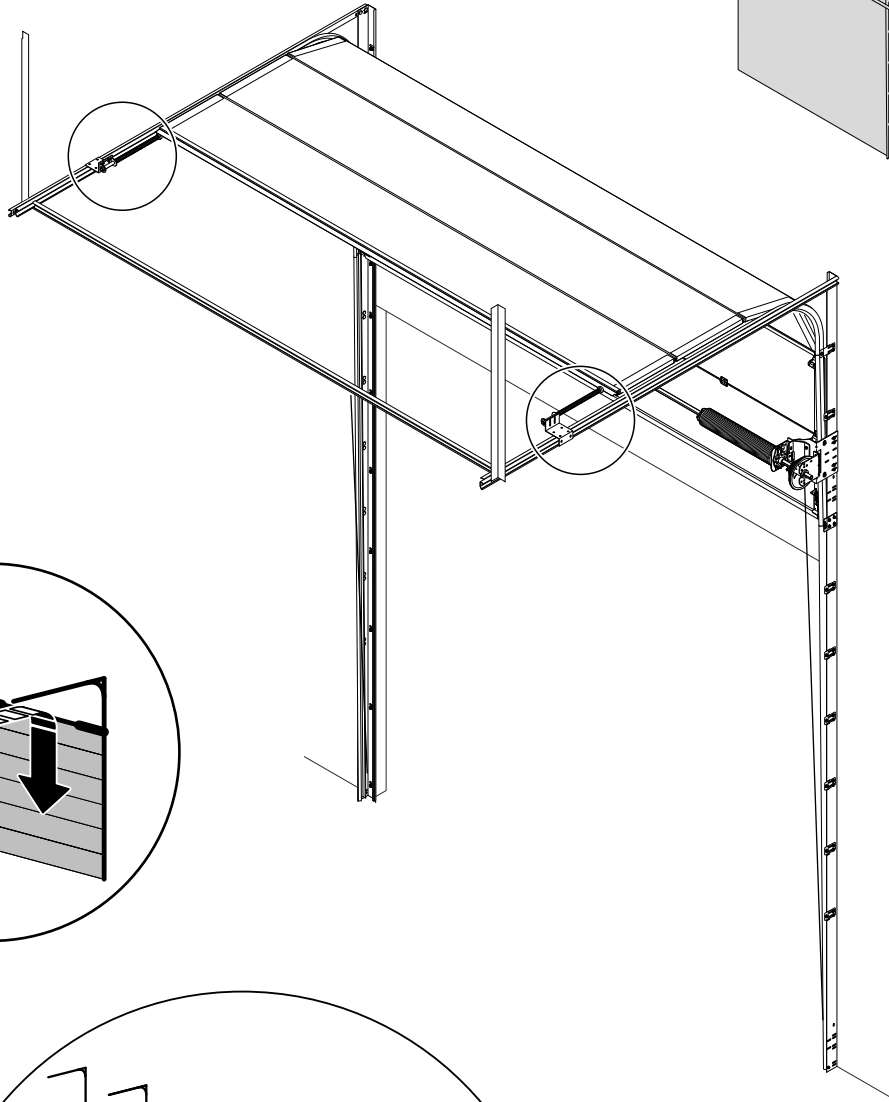
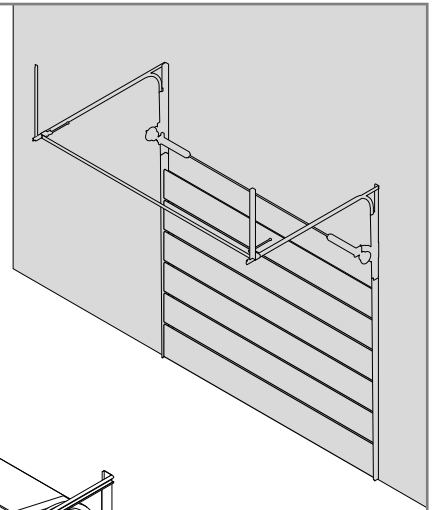
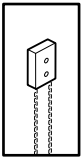

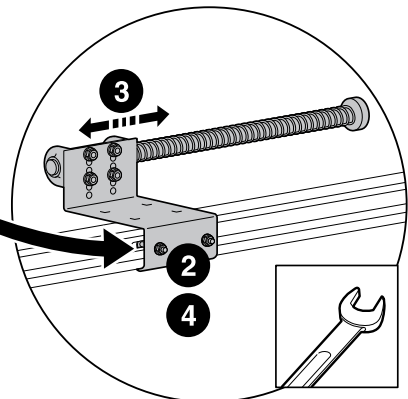
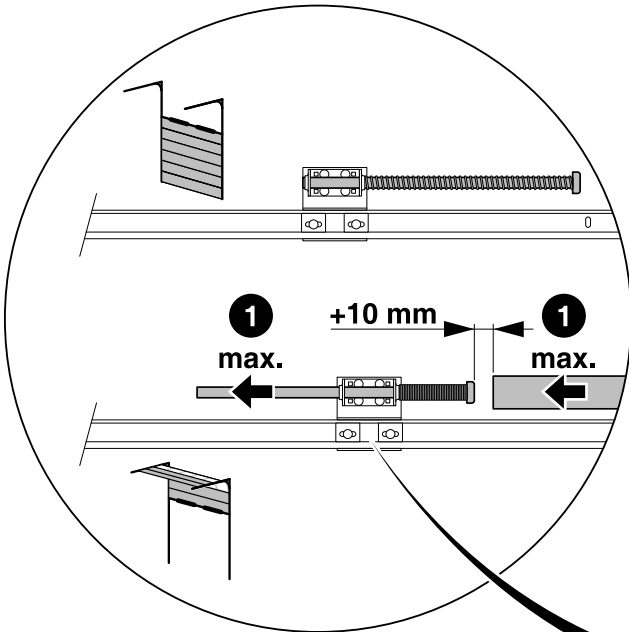
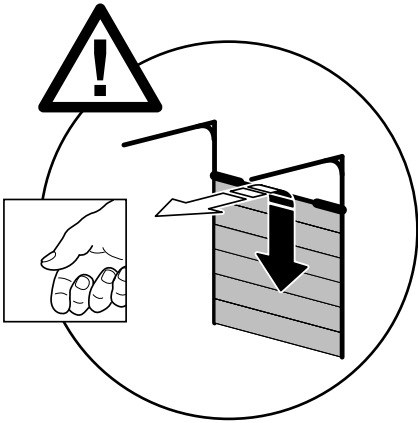
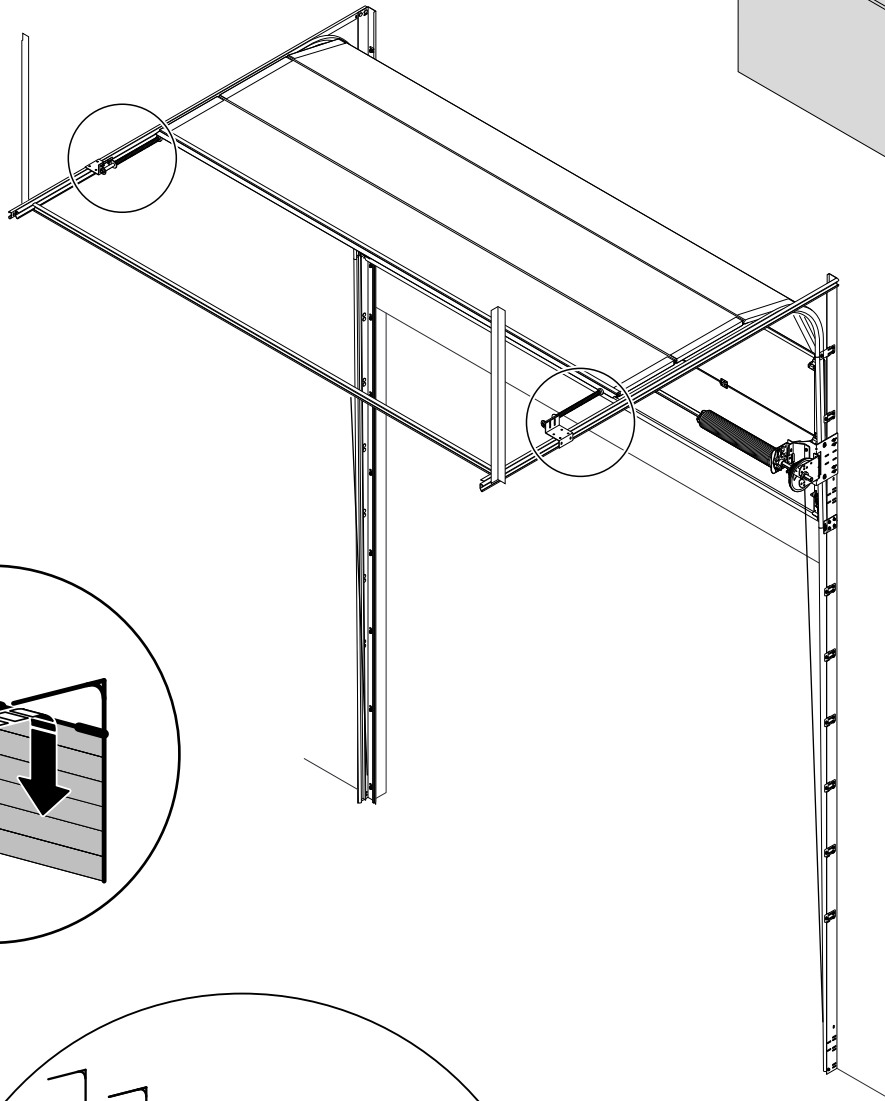
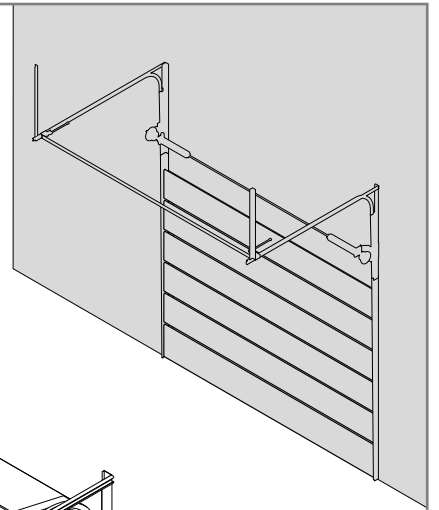
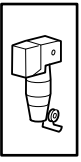

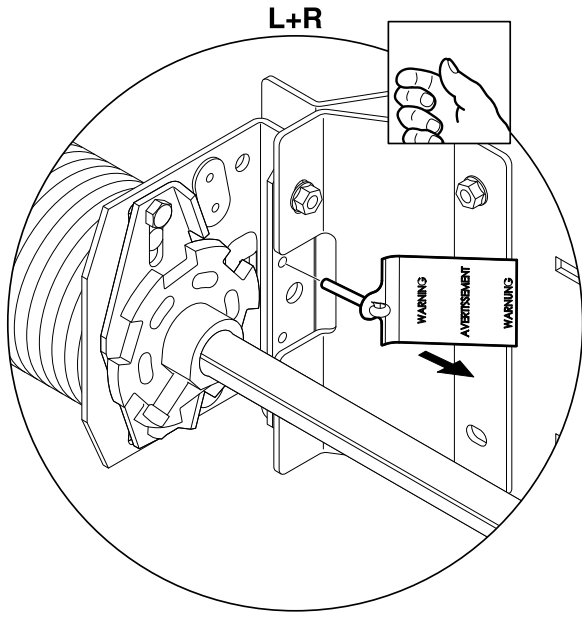
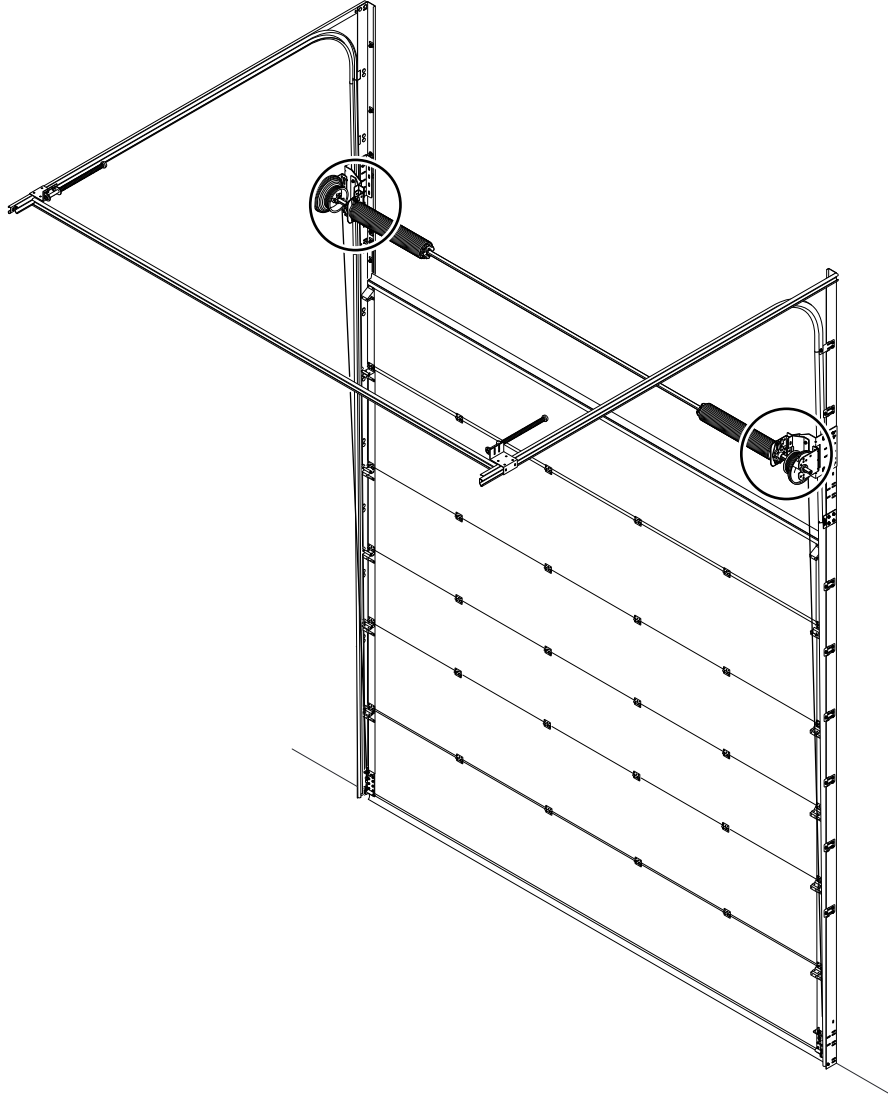
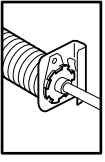

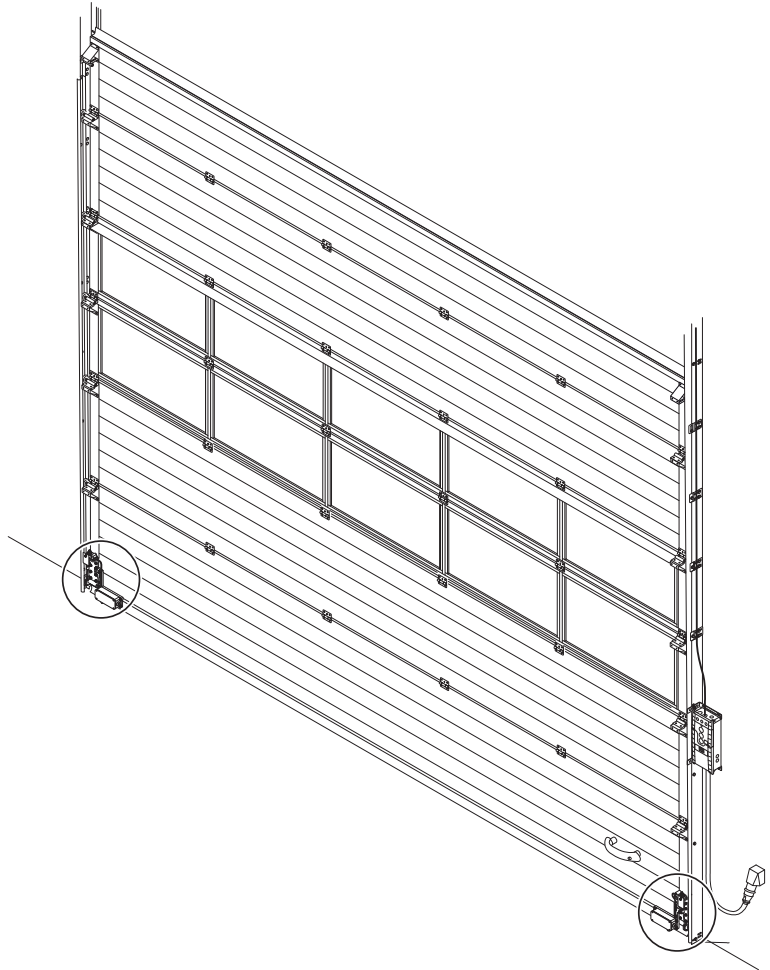
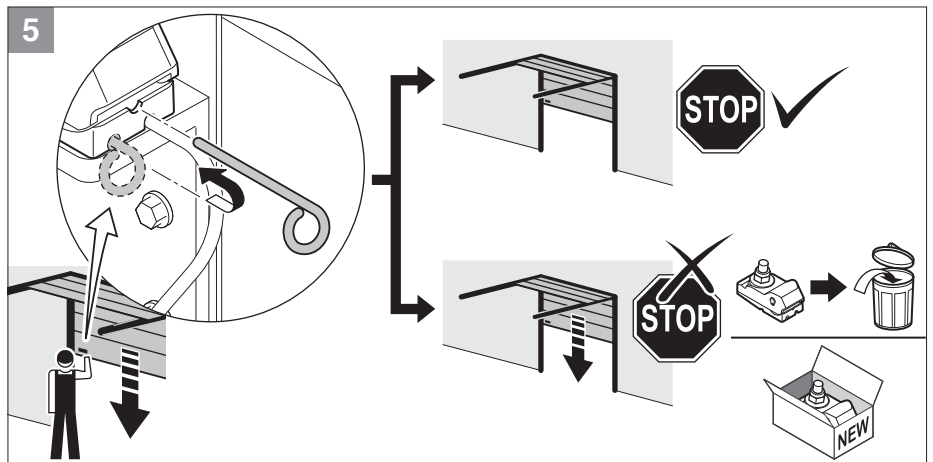
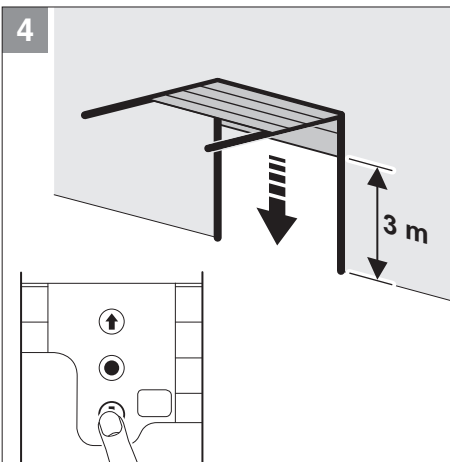
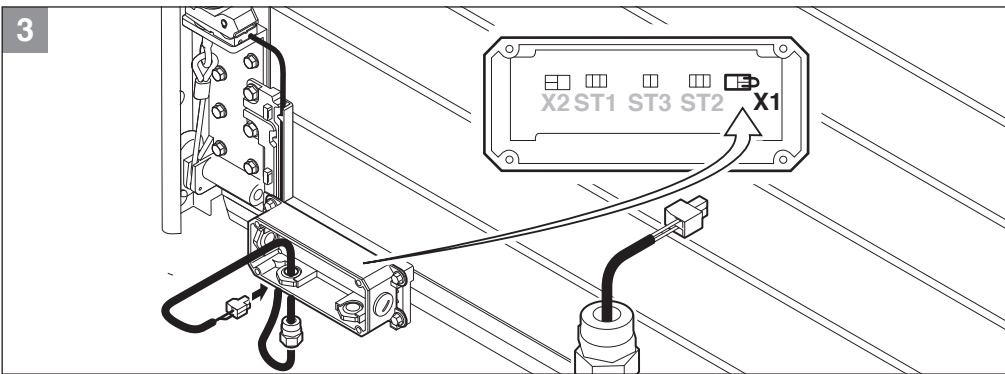
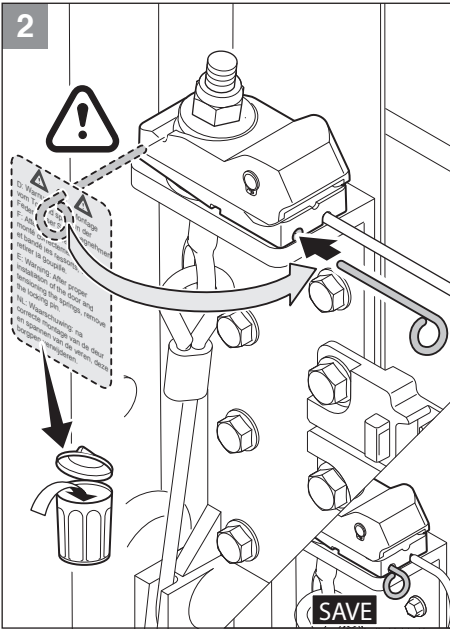
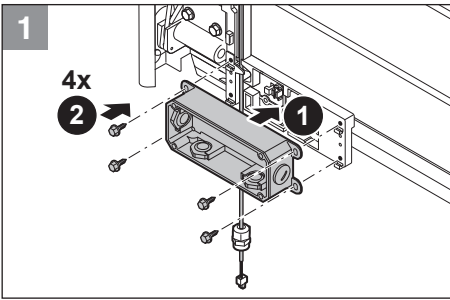

© Copyright Alpha deuren International b.v.

This manual was prepared and issued by Alpha deuren International B.V. Netherlands. It is supplied to approved agents of Alpha deuren International B.V.

All rights are reserved. The information in this document is the property of Alpha deuren International B.V., the Netherlands.

Disclosure of this information or any part of it to third parties is prohibited, except with prior and express written permission of Alpha deuren International B.V., the Netherlands.

Alpha deuren International b.v., Pittelderstraat 10, 6942 GJ Didam, The Netherlands, www.alpha-deuren.nl